

PUBLIC UTILITY DISTRICT NO. 1 OF SKAGIT COUNTY
BOARD OF COMMISSIONERS

AGENDA
MAY 28, 2024
4:30 p.m.

The public is invited to attend in person or via Zoom.

Join the meeting via Zoom: <https://skagitpud.zoom.us/j/82082590753?pwd=ZkUrVGE4T2xXK3NUV1ZRK2pxUDlxdz09>

Meeting ID: 820 8259 0753

Passcode: 009457

Or dial: 1-253-215-8782

Please turn your audio and video off during the meeting. Use the "Raise Hand" feature if you would like to speak during Audience Comments.

If you have a question or comment for the Board, please submit it by 5 p.m. the Monday prior to the meeting by calling (360) 848-4460 or send an email to pud@skagitpud.org

PLEDGE OF ALLEGIANCE

CONSENT AGENDA

1. Approval of Agenda 5/28/24
2. Approval of Minutes 5/14/24 Regular Meeting
3. Ratification of Voucher 5/14/24
4. [Peterson Road Plat Project Acceptance](#)
5. [Mount Vernon Library Project Acceptance](#)
6. [Information Technology \(IT\) Policy Adoption](#)

AUDIENCE COMMENTS

OLD BUSINESS

7. General Manager's Report
8. IT Department Update
9. [Mount Vernon High School Energy Recovery Demonstration Project - Action](#)
10. [Financial Hardship Assistance Application - Discussion](#)
11. [Public Records Act Resolution, Policy, and AP&P - Action](#)

NEW BUSINESS

12. [SkagitNet Resolution No. 24-10, Concerning Banking and Amending Operating Agreement - Action](#)
13. [Pipeline Relocation Projects on SR-20 at Olson Creek and SR-9 North of Kalloch Road, Change Order 01 - Action](#)
14. Draft Water System Plan Presentation - *Discussion*

INFORMATION

15. Judy Reservoir Data Report
16. Recent News Article

COMMISSIONER COMMENTS

ADJOURNMENT

MINUTES OF THE REGULAR MEETING OF THE COMMISSION
PUBLIC UTILITY DISTRICT NO. 1 OF SKAGIT COUNTY, WASHINGTON

May 14, 2024

The regular meeting of the Commission of Public Utility District No. 1 was held in the Aqua Room of the utility located at 1415 Freeway Drive, Mount Vernon, Washington.

The meeting was called to order at 4:30 p.m. Commissioners Joe Lindquist, president; Andrew Miller, vice president; and Corrin Hamburg, secretary, were in attendance.

In attendance were George Sidhu, Shannon Patiño, Nick Semrau, Mike Fox, Jay Sedivy, Pete Gilbert, Brian Henshaw, Krista Lewis, Kevin Tate, Alistair Boudreaux, Mark Handzlik, Mark Semrau

Participating remotely: Courtney Shilling

Commissioner Lindquist led the Pledge of Allegiance.

CONSENT AGENDA

Commissioner Hamburg moved to approve the Consent Agenda for May 14, 2024, as presented.

1. Approval of Agenda 5/14/24
2. Approval of Minutes 4/23/24 Regular Meeting
3. Ratification of Voucher 4/30/2024 No. 3133 (\$471,608.01)
Accounts Payable Voucher No. 29065 – 29104 (\$440,224.90)
Electronic Funds Transfer (\$31,383.11)
4. Voucher Approval 5/7/24 No. 3134 (\$2,104,182.6)
Accounts Payable Voucher No. 29105 - 29165 (\$208,463.68)
Electronic Funds Transfer (\$1,661,948.73)
Payroll Electronic Funds Transfers No. 043914 – 043999 (\$233,770.26)

The motion passed unanimously.

AUDIENCE COMMENTS

None

OLD BUSINESS

5. Manager's Report: General Manager Sidhu provided an update on the following:
 - Manager Sidhu presented a PUD update at the Mount Vernon City Council meeting on April 24 and the Sedro-Woolley City Council meeting on May 8.
 - Manager Sidhu met with the city administrator and the mayor of Burlington and was invited to present a PUD update at an upcoming council meeting.
 - The WPUA Water Workshop will be held September 25-27 in Spokane and coincides with the WASWD Fall Conference & Trade Show from September 24-16 in Spokane. WPUA and WASWD will be coordinating to combine sessions and speakers so attendees can attend both conferences.
 - The PUD Top Ops team took first place at the PNWS-AWWA Section Conference and will move on to compete at the national conference in June.
 - The water rights transfer applications are still in the queue with the Department of Ecology and are nearing the end of the 30-day public comment period.
 - A construction progress update on the PUD Campus Replacement Project.
 - Three pumps are running at the Skagit River Diversion (SRD), which is helping Judy Reservoir gain elevation.
 - On May 9, as part of AWWA's Drinking Water Week, the PUD hosted community tours and were attended by 45 people.
 - Information item #13: AP&P #2047 Fitness for Duty and #2048 District Pandemic Response.
6. Safety Department Update: Safety & Risk Coordinator Sedivy gave a Safety Department update on training to date, safety improvements, SRD substation safety, Safety Data Sheet (SDS) Vendor, and CL2 Protection & Hoist Improvements.

7. Mount Vernon High School Energy: Engineering Manager Handzlik briefly explained that the PUD will be installing an energy recovery unit to replace the utility of the pressure-reducing valve at 9th & Highland and two EV charging stations on PUD property, including the net meter. The PUD will administer the grant, construction, and EV chargers, including maintenance. The project is being funded by the Clean Energy grant, Trans Alta Coal Transition grant, and IRS credits or additional grants.

A brief discussion ensued.

NEW BUSINESS

8. Service Line Inventory Services: Asset Management Supervisor Wilson explained that the Environmental Protection Agency (EPA) released the Lead and Copper Rule Revisions (LCRR) requiring that water systems submit service line inventories to their state primacy agency. The PUD will be required to inventory the service lines from the main water line to the customer meter and from the customer meter to the home. Hazen and Sawyer was selected to assist with reviewing records and coordinating with the Department of Health (DOH) and EPA.

A brief discussion ensued.

Commissioner Hamburg moved to authorize the General Manager to enter a contract with Hazen and Sawyer in the amount of \$128,041 for service line inventory services.

The motion passed unanimously.

9. Public Records Act Resolution, Policy, and AP&P: Public Records Officer Patiño presented the proposal to update PUD resolutions pertaining to the inspection and copying of PUD records. The update would adopt a formal policy establishing rules and requirements for public records requests along with an AP&P to provide PUD staff with guidelines for conducting requests. The updated resolution, new policy and AP&P will be presented to the board for approval at the May 28 meeting.
10. Information Technology (IT) Policy Adoption: Information Technology Manager Boudreaux gave an overview of IT policies and standards that will also be brought to the board for approval at the May 28 meeting. The policies will define the acceptable and secure ways employees can utilize the organization's information technologies and the standards will provide detailed, actionable specifications on technologies and procedures to ensure consistency and compliance in IT staff practices and procedures.
11. PUD Campus Replacement Project: Task Order #1 Modification #6 to the Agreement Between the PUD and Driftmier: Engineering Manager Handzlik presented a task order modification to pay outstanding invoices of \$157,500 due to refinements to the building design that have required additional services from Driftmier Architects and subcontractors.

A brief discussion ensued.

Commissioner Miller moved to authorize the General Manager to execute Modification #6 for Driftmier Architects.

The motion passed unanimously.

12. Request for Additional Water Treatment Plant (WTP) Operator Position: Manager Sidhu explained that the amendment to the 2024 budget is being requested to add an additional full-time WTP operator position to reduce staff overtime and provide more coverage, so staff reaching maximum personal leave accruals can take personal leave.

A brief discussion ensued.

Commissioner Miller moved to amend the 2024 budget to add a new full-time Water Treatment Plant operator.

The motion passed unanimously.

INFORMATION

- 13. Revisions to AP&P #2047 Fitness for Duty, and #2048 District Pandemic Response
- 14. Monthly Budget Status – March 2024
- 15. Judy Reservoir Data Report

COMMISSIONER COMMENTS

Commissioner Hamburg gave appreciation for Manager Sidhu’s PUD update at the Sedro-Woolley city council meeting.

ADJOURNMENT

Having no further business to come before the board, Commissioner Lindquist moved for adjournment. The motion passed, and the May 14, 2024, meeting adjourned at 5:31 p.m.

ATTEST

Joe Lindquist, President

Corrin Hamburg, Secretary

Andrew Miller, Vice President

As of May 14, 2024

No. 3135

We, the undersigned Board of Commissioners of Public Utility District No. 1 of Skagit County, Washington, do hereby certify that the merchandise and /or services hereinafter specified have been received and are hereby approved for payment in the amount of \$605,250.20 this 14th day of May, 2024.

The total is comprised of the following:

Accounts Payable voucher No. from 29166 through 29203 in the amount of \$481,608.26, Electronic Funds Transfer in the amount of \$123,641.94. Payroll Electronic Funds Transfers and checks No. through in the amount of \$0.00.

Attest:



Manager

Auditor

President

Vice - President

Secretary

Date: 05/10/2024

Page - 1

Voucher	Claimant	Amount
29166	ALL PHASE ELECTRIC SUPPLY	23,049.28
29167	CASCADE NATURAL GAS	1,221.32
29168	CDW GOVERNMENT INC	512.44
29169	CITY OF MOUNT VERNON	93,250.54
29170	SMOKEY POINT CONCRETE	1,362.96
29171	DMH Industrial Electric,Inc	571.48
29172	E&E LUMBER INC	22.11
29173	EARTHWORK SOLUTIONS LLC	229,516.80
29174	ENDURIS WASHINGTON	167.00
29175	ENTERPRISE FM TRUST	993.65
29176	EXPRESS EMPLOYMNT PROFESSIONALS	1,422.80
29177	FRONT DESK	550.00
29178	GEO ENGINEERS INC	2,330.00
29179	GILBERT & GILBERT LAWYERS INC	4,207.50
29180	HYDROLOGY NORTHWEST INC	3,134.64
29181	ICONIX WATERWORKS (US) INC	5,098.12
29182	KVA ELECTRIC, INC.	4,394.26
29183	ANYTIME LABOR SEATTLE LLC	3,933.06
29184	LINDE GAS & EQUIPMENT INC	1,571.45
29185	LOUIS AUTO GLASS INC	671.11
29186	N C MACHINERY CO	3,054.87
29187	NAPA AUTO PARTS	711.28
29188	NATIONAL SAFETY INC	822.53
29189	PACIFIC POWER BATTERIES	157.93
29190	PUGET SOUND ENERGY	620.25
29191	QCC QUALITY CONTROLS CORP	10,649.50
29192	RICHARD H WALSH	17.44
29193	SAN JUAN CABLE	115.90
29194	SECURITY SOLUTIONS NORTHWEST	13,375.45

Voucher	Claimant	Amount
29195	SEDRO WOOLLEY AUTO PARTS INC	86.55
29196	SKAGIT COUNTY PUBLIC WORKS	33.73
29197	THE DRIFTMIER ARCHITECTS P S	67,914.09
29198	Van Putten Septic, Inc.	250.00
29199 - EDI	WA STATE DEPT OF REVENUE	123,641.94
29200	WASHINGTON PUD ASSOCIATION	5,495.00
29201	ASTOUND BUSINESS SOLUTIONS LLC	116.86
29202	WESTSIDE CONCRETE ACCESSORIES	10.88
29203	WILBUR-ELLIS HOLDINGS II INC	195.48
		605,250.20



1415 Freeway Drive | Mount Vernon, Washington 98273 | (360) 424-7104 | SkagitPUD.org

May 28, 2024

MEMORANDUM

TO: Board of Commissioners
FROM: Mark Handzlik PE, Engineering Manager
SUBJECT: Peterson Road Plat Project Acceptance

Requested Action:
Project Acceptance of the Peterson Road Plat Project.

Background:
Reference: CP6916
Location: Burlington
Developer: KSA Investments
Contractor: Dellinger Inc

The PUD has approved the plans and specifications and has inspected the installation of the new water plant within the above project. The Engineering Department has received satisfactory pressure and bacteriological test results. All documentation for this project has been completed

Fiscal Impact:
None.

Enclosures: 1. [CP6916 acceptance map](#)

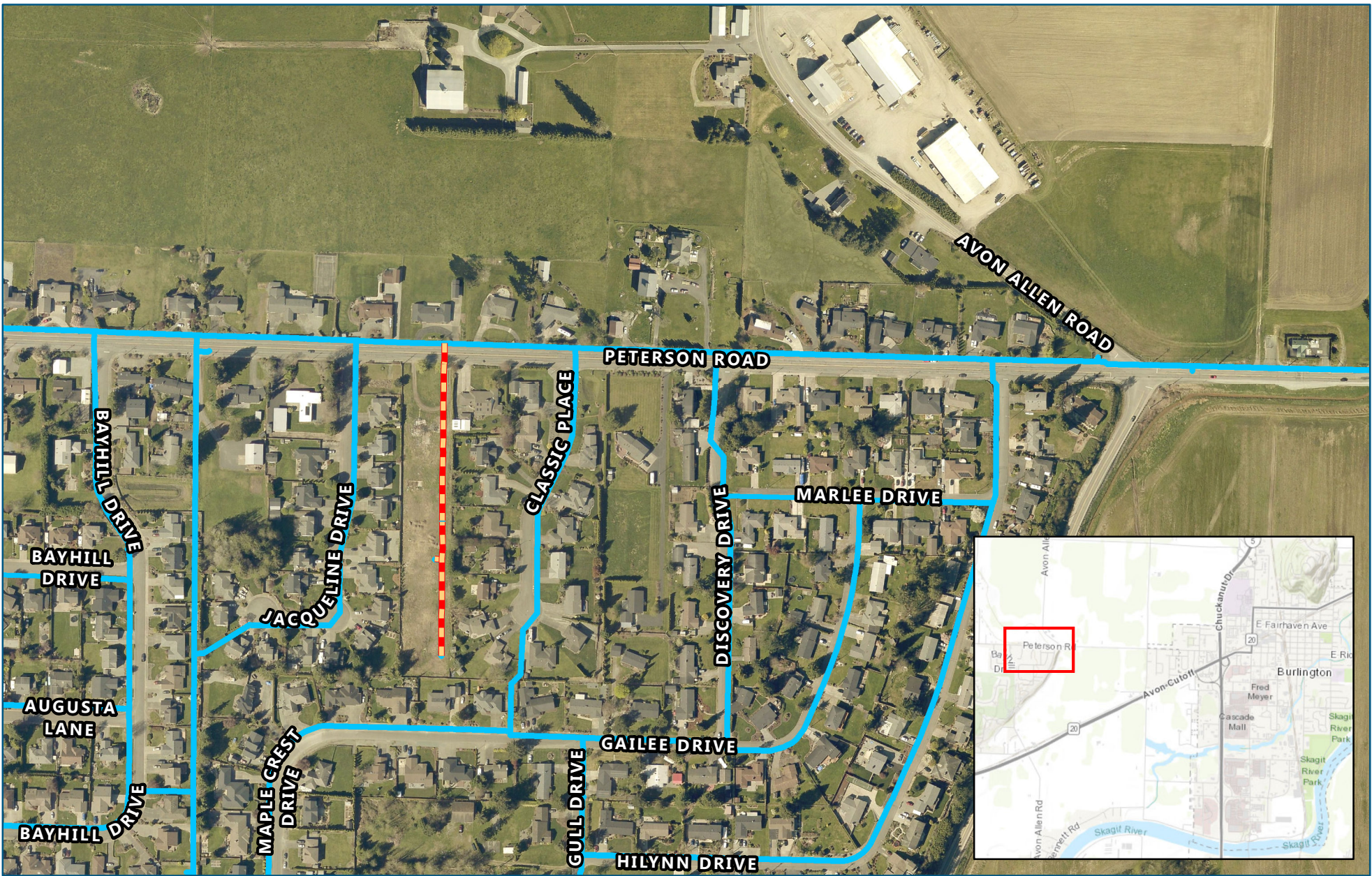

Peterson Road Plat Project Acceptance

- Existing Main
- - - Awaiting Acceptance



0 125 250 500 Feet
 NAD 1983 StatePlane Washington North FIPS 4601 Feet
 Author: Wilson
 5/15/2024

Job Identity: CP6916

This map was created from available public records and existing map sources, not from field surveys. While great care was taken in this process, maps from different sources rarely agree as to the precise location of geographic features. The relative positioning of map features to one another results from combining different map sources without field verification.

The PUD #1 of Skagit County disclaims any warranty of merchantability or warranty of fitness of this map for any particular purpose, either expressed or implied. No representation or warranty is made concerning the accuracy, currency, completeness or quality of data depicted on this map. Any user of this map assumes all responsibility for use thereof, and further agrees to hold the PUD #1 of Skagit County harmless from any damage, loss, or liability arising from the use of this map.

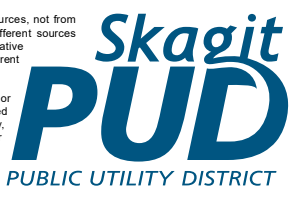



1415 Freeway Drive | Mount Vernon, Washington 98273 | (360) 424-7104 | SkagitPUD.org

May 28, 2024

MEMORANDUM

TO: Board of Commissioners
FROM: Mark Handzlik PE, Engineering Manager
SUBJECT: Mount Vernon Library Project Acceptance

Requested Action:
Project Acceptance of the Mount Vernon Library Project.

Background:

Reference: CP7504
Location: Mount Vernon
Developer: City of Mount Vernon
Contractor: GC: Lydig Construction Inc.; Civil: Pellco Construction Inc.

The PUD has approved the plans and specifications and has inspected the installation of the new water plant within the above project. The Engineering Department has received satisfactory pressure and bacteriological test results. All documentation for this project has been completed.

Fiscal Impact:

None.

Enclosures: 1. [Mount Vernon Library acceptance map](#)

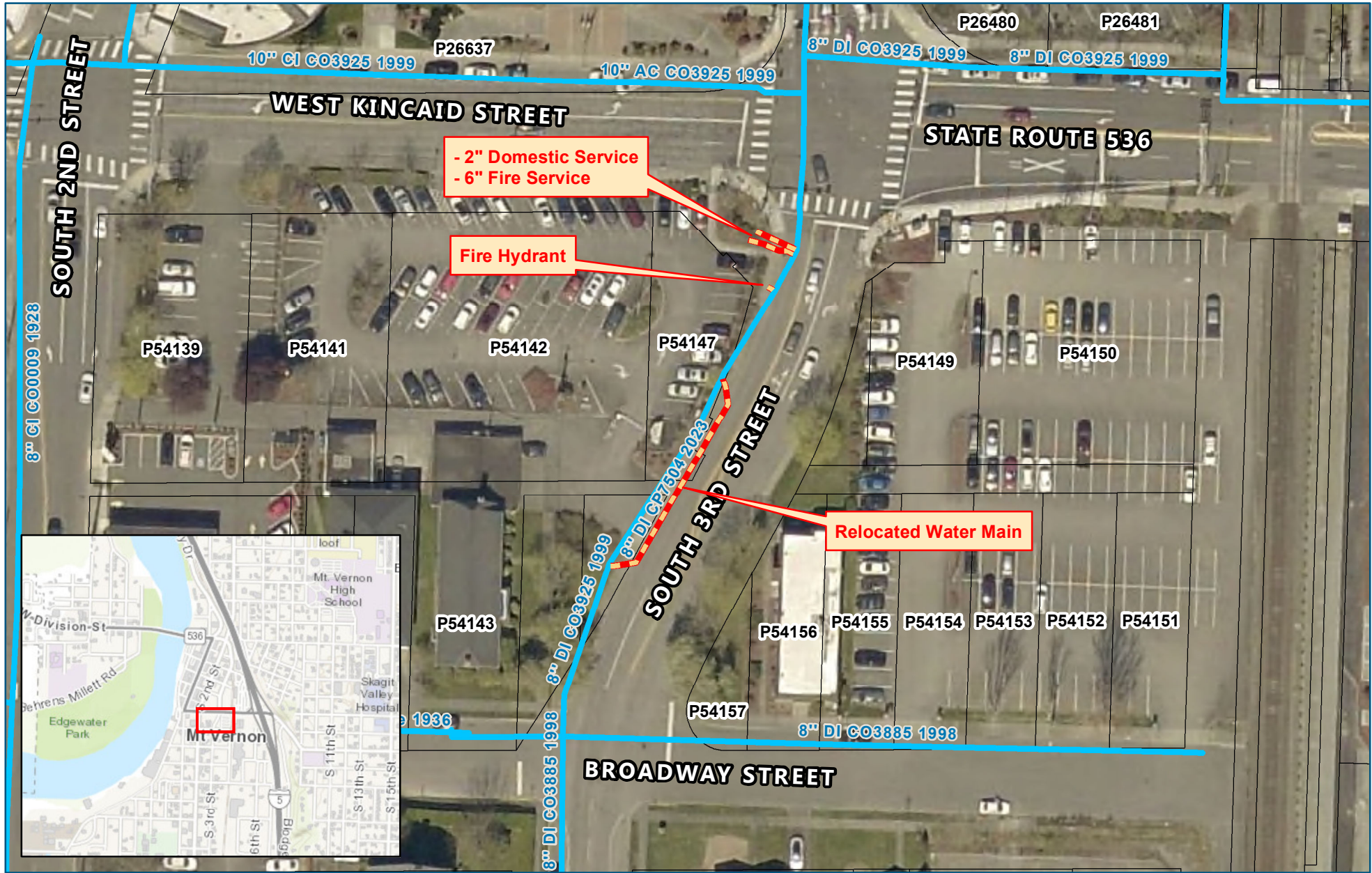

Mount Vernon Library Project Project Acceptance



0 25 50 100 Feet

NAD 1983 StatePlane Washington North FIPS 4601 Feet
Author: wilson
10/5/2023

- Existing Main
- Awaiting Acceptance
- Parcels

Job Identity: CP7504

This map was created from available public records and existing map sources, not from field surveys. While great care was taken in this process, maps from different sources rarely agree as to the precise location of geographic features. The relative positioning of map features to one another results from combining different map sources without field verification.

The PUD #1 of Skagit County disclaims any warranty of merchantability or warranty of fitness of this map for any particular purpose, either expressed or implied. No representation or warranty is made concerning the accuracy, currency, completeness or quality of data depicted on this map. Any user of this map assumes all responsibility for use thereof, and further agrees to hold the PUD #1 of Skagit County harmless from any damage, loss, or liability arising from the use of this map.





1415 Freeway Drive | Mount Vernon, Washington 98273 | (360) 424-7104 | SkagitPUD.org

May 28, 2024

MEMORANDUM

TO: George Sidhu, P.E., General Manager
FROM: Alistair R. Boudreaux, M.P.A., IT Manager
SUBJECT: Information Technology (IT) Policy Adoption

Requested Action:

Approve and authorize general manager to sign Policy #1050, *IT Acceptable Use* and Policy #1051, *IT Information Security* policies.

Background:

The *IT Acceptable Use* and *IT Information Security* policies are essential for safeguarding the PUD’s technological infrastructure and data integrity. These policies define the acceptable and secure ways employees can utilize the organization’s information technologies, including computers, networks, and data.

By clearly outlining what is deemed permissible and what is not, these policies help prevent potential security breaches, data theft, and loss of sensitive information. They also ensure compliance with regulatory requirements, protect against legal issues, and mitigate risks associated with cybersecurity threats.

In addition to the policies presented for approval, IT standards are included. The IT standard provides detailed, actionable specifications on technologies and procedures to ensure consistency and compliance with these policies.

The standards are different from our Administrative Practices and Procedures (AP&P’s) in that they do not apply universally to all staff members. The standards are intended to apply mainly to anyone who is responsible for implementing or maintaining any system that exists in our IT environment.

The following standards have been created to complement the policies:

1. ITS #4001 - Auditing
2. ITS #4002 - Change Management
3. ITS #4003 - Configuration Management
4. ITS #4004 - Data Classification and Handling
5. ITS #4005 - Data Disposal
6. ITS #4006 - Disaster Recovery
7. ITS #4007 - Email Security
8. ITS #4008 - Identification and Authentication
9. ITS #4009 - Media Protection
10. ITS #4010 - Risk Assessment and Management
11. ITS #4011 - Security Awareness Training and Testing

12. ITS #4012 - Security Incident Response
13. ITS #4013 - System Integrity and Vulnerability Management
14. ITS #4014 - System Maintenance

The format of both the policies and the standards follow industry standards that correspond to the Center for Internet Security's (CIS) critical security controls version 8 as well as the National Institute of Standards and Technology's (NIST) security and privacy controls for information systems and organizations SP 800-53 Rev. 5.

These policies and standards will be reviewed on an annual basis and will be revised as the IT landscape evolves.

Fiscal Impact:

There will be no fiscal impact to the PUD.

- Enclosures:
1. 1050 - IT Acceptable Use Policy
 2. 1051 - IT Information Security Policy.pdf
 3. 4001 - Auditing
 4. 4002 - Change Management
 5. 4003 - Configuration Management
 6. 4004 - Data Classification and Handling
 7. 4005 - Data Disposal
 8. 4006 - Disaster Recovery
 9. 4007 - Email Security
 10. 4008 - Identification and Authentication
 11. 4009 - Media Protection
 12. 4010 - Risk Assessment and Management
 13. 4011 - Security Awareness Training and Testing
 14. 4012 - Security Incident Response
 15. 4013 - System Integrity and Vulnerability Management
 16. 4014 - System Maintenance



Information Technology Acceptable Use Policy #1050

In accordance with the authority granted by Resolution #2160-09, an Information Technology Acceptable Use Policy, as described below, is hereby established for the Public Utility District No. 1 of Skagit County (PUD).

Purpose

The appropriate use of Information Technology (IT) plays an integral part in the fulfillment of the PUD's vision, mission, and values. The Acceptable Use Policy (AUP) provides the guiding principles for the use of IT Resources, and users of PUD IT Systems are expected to be good stewards of these resources and act responsibly. All users must comply with federal, state, and local laws and PUD policies when using PUD IT Systems.

Scope

This policy applies to all users of PUD IT Systems, including but not limited to all staff, contractors, or others engaged on the PUD's behalf. It applies to the use of all PUD IT Systems, including systems, networks, and facilities administered by the PUD.

This policy also governs the use of PUD IT Systems, even when carried out on a privately owned computer or other devices that the PUD does not own, manage, or maintain.

Acceptable Use

PUD IT Systems may be used only for authorized purposes – supporting the PUD's business functions. Users are entitled to access only those elements of IT Systems that are consistent with their job duties.

Unacceptable Use

Users are prohibited from the following actions when using PUD IT Systems:

- Unauthorized use of PUD IT Systems for commercial purposes or personal gain
- Transmitting commercial or personal advertisements, solicitations, or promotions

All users are prohibited from using PUD IT Systems in a manner that violates law or policy or adversely affects network service performance. Examples of Unacceptable Use include, but are not limited to, the following:

- Activity that violates federal, state, or local law
- Activity that violates any PUD policy

- Activities that lead to the destruction or damage of equipment, software, or data belonging to others or the PUD
- Circumventing information security controls of PUD IT Systems
- Releasing malware
- Intentionally installing malicious software
- Impeding or disrupting the legitimate computing activities of others
- Unauthorized use of accounts, access codes, passwords, or identification numbers
- Unauthorized use of systems and networks
- Unauthorized monitoring of communications

This list is not complete or exhaustive. It provides examples of prohibited actions. Any user in doubt about the acceptable use of PUD IT Systems should contact the IT Manager for further clarification and assistance.

Definitions

IT Systems

Any equipment or device that can store, process, or transmit electronic PUD data. This includes but is not limited to, servers, personal computing devices, applications, printers, networks (virtual, wired, and wireless), supervisory control and data acquisition (SCADA) systems, building control systems (BCS), phones, and cell phones, tablets, video surveillance equipment, radio equipment, routers, online and offline storage media and related equipment, software, and data files that are owned, managed or maintained by the PUD.

User

A “User” is any person, whether authorized or not, who uses any PUD IT System from any location.

Enforcement and Exceptions

Violations of this policy may result in disciplinary action up to and including termination.

The IT Manager and the General Manager are authorized to grant exceptions to the requirements outlined in this policy. Exception requests must be submitted in writing and include a detailed business case supporting the need for the exception. Any consideration of an exception will require a thorough review of the situation. An approved exception will require the implementation of appropriate compensating controls.

Former Title/Policy #:	N/A
Effective Date:	
Revision Date:	
General Manager Signature:	Date:



Information Security Policy #1051

In accordance with the authority granted by Board Resolution No. 2160-09, an Information Technology Acceptable Use Policy, as described below, is hereby established for the Public Utility PUD No. 1 of Skagit County (PUD).

Introduction

Skagit Public Utility District (PUD) recognizes the importance of maintaining a secure Information Technology (IT) environment to protect its critical infrastructure, data, and business operations. This policy outlines the principles and framework for IT security within the PUD, adhering to the CIA triad of Confidentiality, Integrity, and Availability.

CIA Principles:

- Skagit PUD is committed to achieving the following security objectives:
- Confidentiality: Protecting sensitive information from unauthorized access, disclosure, or use.
- Integrity: Ensuring the accuracy and completeness of information and systems.
- Availability: Maintaining the accessibility of information and systems to authorized users.

CIS Control Framework:

To achieve the CIA principles, Skagit PUD adopts the Center for Internet Security (CIS) Controls framework as its cybersecurity roadmap. The CIS Controls provide a prioritized and actionable set of best practices for mitigating cyber risks.

Policy Objectives:

This policy aims to:

- Establish clear expectations for all PUD employees and contractors regarding IT security practices.
- Define roles and responsibilities for managing IT security risks.
- Provide a framework for implementing and maintaining effective security controls.
- Promote a culture of security awareness and compliance throughout the PUD.

Policy Scope:

This policy applies to all PUD employees, contractors, and any third-party vendors who access PUD IT systems and data. It covers all IT assets, including hardware, software, data, and network resources.

Key Policy Elements:

- Access Control: Implementing appropriate access controls to restrict access to PUD IT resources based on the principle of least privilege.
- Data Security: Protecting sensitive data by using encryption, data loss prevention (DLP) tools, and other appropriate security measures.
- Vulnerability Management: Regularly identify and patch vulnerabilities in PUD IT systems and applications.
- Incident Response: Having a defined process for identifying, responding to, and recovering from security incidents.
- Security Awareness and Training: Providing regular security awareness and training programs to all PUD employees and contractors.
- Third-Party Security: Ensuring that third-party vendors meet appropriate security standards and adhere to PUD security policies.
- Policy Review and Update: Regularly review and update this policy to reflect changes in the IT environment and security landscape.

Roles and Responsibilities:

- Executive Management: Responsible for providing leadership and resources for IT security initiatives.
- IT Manager: Responsible for developing and implementing the PUD's IT security program, including the development of written policies and standards, risk management, and incident response.
- IT Department: Responsible for implementing and maintaining security controls on PUD IT systems and data.
- All Employees and Contractors: Responsible for complying with this policy and taking appropriate measures to protect PUD IT resources.

Enforcement:

Violations of this policy may result in disciplinary action up to and including termination.

The IT Manager and the General Manager are authorized to grant exceptions to the requirements outlined in this policy. Exception requests must be submitted in writing and include a detailed business case supporting the need for the exception. Any consideration of an exception will require a thorough review of the situation. An approved exception will require the implementation of appropriate compensating controls.

Former Title/Policy #:	N/A
Effective Date:	
Revision Date:	
General Manager Signature:	Date:



Auditing IT Standard #4001

Purpose

Skagit PUD monitors information systems to detect attacks, indicators of potential attacks, and unauthorized use in accordance with established monitoring objectives.

Scope

The scope of this standard is applicable to all information resources owned or operated by Skagit PUD. All users, including employees, third-party providers, and contractors, are responsible for adhering to this standard.

Statement of Standard

1. General Audit Procedures

- a. Skagit PUD will conduct regular reviews of records within information systems, such as system event logs, access reports, and incident tracking reports. These reviews will occur on a quarterly basis.
- b. Responsibility for reviewing information system activity is assigned to the IT department.
- c. Audits will be conducted based on risk management decisions made by the data owner.
- d. Document the occurrence of all reviews in a log (see Appendix A). This documentation should include:
 - i. What was reviewed;
 - ii. When the review took place;
 - iii. The outcome (e.g., if unusual activity is discovered);
 - iv. Steps taken to remediate unwanted activity from occurring again.

2. Auditable Events

- a. Skagit PUD will implement a process, including the use of hardware and software where appropriate, to capture and monitor activity on information systems. The following system events will be captured and monitored:
 - i. Device startup and shutdown;
 - ii. Duration of login periods;
 - iii. Whether data has been viewed or modified;
 - iv. Failed login attempts;
 - v. Use of elevated privileges;
 - vi. Security or privacy attribute changes;

- vii. Security incidents.
 - b. Configure systems to send notifications to the IT department in the event of audit logging failures. Failures may include:
 - i. Software and Hardware errors;
 - ii. Failures in audit log capturing mechanisms;
 - iii. Reaching or exceeding audit log storage capacity.
- 3. **Audit Records**
 - a. Audit records should include the following:
 - i. Type of event;
 - ii. Date and time of the event;
 - iii. The component of the information system where the event occurred;
 - iv. The source of the event;
 - v. The outcome of the event (success or failure);
 - vi. The identity of any individuals, subjects, or objects/entities involved with the event.
 - b. Skagit PUD will deploy a Security Information and Event Management (SIEM) tool to aggregate records into a centralized location to assist with audit reviews.
 - c. System event logs must be stored for a sufficient amount of time to support the cadence of periodic audits.
 - i. To accommodate retention periods, event logs can be stored on an alternate system or transitioned to an offline server, as needed, due to space constraints on primary systems.
 - d. Controls are established to protect audit records, including limiting access to authorized individuals.
 - i. Configure the system to send notifications to the IT department should unauthorized access, modification, or deletion of audit information be detected.

Enforcement and Exceptions

Violations of this standard or failure to implement the procedures of this standard may result in disciplinary action up to and including termination.

The General Manager or the IT Manager is authorized to grant exceptions to the requirements set forth in this standard. Exception requests must be submitted in writing and must include a detailed business case supporting the need for the exception. Any consideration of an exception will require a thorough review of the situation by the IT Manager. An approved exception will require the implementation of appropriate compensating controls.

References:

NIST 800-53 Rev 5: AU 1-13

CIS Controls: 6, 8, 13, 14, 18

Former Title/Policy #:	N/A
Effective Date:	
Revision Date:	
General Manager Signature:	Date:

Appendix
Audit logging review tracking

What was reviewed?	Date	Outcome	Remediation Efforts (as applicable)
EXAMPLE: [[System Event Logs]]	[[10/1/2017]]	[[Unauthorized use of elevated credentials]]	[[Investigation ongoing]]



Change Management IT Standard #4002

Purpose

Skagit PUD will manage changes to systems in a well-communicated, planned, and predictable manner. This minimizes unplanned outages as well as unforeseen system issues and allows the organization to plan accordingly. Effective change management requires planning, monitoring, communication, rollback, and follow-up procedures to reduce negative impacts on the PUD's users.

Scope

The scope of this standard is applicable to all information resources owned or operated by Skagit PUD. All users, including employees, third-party providers, and contractors, are responsible for adhering to this standard.

Statement of Standard

1. All changes to information resources (e.g., operating system, computing hardware, networks, applications, data centers, etc.) are subject to this standard and must follow appropriate change management procedures.
2. A change request must be submitted prior to changes being made. Change requests are to be submitted via email to itsupport@skagitpud.org, with the subject line: "Request for change – [system name]."
3. The IT manager will review the request for change and either approve (at times with modifications) the request for deployment or reject it.
4. In preparation for approval or rejection, the IT Manager with appropriate IT personnel will determine the following:
 - a. Designate the application owner of the system to be changed.
 - b. Review and identify potential risks associated with the change implementation (to minimize the risk of disruption of service caused by the change).
 - c. The overall impact on other systems or impact on normal operation during and following the change implementation (inherent risk).
 - d. The appropriate group within the PUD will communicate the change.
 - e. The best time/date for implementation (to minimize the impact on users).
5. The IT Manager with appropriate IT personnel will review the following:
 - a. Review previous, similar changes and the results of the changes in an attempt to avoid any repetition of mistakes or negative impacts on users or

organizational services.

- b. Ensure that the changes do not negatively impact the overall system security.
6. If the IT Manager rejects the change request, the initial requester will be notified.
7. If the IT Manager approves the change, the following approval and audit process will be followed:
 - a. The approved change request will be submitted to the application owner and the appropriate IT support personnel.
 - b. Any issues identified during the review process that require special considerations (e.g., identified risks, potential security controls, etc.).
 - c. The application owner and IT support personnel, where applicable, will review, test, and approve the revision prior to implementation into the production environment.
 - d. The revision will be released to the production environment by the application owner.
 - e. The application owner and IT support personnel will actively monitor and review activities associated with the implemented change for a time period of two weeks.
8. Documentation of any change to any information resource will be maintained. This documentation will be securely stored in the District's document retention system. The following type of information will be documented:
 - a. Date/time of the change.
 - b. Expected duration or length of time required to implement the change.
 - c. A brief description of the change - including what is to be changed and the overall effect of the change.
 - d. The name of the individual responsible for implementing the change.
 - e. Indication of successful implementation or unsuccessful implementation of the change.
 - f. An analysis of "lessons learned" for the changes due to any deviation from the plan, resulting in an unplanned disruption of service, corruption of data, or disclosure of confidential information.

Enforcement and Exceptions

Violations of this standard or failure to implement the procedures of this standard may result in disciplinary action up to and including termination.

The General Manager or the IT Manager is authorized to grant exceptions to the requirements set forth in this standard. Exception requests must be submitted in writing and must include a detailed business case supporting the need for the exception. Any consideration of an exception will require a thorough review of the situation by the IT Manager. An approved exception will

require the implementation of appropriate compensating controls.

References:

NIST 800-53 Rev 5: CM-3, CM-4, CM-5

CIS Controls: 2, 4, 5, 6, 11, 12

Former Title/Policy #:	N/A
Effective Date:	
Revision Date:	
General Manager Signature:	Date:



Configuration Management IT Standard #4003

Purpose

The purpose of this standard is to ensure that all Skagit PUD laptops, desktops, systems, and other assets are configured to Skagit PUD minimum required secure baselines to maintain integrity, confidentiality, and availability of those assets. This standard ensures that Skagit PUD assets are tracked and maintained securely and properly throughout their life cycle.

Scope

The scope of this standard is applicable to all information resources owned or operated by Skagit PUD. All users, including employees, third-party providers, and contractors, are responsible for adhering to this standard.

Statement of Standard

1. Skagit PUD creates and documents a baseline configuration for all assets managed by Skagit PUD. These baselines must be followed at all times:
 - a. Windows OS Baseline:
 - i. Must have Endpoint Protection installed and running at all times.
 - ii. Must be added to Skagit PUD's Mobile Device Management software.
 - iii. Must have Data Loss Prevention software installed and running at all times.
 - iv. Must have the Skagit PUD's Virtual Private Network profile for remote work.
 - v. Must follow Skagit PUD's Password standard for all user profiles.
 - vi. Must be up to date with all applicable security patches.
 - vii. Must have Google Chrome installed and set as the default browser.
 - viii. Must have only IT-approved software installed.
 - ix. Must be segmented into the appropriate VLAN (dependent on role and department).
 - x. Must follow the standard Skagit PUD device naming convention (see Appendix A).
 - xi. Must have Full Disk Encryption enabled.
 - b. Browser Extensions Baseline
 - i. Default browser is Google Chrome.
 - ii. Endpoint Verification
 - iii. RoboForm for password management.
 - iv. Microsoft Teams and Zoom, for videoconferencing.

- c. Printer and Scanner Baseline
 - i. Must have all unnecessary ports and services disabled.
 - ii. Must follow Skagit PUD’s Password Standard for all user profiles that are local on the printer, scanner, and print server.
 - iii. Must be up to date with all applicable security patches.
 - iv. Must be segmented into the appropriate printer VLAN.
 - v. Must leverage full disk encryption for all attached drives
 - vi. Upon decommissioning a printer, all hard drives must be removed from the device and wiped prior to the printer leaving the facility.
 - vii. Must follow the standard Skagit PUD device naming convention.
- 2. All baseline configurations will be reviewed and updated on a quarterly basis or whenever the environment changes requiring a review.
- 3. All changes must follow the Change Management standard before any new changes are applied to the established baseline configurations.

Enforcement and Exceptions

Violations of this standard or failure to implement the procedures of this standard may result in disciplinary action up to and including termination.

The General Manager or the IT Manager is authorized to grant exceptions to the requirements set forth in this standard. Exception requests must be submitted in writing and must include a detailed business case supporting the need for the exception. Any consideration of an exception will require a thorough review of the situation by the IT Manager. An approved exception will require the implementation of appropriate compensating controls.

References:

NIST 800-53 Rev 5: CM-2

CIS Controls: 5, 11

Former Title/Policy #:	N/A
Effective Date:	
Revision Date:	
General Manager Signature:	Date:

Appendix A Skagit PUD IT Hardware Naming Conventions

Skagit PUD has adopted the following naming conventions for PUD-owned devices connected to the PUD's network in order to a) uniquely identify devices and b) reduce the possibility of device naming conflicts. This naming format is recommended in order to include the most information possible using the 15-character maximum imposed by Microsoft Active Directory.

Laptops and Desktops

In general, laptops and desktops should begin with the first letter of the user's first name, and the user's entire last name, and end with either "lpt" for laptop or "dsktp" for desktop. Elements of the device name should be separated, whenever possible, by a dash (-). A few examples:

- Correct: nsemrau-lpt (11 characters)
- Correct: lgonzalez-dsktp (15 characters)

In cases where a worthwhile name would exceed 15 characters, it is permissible to adjust the name to signify to whom the device has been assigned. For example:

- Incorrect: rhumerickhouse-lpt (18 characters)
- Correct: ronh-lpt (8 characters)
- Incorrect: aboudreaux-dsktp (16 characters)
- Correct: boudreaux-dsktp (15 characters)

Servers

The naming convention for servers

Prefix-Function-Environment-Number

- **Prefix** will denote the type of device, such as a server.
- **Function/Role:** Include the server's function or role, such as "WEB" for web servers, "DB" for database servers, or "APP" for application servers.
- **Environment:** Add an identifier for the environment, such as "PROD" for production, "DEV" for development, "TEST" for testing.
- **Number:** Add a sequential number.

Examples: S-WEB-PROD-01



Data Classification and Handling IT Standard #4004

Purpose

Skagit PUD will establish a framework and define terminology for classifying data. Data will be classified based on its confidentiality, availability, and integrity (CIA). Data will be classified based on business needs and legal requirements.

Scope

The scope of this standard is applicable to all information resources owned or operated by Skagit PUD. All users, including employees, third-party providers, and contractors, are responsible for adhering to this standard.

Statement of Standard

1. The IT Manager is responsible for the following:
 - a. Development, implementation, maintenance, and compliance monitoring of information classifications as defined and assigned by this policy.
 - b. Ensuring the effectiveness of deployed controls to conserve information classifications of all systems.

2. The information classification process must include the following:
 - a. Identification of information assets:
 - i. Identification of information assets involves creating an inventory of all information assets within the organization. The following items need to be considered when constructing this inventory:
 1. Grouping of information assets.
 2. Determining the information owner.
 3. Determining the information custodian.
 4. Identifying information assets.
 - b. Classification of information assets by confidentiality, integrity, and availability (CIA). CIA classifications play an important role in protecting sensitive, private information from unauthorized access. These classifications will assist Skagit PUD in implementing security controls as well as in planning contingency and disaster recovery efforts:
 - i. Confidentiality classifications assist in defining the access restrictions needed to prevent data disclosure in order to protect personal information and secure organization data.
 - ii. Integrity classifications ensure the authenticity of information by protecting it against improper modification or deletion.

- iii. Availability classifications ensure reliable access to information and the ability to use said information within a short time span.
 - iv. The Data Owner is responsible for the determination of the classification of information assets by evaluating the criticality and data associated with the asset.
 - 1. If appropriate, subject matter experts who have specific knowledge about an information asset, may be utilized during the classification process. The IT Manager, Network Administrator or Application Owner may also be called upon to advise and assist in determining classification categories.
 - v. All Skagit PUD-owned information assets will be classified according to confidentiality, integrity, and availability to establish a baseline.
 - vi. Skagit PUD will use these classifications to assist in building contingency plans and recovery operations as well as to aid in determining baseline security controls for the protection of data and assets.
3. Confidentiality Classifications
- a. All information systems and assets will carry a confidentiality classification as defined by one of the following categories:
 - i. **Confidential** – The assets which have high confidentiality value belong to this category. Only a limited set of authorized users will access these information assets. Examples include internal business strategy and personnel files.
 - ii. **Project / Process / Department specific** – The assets that contain data pertaining to the needs of a specific department, project team, or business process, belong to this category. Such information assets will be accessible to members of the concerned department, project, or business process only.
 - iii. **Internal** – The information assets which can be distributed within all offices of Skagit PUD belong to this category. Examples are office orders and internal memos.
 - iv. **Public** – The assets that can be disseminated to the general public belong to this category. Examples include an annual financial report of Skagit PUD and information displayed on Skagit PUD’s website.
 - b. If an asset has not been assigned a confidentiality classification, the data will have a default classification of **Internal**.
 - c. If an asset falls into multiple classifications, the asset must be classified at the higher level.
 - d. Handling and labeling of all assets will be according to its indicated classification level.
 - e. Depending on the classification of information, electronic transmission, copying, and distribution of copies of such information, will require prior approval of the General Manager or IT Manager as applicable.
 - f. Mailing and/or shipment of confidential information will require that information be sent through a reputable mail service/courier with proper authentication and tracking.

- g. Confidential information will be stored with proper security and/or in safe lockers.
 - h. Disposition of Confidential and Project/Process/Department-specific information will require shredding in the presence of the General Manager, Public Records Officer, or Project Manager as applicable.
 - i. Appropriate access restrictions will be applied to prevent access from unauthorized personnel.
 - j. A formal record of the authorized recipients of data will be maintained.
 - k. All copies of media will be clearly marked for the attention of the authorized recipient.
 - l. The distribution of data will be based on “need to know” and “need to use” principles.
 - m. Distribution lists and lists of authorized recipients will be reviewed at quarterly intervals.
4. Availability Classification
- a. All information systems and assets will carry an availability classification as defined by one of the following categories:
 - i. **High** - The potential impact is high if— The lack of availability could be expected to have a severe or catastrophic adverse effect on organizational operations, organizational assets, or individuals.
 - 1. A severe or catastrophic adverse effect means that, for example, the loss availability might:
 - a. cause a severe degradation in or loss of mission capability to an extent and duration that the organization is not able to perform one or more of its primary functions;
 - b. result in major damage to organizational assets;
 - c. result in major financial loss; or
 - d. result in severe or catastrophic harm to individuals involving loss of life or serious life-threatening injuries.
 - ii. **Moderate** - The potential impact is moderate if— The lack of availability could be expected to have a serious adverse effect on organizational operations, organizational assets, or individuals.
 - 1. A serious adverse effect means that, for example, the loss of availability might:
 - a. cause a significant degradation in mission capability to an extent and duration that the organization is able to perform its primary functions, but the effectiveness of the functions is significantly reduced;
 - b. result in significant damage to organizational assets;
 - c. result in significant financial loss; or
 - d. result in significant harm to individuals that does not involve loss of life or serious life-threatening injuries.
 - iii. **Low** - The potential impact is low if—The lack of availability could be expected to have a limited adverse effect on organizational operations, organizational assets, or individuals.

1. A limited adverse effect means that, for example, the loss of confidentiality, integrity, or availability might:
 - a. cause a degradation in mission capability to an extent and duration that the organization is able to perform its primary functions, but the effectiveness of the functions is noticeably reduced;
 - b. result in minor damage to organizational assets;
 - c. result in minor financial loss; or
 - d. result in minor harm to individuals.

5. Integrity Classification

- a. All information systems and assets will carry an integrity classification as defined by one of the following categories:
 - i. **High** - Severe and/or catastrophic consequences are expected from the unauthorized modification or deletion of the specific data, affecting Skagit PUD’s operations, assets and/or individuals.
 - ii. **Medium** - Serious consequences are expected from the unauthorized modification or deletion of the specific data, affecting Skagit PUD’s operations, assets and/or individuals.
 - iii. **Low** - Limited consequences are expected from the unauthorized modification or deletion of the specific data, affecting Skagit PUD’s operations, assets and/or individuals.

Enforcement and Exceptions

Violations of this standard or failure to implement the procedures of this standard may result in disciplinary action up to and including termination.

The General Manager or the IT Manager is authorized to grant exceptions to the requirements set forth in this standard. Exception requests must be submitted in writing and must include a detailed business case supporting the need for the exception. Any consideration of an exception will require a thorough review of the situation by the IT Manager. An approved exception will require the implementation of appropriate compensating controls.

References:

NIST 800-53 Rev 5: RA-2

CIS Controls: 3, 5 Former Title/Policy #:	N/A
Effective Date:	
Revision Date:	
General Manager Signature:	Date:



Data Disposal IT Standard #4005

Purpose

This standard aims to ensure that essential records and documents are properly destroyed and that records that Skagit PUD no longer require or are no longer beneficial are disposed of as soon as possible. This standard should enable Skagit PUD's personnel to understand their responsibilities concerning the disposal of any type of information created, received, or transmitted within the organization, regardless of physical format.

Scope

The scope of this standard is applicable to all information resources owned or operated by Skagit PUD. All users, including employees, third-party providers, and contractors, are responsible for adhering to this standard. This standard applies to all records generated during Skagit PUD's operation, including original documents and duplicates.

Statement of Standard

1. Record Retention Schedule
 - a. The Record Retention Schedule, contained in the appendix of this document, is authorized as the maintenance and retention schedule for records created, maintained, and stored at Skagit PUD. A record must not be retained beyond the period indicated in the Record Retention Schedule unless given a sound and written business reason for its continued retention.
 - i. The Public Records Officer will annually review the record retention and disposal schedule and monitor compliance with this standard.
2. Exceptional Circumstances
 - a. If Skagit PUD is served with a subpoena or a request for documents is made, or if any employee learns that Skagit PUD is the subject of a government audit or investigation, the General Manager must be notified.
 - b. In the case of an exceptional circumstance, no documents may be disposed of. Skagit PUD will communicate through the Public Records Officer to cease the disposal of papers.
3. Data Destruction
 - a. Third Party Data Disposal
 - i. When a piece of data is no longer required for business purposes, it should be deleted, as long as doing so does not violate any regulations, Skagit PUD's data retention policy, or any of Skagit PUD's clients, subsidiaries, or other entities.

1. Disposal includes but is not limited to, clearing, purging, or destroying.
- ii. If client data is backed up on production systems, to adhere to Skagit PUD's data retention and contractual obligations, any data that is no longer required should be sanitized.
- b. Device Destruction and Sanitization
 - i. Skagit PUD only allows disposal without sanitization when the data would not impact the organization's goals, result in harm to organizational assets, and would not cause any financial loss or harm to any particular person.
 1. Sanitization is the process of purposefully deleting or destroying data from a storage device so that it cannot be recovered.
 - ii. Skagit PUD ensures storage media for laptops are not sold.
 - iii. Before giving ownership of a laptop to another employee or destroying said laptop, all media should be sanitized.
 - iv. Skagit PUD employs successive writes of patterned data to ensure that data cannot be easily recovered using traditional methods or software. If purging the media is required, a minimum of seven passes qualifies as a purging process.
 - v. A sanitization verification process will be completed to ensure that Skagit PUD truly cleaned the target data. A complete reading of all accessible areas will be done to verify that the data is irretrievable.
- c. Data Retrieval Prevention
 - i. To prevent data retrieval, Skagit PUD ensures solid-state devices, SD cards, and USB sticks are physically destroyed, and the proper safety procedures are followed.
- d. Documentation
 - i. For each piece of hard or soft copy media that has been sanitized, the IT Manager must fill out a form with all information pertaining to the media being destroyed.
 1. The confidentiality of the data will determine whether to complete the record or form for data destruction. The organization may decide not to complete a form for a large number of devices that contain data with very low confidentiality data.
 2. The individual sanitizing the media will enter the information into the Record of Sanitation Form (Appendix B) and scan each bar code as they are being cleaned, if necessary.

Enforcement and Exceptions

Violations of this standard or failure to implement the procedures of this standard may result in disciplinary action up to and including termination.

The General Manager or the IT Manager is authorized to grant exceptions to the requirements set forth in this standard. Exception requests must be submitted in writing and must include a detailed business case supporting the need for the exception. Any consideration of an exception will require a thorough review of the situation by the IT Manager. An approved exception will

require the implementation of appropriate compensating controls.

References:

NIST 800-53 Rev 5: MP-6

CIS Controls: 8, 13

Former Title/Policy #:	N/A
Effective Date:	
Revision Date:	
General Manager Signature:	Date:

**Appendix A
Record Retention Schedule**

Data Owner	<i>General Manager</i>		
CORPORATE RECORDS			
Data Type	Storage Location	Retention Period	Action [[Delete/ Archive]]
Articles of Incorporation, Bylaws, Corporate Seal		Permanent Record	
Board policies, resolutions, meeting minutes and committee meeting minutes		Permanent Record	
Contracts		Permanent Record or 6 years after expiration	
Buy-sell agreements		Permanent Record	
Construction documents		Permanent Record	
Fixed Asset Records		Permanent Record	
E-mails (business-related)		3 years	

Data Owner	<i>General Manager</i>		
PROPERTY RECORDS			
Data Type	Storage Location	Retention Period	Action [[Delete/ Archive]]
Property Deeds, Assessments, Licenses, Rights of Way		Permanent Record	
Original Purchase/Sale/Lease Agreements		Permanent Record or 6 years after expiration	

Construction documents		Permanent Record	
------------------------	--	------------------	--

Data Owner	<i>Finance Manager</i>		
TAX RECORDS			
Data Type	Storage Location	Retention Period	Action [[Delete/Archive]]
Payroll tax withholdings		7 years	
Tax Returns: Income, Franchise, Property		7 years	
Payroll Tax Records		7 years	

Data Owner	<i>Finance Manager</i>		
ACCOUNTING AND FINANCE RECORDS			
Data Type	Storage Location	Retention Period	Action [[Delete/Archive]]
Accounts Payable and Receivables ledgers and schedules		7 years	
Audit reports and financial statements		Permanent	
Bank statements, canceled checks, deposit slips		7 years	
Annual plans and budgets		2 years	
Electronic fund transfer documents		7 years	
Payroll registers (gross and net)		Permanent Record or 3 years from the last date of entry	

Employee expense reports		7 years	
Invoices		7 years	

Data Owner	<i>HR Manager</i>		
PERSONNEL RECORDS			
Data Type	Storage Location	Retention Period	Action [[Delete/Archive]]
EEO-1 Reports (Employer Information Report)		Filed annually with the EEOC and the Department of Labor, Office of Federal Contract Compliance Programs, most recent kept on file	
Employee applications and resumes		1 year from date of making record	
Employee benefit plans subject to ERISA		7 years	
Collective bargaining agreements		3 years	
Benefits descriptions per employee		Permanent Record or 4 years	
W-2 and W-4 Forms and Statements		As long as the document is in effect or 4 years	
Time cards, wage rate tables, pay rates, work and time schedules, records of additions to or deductions from wages, etc.		2 years	
Employee offer letters		1 year from date of making record	

Records relating to background checks on employees		5 years from effective date	
Employment contracts		3 years from termination	
I-9 Forms		3 years after date of hire	
Salary schedules; ranges for each job description		2 years	
Workers' compensation records		Duration of employment + 30 years	

Appendix B Record of Sanitization

Record of Sanitization		
Personnel Information		
Name	Title	
Organization:	Location:	Phone:
Data/Media/ Storage Information		
Make/ Vendor:	Model #:	
Serial Number:		
Media Type:	Property ID:	
Classification:	Data Backed Up:	
Backup Location		
Method Used:	Notes:	
Media Destination		
[[Internal Re-use, External location for destruction, or external dump location]]		
Signature		
Signature:		
Validation		
Signature:		



Disaster Recovery Planning IT Standard #4006

Purpose

Skagit PUD is responsible for developing, distributing, coordinating, reviewing, updating, communicating, and protecting a disaster recovery plan.

Scope

The scope of this standard is applicable to all information resources owned or operated by Skagit PUD. All users, including employees, third-party providers, and contractors, are responsible for adhering to this standard.

Statement of Standard

1. General
 - a. Skagit PUD leaders are responsible for matters involving the establishment and maintenance of the disaster recovery plan. This includes developing and approving the plan, allocating resources, and prioritizing the recovery plan and related activities.
 - b. The Skagit PUD IT department is responsible for ensuring the ongoing availability of the information resources necessary for continued operations, as defined in the disaster recover plan.
 - c. The disaster recovery plan must align with the organization's other plans that are related to emergency or unexpected situations.
2. Data Backup
 - a. The frequency and extent of backups will be determined by: The importance of the information as defined in the Skagit PUD data classification standard the potential impact of data loss or corruption; and the data owner's risk management decisions.
 - b. Data backups will be stored at an alternate storage location, away from the primary storage site. This is the iLand backup facility in Texas.
 - c. The backup and recovery processes for each system, including those for offsite storage, will be documented and reviewed on an annual basis.
 - d. Skagit PUD will have a defined and documented data backup schedule.
 - e. Processes must be in place to verify the success of information resource backups.
 - f. Backup media must have, at a minimum, the following information that can be readily identified:
 - i. System name;

- ii. Creation date;
 - iii. Sensitivity classification of the backup data;
 - iv. Contact information identifying the data owner.
 - g. Protect data backups from unauthorized access.
3. Disaster Recovery Plan
- a. The documented disaster recovery plan will include the following elements:
 - i. A business impact analysis (BIA) that systematically assesses the potential impacts of a loss of business functionality due to an interruption of computing and/or infrastructure support services resulting from various events or incidents. The BIA will identify the following elements:
 - 1. Mission-critical information resources (i.e., specific system resources required to perform critical functions), including:
 - A. Internal and external points of contact for personnel that provide or receive data or support interconnected systems.
 - B. Supporting infrastructure such as electric power, telecommunications connections, and environmental controls.
 - 2. Disruption impacts and allowable outage times to include:
 - A. Effects of an outage over time to assess the maximum allowable time that a resource may be unavailable before it prevents or inhibits the performance of an essential function.
 - B. Effects of an outage across related resources and dependent systems to assess the cascading effects on associated systems or processes.
 - 3. Recovery priorities that consider geographic areas, accessibility, security, environment, and cost. This may include a combination of:
 - A. Preventive controls and processes such as backup power, excess capacity, environmental sensors, and alarms.
 - B. Recovery techniques and technologies such as backup methodologies, alternate sites, software and hardware equipment replacement, implementation roles and responsibilities.
 - ii. Written disaster recovery plans that include the following:
 - 1. Identification of a disaster recovery team who is responsible for developing, implementing, and maintaining the recovery plan.
 - 2. Identification and assessment of disaster risks. This will assist the team in creating appropriate recovery strategies and resources required to recover from disasters while meeting the requirements of the disaster recovery plan (such as limiting disruption impacts and meeting recovery priorities).

- A. This will include identifying items related to natural disasters, man-made emergencies, and technology-related incidents.
 3. Identification of critical applications, documents, and resources.
 4. Identification of an alternate site or communications channel with the equipment and communications necessary for meeting the disaster recovery plan requirements (such as limiting disruption impacts and meeting recovery priorities).
 - b. The Skagit PUD disaster recovery plan will be distributed to key personnel and a copy must be stored offsite.
 - c. Disaster recovery plans must be reviewed and updated on an annual basis, and after significant changes occur in the environment where information systems operate.
4. Training and Testing
 - a. Training and testing of disaster recovery plan procedures must be conducted on an annual basis.
 - i. Disaster recovery plan testing includes the use of checklists, walk-throughs or tabletop exercises, and simulations (simulating partial or full interruptions).
 - ii. Disaster recovery plan testing should include a determination of the effects on organizational operations, assets, and individuals as a result of taking actions to follow the disaster recovery plan.
 - iii. The lessons learned from testing exercises will be incorporated into revisions of the disaster recovery plan.
 - iv. Backups will be periodically tested to ensure that they are recoverable.

Enforcement and Exceptions

Violations of this standard or failure to implement the procedures of this standard may result in disciplinary action up to and including termination.

The General Manager or the IT Manager is authorized to grant exceptions to the requirements set forth in this standard. Exception requests must be submitted in writing and must include a detailed business case supporting the need for the exception. Any consideration of an exception will require a thorough review of the situation by the IT Manager. An approved exception will require the implementation of appropriate compensating controls.

References:

NIST 800-53 Rev 5: CP-1, CP-2, CP-3, CP-4, CP-6, CP-7, CP-8, CP-9, CP-10

CIS Controls: 1, 2, 3, 4, 10, 11, 12

Former Title/Policy #:	N/A
Effective Date:	
Revision Date:	
General Manager Signature:	Date:



Email Security IT Standard #4007

Purpose

Email is a crucial part of organizational communication, but because it could risk the network's security, it poses a unique set of problems. This standard defines expectations for appropriate, safe, and efficient email use and security.

Scope

The scope of this standard is applicable to all information resources owned or operated by Skagit PUD. All users, including employees, third-party providers, and contractors, are responsible for adhering to this standard.

Statement of Standard

1. Employee Email Security
 - a. Employees must adhere to the IT Acceptable Use Standard when sending and receiving emails from work accounts. Skagit PUD will manage the email system to encourage employee productivity while working and lower the possibility of an email-related security issue.
 - b. Emails from a Skagit PUD email account must be carefully addressed. Employees should be aware that once email leaves Skagit PUD's network, Skagit PUD no longer has any control over it.
 - c. To prevent unintentional information disclosure, employees must exercise extreme caution while entering addresses when email address auto-complete capabilities are activated, using the reply-all function, or distribution lists.
 - d. Employees are strictly prohibited from deleting emails to cover up a breach of this standard or another organizational policy or incident. Furthermore, emails that might be important to an ongoing investigation or legal dispute should not be destroyed.
 - e. Employees must use OneDrive for sending files that contain sensitive information or large attachments. Employees understand that Skagit PUD has limited authority over the contents of inbound emails. Emails may contain material that the employee finds objectionable. Avoid opening emails that appear suspicious and should alert their supervisors if they have any concerns about a particular email or think it may contain illicit material.
 - f. Employees must use only their official Skagit PUD email address and not provide access to their account to anyone else.

- g. Controlling access to Skagit PUD's email system is crucial for maintaining its security. Employees shouldn't divulge their password and email ID to unapproved parties.
 - h. Employees are not to impersonate another employee. The IT Acceptable Use Standard must be followed by the employee to avoid email accounts being used by unauthorized users.
 - i. It is forbidden to forge, alter or manipulate header data in email communications, including but not limited to the source address, destination address, and timestamps.
 - j. Employees are not allowed to share or publish internal mailing lists with people who are not employees. Trade secrets, copyrighted content, and private or confidential information should not be sent across Skagit PUD systems unless they are digitally signed and encrypted.
2. Email Account Creation
- a. The IT department will create email accounts for any employee who needs to send and receive organization emails.
 - b. Skagit PUD will disable the employee's access to the account by changing the password, deactivating the account, or another way when the employee leaves the organization, Skagit PUD or has their email access officially terminated.
 - c. The organization may continue forwarding incoming emails from that account to another employee or set up an auto-response to inform the sender that Skagit PUD no longer employs the employee. Skagit PUD is not required to prevent the account from receiving emails.
3. Mail Servers
- a. Spam Protection
 - i. Spam filters are implemented to reduce the likelihood that employees will click on email links or download malware attachments to their local devices. Skagit PUD will do the following to protect from threats:
 - A. Employ spam protection systems at system entry and exit points to detect and take action on unsolicited messages.
 - B. Update spam protection systems when new releases are available per the configuration change management standard.
 - C. Skagit PUD distinguishes between sending bulk emails and unsolicited emails (spam). Mass emails are acceptable when necessary for both sales and non-sales purposes (such as informing Skagit PUD's staff or clientele, for example). It is completely forbidden to send spam.
 - b. Skagit PUD will filter email at a gateway and/or mail server to remove spam, viruses, or other items that may be:
 - i. against the spirit of this standard; or

- ii. a possible risk to the IT security of the organization. Employees are also urged to be aware of this policy and exercise caution while opening emails.
 - c. Many anti-malware and email programs can recognize and quarantine emails that they find suspicious. The IT Manager may choose to employ this functionality or not. If unsolicited email becomes a problem, Skagit PUD may try to reduce the number of emails the employees receive.
 - d. Email storage may be made available on Skagit PUD's servers or other hardware. The IT department must determine the maximum email account storage size that is reasonable for each employee. Storage restrictions may vary by employee or position.
 - e. Email should be stored and backed up to comply with relevant policies. Email should be treated as operational data for backup and retention unless otherwise stated.
2. Email Security Network and Settings
- a. No employees, personnel, or independent contractors using Skagit PUD facilities should change the security settings in Skagit PUD's email system. Individuals who alter the email security settings without authorization are in violation of this standard.
 - b. Employees cannot upload details on the network or server configuration of any Skagit PUD device to public newsgroups or mailing lists. This includes software version numbers, server names, server types, and internal machine addresses.
 - i. Information received via unencrypted email is never to be thought of as secure or confidential.
 - c. Email retention information (mail messages and attachments) on Skagit PUD's email system will be backed up and retained for 90 days to allow for recovery.

Enforcement and Exceptions

Violations of this standard or failure to implement the procedures of this standard may result in disciplinary action up to and including termination.

The General Manager or the IT Manager is authorized to grant exceptions to the requirements set forth in this standard. Exception requests must be submitted in writing and must include a detailed business case supporting the need for the exception. Any consideration of an exception will require a thorough review of the situation by the IT Manager. An approved exception will require the implementation of appropriate compensating controls.

References:

NIST 800-53 Rev 5: SI-3, SI-8

CIS Controls: 8, 9, 12

Former Title/Policy #:	N/A
Effective Date:	
Revision Date:	
General Manager Signature:	Date:



Identification and Authentication IT Standard #4008

Purpose

Skagit PUD will implement controls to ensure that only properly identified and authenticated users and devices are granted access to information resources in compliance with organizational security policies, standards, and procedures.

Scope

The scope of this standard is applicable to all information resources owned or operated by Skagit PUD. All users, including employees, third-party providers, and contractors, are responsible for adhering to this standard.

Statement of Standard

1. General
 - a. Skagit PUD must have mechanisms in place to verify a person's identity. This will include the use of user IDs and passwords.
 - b. Users are prohibited from asking for another person's user ID or password.
 - c. If any user is concerned that the security of their user ID or password has been compromised, they must report it to the IT department.
 - d. Servers that are mission-critical and/or are used to access or store confidential information must have passwords that conform to the standards identified in this standard.
 - e. User IDs and passwords are deactivated upon an employee's termination.
 - f. Skagit PUD will implement multi-factor authentication based on the risk analysis for the department, applicable system, or applicable organization.
2. User Identifier (User IDs) Management
 - a. User IDs must be unique to each user and should not be reused even after the user no longer has access to information resources.
 - b. Sharing user IDs and passwords is prohibited.
 - i. Exceptions may be made for shared workstations but should be limited to specific business needs. These exceptions will be approved and documented by the IT Manager.
 - c. User IDs are not permitted to be documented, written, or otherwise exposed in an insecure manner.
 - d. User IDs will be disabled after 30 days of inactivity.
3. Password Management
 - a. Skagit PUD requires all users to create, change, and safeguard strong passwords.

- b. Passwords should not be inserted into email messages or other forms of electronic communication.
 - c. Stored passwords must be encrypted.
 - d. Passwords must be hard to guess. Skagit PUD will provide guidance and training to ensure users create strong passwords.
 - e. Users should not circumvent password entry with auto-login, application remembering, embedded scripts, or hard-coded passwords in information systems. Users should always select “no” when asked to have a password “remembered.” This does not apply to the use of PUD-approved password managers.
 - f. Users who forget their password may contact the IT department. The helpdesk technician or server administrator will provide the user with a temporary, one-time-use password that the user must change on first use.
 - g. Skagit PUD will include the use of multi-factor authentication (where possible) and the use of password managers in order to ensure users are creating unique, long, and random passwords for each information system.
 - h. Users must not reuse work-related passwords for personal or other non-work-related purposes (Skagit PUD will provide guidance and training since, technically, this isn't feasible to enforce).
 - i. Where password managers aren't possible, the password policy will require the following: long passwords, using passphrases as passwords, and users must change all passwords at least once a year.
 - j. Devices that arrive with default passwords are required to have the password changed prior to being deployed to the network.
4. Password Guidelines for Creating Strong Passwords:
- a. Passwords unless otherwise specified must contain:
 - i. A minimum of 16 characters.
 - ii. A mix of upper (A-Z) and lowercase (a-z) characters.
 - iii. At least 1 special character (such as !@#\$%^&* \langle \rangle).
 - b. Passwords should contain more than one individual word that is found in any of the following: dictionary, language, dialect, slang, jargon, etc.
 - c. It is acceptable to use passphrases that consist of three words (at a minimum); where non-alphabetic characters are used between each word. The user should use identifiable or meaningful words, so they can remember the passphrase without needing to write it down. A passphrase example might be: "Summer2013#Beach_Party!".
 - d. Passwords should be changed every 180 days.
 - e. The use of common passwords (i.e., 123456, password, qwerty, etc.) is prohibited.

Enforcement and Exceptions

Violations of this standard or failure to implement the procedures of this standard may result in disciplinary action up to and including termination.

The General Manager or the IT Manager is authorized to grant exceptions to the requirements set forth in this standard. Exception requests must be submitted in writing and must include a detailed business case supporting the need for the exception. Any consideration of an exception will require a thorough review of the situation by the IT Manager. An approved exception will require the implementation of appropriate compensating controls.

References:

NIST 800-53 Rev 5: IA-1, IA-2, IA-4, IA-5

CIS Controls: 4, 16

Former Title/Policy #:	N/A
Effective Date:	
Revision Date:	
General Manager Signature:	Date:



Media Protection IT Standard #4009

Purpose

Skagit PUD ensures that sensitive information stored or transported on storage devices and removable media is appropriately controlled and managed. Unless otherwise stated, media includes digital and non-digital media.

Scope

The scope of this standard is applicable to all information resources owned or operated by Skagit PUD. All users, including employees, third-party providers, and contractors, are responsible for adhering to this standard.

Statement of Standard

1. General

- a. Skagit PUD will restrict access to media by implementing technical controls or a written authorization process.
- b. In addition, Skagit PUD will restrict flash drives or external hard drives from being used.
- c. As appropriate, Skagit PUD will label portable, digital media with the classification of the information being stored or transported.
 - i. Authorized personnel should refer to the Information Classification standard to identify how each classification category should be handled, stored, and maintained.
- d. Skagit PUD will maintain an inventory of devices. This inventory will include the following information about each device:
 - i. When a device was onboarded;
 - ii. The name of the device;
 - iii. Where the device lives - and if it moves during its lifecycle, a thorough tracking of its movement;
 - iv. Who is the owner of the device;
 - v. Who is using the device (may be the same as the owner);
 - vi. Contingency planning elements related to the device (e.g., confidentiality, integrity and availability of data on the device, recovery point objectives and recovery time objectives, backup procedures, etc.);
 - vii. When the device is decommissioned;
 - viii. How the device is sanitized prior to disposal.
- e. All media (including the device it's stored on) must be physically controlled by authorized personnel and securely stored when physical control is not feasible.
 - i. Secure storage includes safeguards such as a locked drawer, desk, or cabinet, or a controlled media library.
 - ii. The type of media storage should align with the classification of the information residing on the media.

2. Media Transport

- a. Media being transported must be protected at all times.
 - i. Physical and technical safeguards for media should align with the classification of the information stored on the media.
 - b. Only authorized personnel may transport media. All exceptions must be approved and documented by the IT Manager.
 - c. The following activities must be documented as it relates to the transport of media:
 - i. Media transport authorization;
 - ii. The type of transport;
 - iii. The security safeguards that are put in place;
 - iv. Incidents that may have occurred during transport.
3. Media Sanitization
- a. All media must be sanitized prior to the following events: Disposal, release from organizational control, or release for reuse.
 - b. Media must be sanitized prior to being reused or released for disposal to prevent the disclosure of information to unauthorized individuals.
 - c. Disposal must be in accordance with applicable record retention schedules and data classification.
 - d. Information that will be tracked in relation to sanitization and disposal include the following:
 - i. Name of the device;
 - ii. Type of information that was on the device;
 - iii. Reason for decommission;
 - iv. Sanitization process (including a certificate of destruction if using a third party);
 - v. Disposal process;
 - vi. Date of disposal.

Enforcement and Exceptions

Violations of this standard or failure to implement the procedures of this standard may result in disciplinary action up to and including termination.

The General Manager or the IT Manager is authorized to grant exceptions to the requirements set forth in this standard. Exception requests must be submitted in writing and must include a detailed business case supporting the need for the exception. Any consideration of an exception will require a thorough review of the situation by the IT Manager. An approved exception will require the implementation of appropriate compensating controls.

References:

NIST 800-53 Rev 5: CM-8, MP-1, MP-2, MP-3, MP-4, MP-5, MP-6, MP-7

CIS Controls: 1, 2, 5, 8, 13, 14

Former Title/Policy #:	N/A
Effective Date:	
Revision Date:	
General Manager Signature:	Date:



Risk Assessment and Management IT Standard #4010

Purpose

Skagit PUD will have procedures to facilitate the implementation of the risk assessment policy and associated risk management controls.

Scope

The scope of this standard is applicable to all information resources owned or operated by Skagit PUD. All users, including employees, third-party providers, and contractors, are responsible for adhering to this standard.

Statement of Standard

1. Risk Assessment
 - a. Skagit PUD will conduct a risk assessment of the potential risks and vulnerabilities against all information resources owned or operated by Skagit PUD.
 - b. Conduct risk assessments under the supervision of the IT Manager.
 - c. Risk assessments should be conducted on an annual basis and after significant changes to the environment where information systems operate.
 - d. The assessment should review the effectiveness of existing security controls and safeguards.
 - e. The risk assessment should include a review of the likelihood and impact that a vulnerability could be exploited and its effect on information resources.
 - f. Based on the results of the assessment, create a prioritized corrective action plan to mitigate risks.
2. Vulnerability Assessments
 - a. The IT team will ensure that all network systems, operating systems, and applications undergo vulnerability assessments.
 - b. A vulnerability assessment should be conducted on a quarterly basis or after a significant change occurs in the environment and at other times as needed by current threats.
 - c. The Network Systems Administrator is authorized to conduct network scanning of devices attached to the network. Information gathered from these scans will be used for network management, including:
 - i. Notifying asset owners of vulnerabilities;
 - ii. Determining incorrectly configured systems;
 - iii. Mitigating vulnerabilities identified;
 - iv. Other tasks as needed.
 - d. Owners of information resources found to be vulnerable in any way will be

- contacted regarding identified risks. The resource owner is responsible for ensuring that any identified risk is mitigated in a timely manner.
 - e. If known vulnerabilities are not resolved, access to any affected resource will be disabled from the network.
- 3. Cyber Threat Hunting
 - a. Skagit PUD will implement cyber threat hunting capabilities to proactively search through network resources to detect and isolate advanced threats that have the potential to evade existing security measures.
 - b. Cyber threat hunting will include capabilities to detect, track, and disrupt threats evading existing controls.
- 4. Risk Management
 - a. Risks identified by the risk assessment process and/or discovered during vulnerability assessments will be prioritized based on the potential impact to information resources.
 - b. Security measures/controls must be implemented to minimize risks and vulnerabilities to an appropriate level within the risk tolerance defined at Skagit PUD.
 - i. Document decisions leading to risks being mitigated instead of remediated, or risks falling within an acceptable level of risk tolerance.
 - c. Implemented security measures/controls must be selected based on their effectiveness for minimizing or eliminating risks.
 - d. Security measures will be implemented under the direction of the IT Manager.
 - e. Security measures should be reviewed and revised on a regular basis under the direction of the IT Manager.

Enforcement and Exceptions

Violations of this standard or failure to implement the procedures of this standard may result in disciplinary action up to and including termination.

The General Manager or the IT Manager is authorized to grant exceptions to the requirements set forth in this standard. Exceptions must be submitted in writing and must include a detailed business case supporting the need for the exception. Any consideration of an exception will require a thorough review of the situation by the IT Manager. An approved exception will require the implementation of appropriate compensating controls.

References:

NIST 800-53 Rev 5: RA-1, RA-3, RA-5, RA-7, RA-10
 CIS Controls: 3, 5, 6, 8, 18, 20

Former Title/Policy #:	N/A
Effective Date:	
Revision Date:	
General Manager Signature:	Date:



Security Awareness Training and Testing IT Standard #4011

Purpose

This standard specifies Skagit PUD's internal information security awareness and training program to inform and assess all personnel regarding their information security obligations.

Scope

The scope of this standard is applicable to all information resources owned or operated by Skagit PUD. All users, including employees, third-party providers, and contractors, are responsible for adhering to this standard.

Statement of Standard

1. All awareness training must fulfill the requirements for the security awareness program as listed below
 - a. The information security awareness program should ensure that all personnel achieve and maintain a basic level of understanding of information security matters, at a minimum. This includes, but is not limited to, general obligations under various information security policies, standards, procedures, guidelines, laws, regulations, contractual terms, and generally held standards of ethics and acceptable behavior.
 - b. Additional training is appropriate for personnel with specific obligations towards information security that are not satisfied by basic security awareness. For example, Information Risk and Security Management, Security Administration, Site Security, and IT/Network Operations personnel. Such training requirements must be identified in departmental/personal training plans and funded accordingly. The training requirements will reflect relevant prior experience, training and/or professional qualifications, and anticipated job requirements.
 - c. Security awareness and training activities should commence as soon as possible after an individual joins the organization, generally through attending information security orientation as part of the onboarding process. The awareness activities will continue on a monthly basis thereafter to maintain a reasonably consistent level of awareness.
 - d. Skagit PUD will provide staff with information on the location of the security awareness training materials, along with security policies, standards, and guidance on a wide variety of information security matters.
2. Skagit PUD requires that each employee upon hire and semi-annually thereafter successfully complete cybersecurity training. Some personnel may be required to complete additional training depending on their specific job requirements upon hire

and at least annually. Staff will be given a reasonable amount of time to complete each course to prevent disruption to business operations.

3. The IT department will conduct periodic simulated social engineering exercises including but not limited to: phishing (email), vishing (voice), smishing (SMS), USB testing, and physical assessments. The IT department will conduct these tests at random throughout the year with no set schedule or frequency.
4. Skagit PUD will distribute incident or event-related security advisories to Skagit PUD personnel as appropriate.
5. Security awareness training records will be developed and retained for all personnel.

Enforcement and Exceptions

Violations of this standard or failure to implement the procedures of this standard may result in disciplinary action up to and including termination.

The General Manager or the IT Manager is authorized to grant exceptions to the requirements set forth in this standard. Exception requests must be submitted in writing and must include a detailed business case supporting the need for the exception. Any consideration of an exception will require a thorough review of the situation by the IT Manager. An approved exception will require the implementation of appropriate compensating controls.

References:

NIST 800-53 Rev 5: IR-1, IR-2, IR-3, IR-4, IR-5, IR-6, IR-7, IR-8

CIS Controls: 6, 13, 18, 19, 20

Former Title/Policy #:	N/A
Effective Date:	
Revision Date:	
General Manager Signature:	Date:



Security Incident Response IT Standard #4012

Purpose

Skagit PUD will define a security incident response standard to protect the integrity, availability, or confidential information and minimize the disruption of services used to conduct the District's business. This standard establishes the coordination of the District's response to computerized and electronic communication systems incidents to enable quicker remediation, information gathering, and reporting of infrastructure-affecting and data-compromising events.

Scope

The scope of this standard is applicable to all information resources owned or operated by Skagit PUD. All users, including employees, third-party providers, and contractors, are responsible for adhering to this standard.

Statement of Standard

1. General
 - a. This standard governs the District's general response, documentation, and reporting of incidents affecting computerized and electronic communication information resources.
 - b. Examples of incidents include but are not limited to events such as theft, intrusion, misuse of data, corruption of software, or other activities contrary to the District's Acceptable Use Policy.
 - c. This standard does not include damage to personal or other outside computers unless those computers contribute to the incident as defined below.
2. Definition
 - a. An IT security incident is defined as any activity that harms or represents a serious threat to the whole or part of the District's computer, SCADA, telephone, and network-based resources such that there is an absence of service, inhibition of functioning systems, including unauthorized changes to hardware, firmware, software, or data, unauthorized exposure, change or deletion of information, or a crime or natural disaster that destroys access to or control of these resources.
3. Identification of Incidents
 - a. Any staff may refer an activity or concern to the IT department. The IT department itself can also identify an incident through its proactive monitoring of the District's network and information system activities.
 - b. Once identified, the IT department will use standard internal procedures to log and track incidents and, working with others as appropriate, take steps to investigate, escalate, remediate, refer to others or otherwise address as outlined in the remainder of this standard.
4. Establishment of an IT Security Response Team
 - a. The IT department is responsible for incident interdiction and remediation of computer and electronic communication-based resources affected by these incidents.

- b. The IT department will consult key members of the District and those in the affected areas to establish and IT Security Incident Response Team appropriate to respond to a specific Incident.
5. Risk Assessment Classification Matrix
 - a. The IT department will establish an internal risk assessment classification matrix to focus the response to each incident and to establish the appropriate team participants to respond to.
 - b. The classification matrix will correspond to an "escalation" of contacts across the District and will indicate who to involve and which procedure would be applicable for each class of incident.
6. Documentation and Communication of Incidents
 - a. The IT department will ensure that Incidents are appropriately logged and archived. Incident reporting will be provided by the IT Manager to the General Manager and Safety Manager.
 - b. Wherever possible, documentation of such incidents will cross-reference other events logged in our ticketing and network monitoring systems.
 - c. The IT department or IT Security Incident Response Team representatives will be responsible for communicating the Incident to appropriate District staff and maintaining contact, for the purpose of update and instruction, for the duration of the incident.
7. Other Responsibilities
 - a. The IT department will maintain standard subordinate procedures for the response and investigation of each incident, as well as securing the custody of any evidence obtained in the investigation. The application of these procedures will be governed by the risk assessment classification matrix. The procedures will specify the location and method of custody for each incident if custody of evidence is required.
 - b. District staff are required to report incidents to itsupport@skagitpud.org or to any member of the IT department.
 - c. A response plan or remediation defined by this standard may be preempted as required or at the District's discretion by the intervention of federal and state executive officials.
 - d. Wherever possible, the District will undertake to prevent incidents by monitoring and scanning its own network for anomalies and developing clear protection procedures for the configuration of its IT resources.
 - e. This policy and its procedures will be reviewed at least every two (2) years to adjust processes, identify new risks and remediations.

Enforcement and Exceptions

Violations of this standard or failure to implement the procedures of this standard may result in disciplinary action up to and including termination.

The General Manager or the IT Manager is authorized to grant exceptions to the requirements set forth in this standard. Exception requests must be submitted in writing and must include a detailed business case supporting the need for the exception. Any consideration of an exception will require a thorough review of the situation by the IT Manager. An approved exception will require the implementation of appropriate compensating controls.

References:

NIST 800-53 Rev 5: IR-1, IR-2, IR-3, IR-4, IR-5, IR-6, IR-7, IR-8

CIS Controls: 6, 13, 19, 20

Former Title/Policy #:	N/A
Effective Date:	
Revision Date:	
General Manager Signature:	Date:



System Integrity and Vulnerability Management IT Standard #4013

Purpose

The purpose of this standard is to facilitate the implementation of system and information integrity controls. This standard will also ensure and maintain the confidentiality, integrity, and availability of Skagit PUD systems and the data transmitted, processed, received, and/or stored on Skagit PUD's systems in compliance with all security policies, standards, and procedures.

Scope

The scope of this standard is applicable to all information resources owned or operated by Skagit PUD. All users, including employees, third-party providers, and contractors, are responsible for adhering to this standard.

Statement of Standard

1. Flaw Remediation

a. Skagit PUD will:

- i. Ensure the IT department with the help of Qualys Vulnerability Management and CrowdStrike Falcon Complete is used to identify, report, and correct system flaws.
- ii. Ensure the IT department will test software and firmware updates related to flaw remediation for effectiveness and potential side effects before installation.
- iii. Install security-relevant software and firmware updates within a week of the release of the update.
- iv. Incorporate flaw remediation into the configuration management standard.
- v. Skagit PUD will review system components on a weekly basis to determine if system components have applicable security-relevant software and firmware updates installed using Qualys Vulnerability Management tool.

2. System Monitoring

a. Skagit PUD will continuously monitor the system to:

- i. Ensure attacks and indicators of potential attacks are detected.
- ii. Ensure detection of unauthorized local, network, and remote connections.
- iii. Identify unauthorized use of the system through endpoint and detection response.

- iv. Deploy internal monitoring capabilities or monitoring devices within the system to collect network traffic logs of interest to Skagit PUD.
 - v. Analyze detected events and anomalies, within an hour.
 - vi. Adjust the level of system monitoring activity when there is a change in risk to organizational operations and assets, individuals, or based on intelligence from CISA, the FBI, and CrowdStrike.
 - vii. A process will be implemented to ensure that the IT department is aware of and responsible for system monitoring information.
 - viii. The organization employs monitoring tools to support near real-time analysis of events.
 - ix. The information system monitors inbound and outbound communications traffic for unusual or unauthorized activities or conditions.
 - x. System alerts will be sent to IT system administrators when indications of compromise or potential compromise, such as alerts from an intrusion detection or prevention system occur.
3. System-generated & Security Alerts, Advisories, and Directives
- a. Skagit PUD will ensure that:
 - i. System alerts, advisories, and directives are generated from inputs from malicious code protection systems, intrusion detection or prevention systems, or devices such as firewalls, gateways, and routers and distributed to the IT department that will take appropriate action when alerts occur.
 - ii. Alerts are transmitted through email, or SMS as required.
 - iii. Security directives are reviewed within a week of publication and the IT department will be responsible for implementing directives as they relate to Skagit PUD. If Skagit PUD chooses not to implement the security direction, Skagit PUD will document the reason, or degree of, noncompliance.
4. Software, Firmware, and Information Integrity
- a. Skagit PUD will:
 - i. Employ CrowdStrike and Claroty to detect unauthorized changes to software, firmware, and information, such as operating systems, BIOS, and metadata.
 - ii. Perform an integrity check of software, firmware, and information at startup, and/or at security events, such as detected errors or malicious code detection. Integrity checking should also be proactively performed weekly.
 - iii. Incorporate the detection of unauthorized changes to the system into the incident response plan or procedures.
5. Information Input Validation
- a. Skagit PUD will:
 - i. Ensure the system checks the validity of character set or acceptable values, and verify inputs match Skagit PUD's definitions for format and content.

- ii. Ensure the system has a manual override function for input validation of character set or acceptable values, restricts the use of the manual override capability to only IT system administrators and ensures audits are regularly conducted on the use of the manual override function.
 - iii. Skagit PUD reviews and resolves input validation errors within a 72-hour period or immediately.
 - iv. Ensure the system behaves in a predictable and documented manner, this includes rejecting invalid data that reflects system objectives when invalid inputs are received to avoid adverse, unintended side effects.
 - v. Address and review for timing interactions among system components in determining rejecting invalid data for invalid inputs.
 - vi. The organization restricts the use of information inputs to whitelisted sources and/or information in an expected length or size or numeric range.
6. Error Handling
- a. Skagit PUD will ensure the system:
 - i. Generates error messages that provide the necessary information for corrective actions without revealing information that could be exploited.
 - ii. Reveals error messages only to IT system administrators and/or application owners.
7. Information Management and Retention
- a. Skagit PUD will:
 - i. Manage and retain information within the system and information output from the system in accordance with state/federal laws, policies, regulations, standards, etc.
8. Memory Protection
- a. Skagit PUD will:
 - i. Ensure the system implements data execution prevention to protect from unauthorized code execution.

Enforcement and Exceptions

Violations of this standard or failure to implement the procedures of this standard may result in disciplinary action up to and including termination.

The General Manager or the IT Manager is authorized to grant exceptions to the requirements set forth in this standard. Exception requests must be submitted in writing and must include a detailed business case supporting the need for the exception. Any consideration of an exception will require a thorough review of the situation by the IT Manager. An approved exception will require the implementation of appropriate compensating controls.

References:

NIST 800-53 Rev 5: SI-1, SI-2 (2), SI-3, SI-4 (2) (4) (5), SI-5, SI-7 (1) (7), SI-10, SI-11, SI-12, SI-16

CIS Controls: 3, 4, 6, 8, 11, 16, 18, 19, 20

Former Title/Policy #:	N/A
Effective Date:	
Revision Date:	
General Manager Signature:	Date:



System Maintenance IT Standard #4014

Purpose

Skagit PUD will use this standard to establish a process for maintaining organization-owned hardware and software. Proper maintenance and support of these assets increases usability and lowers the total cost of ownership to the organization. This policy is designed to support preventative and ongoing maintenance of Skagit PUD's computer and software assets.

Scope

The scope of this standard is applicable to all information resources owned or operated by Skagit PUD. All users, including employees, third-party providers, and contractors, are responsible for adhering to this standard.

Statement of Standard

1. Skagit PUD will review manufacturer and/or vendor specifications and align maintenance guidelines with Skagit PUD requirements. Skagit PUD will implement procedures to schedule, document, and review records of maintenance, repairs, and replacements of system components to meet these objectives.
2. Maintenance personnel:
 - a. Skagit PUD will maintain a list of authorized maintenance partners and personnel who can perform maintenance on all assets. The list of approved maintenance partners and personnel will be reviewed by the IT Manager. These reviews will occur on a quarterly basis or at any time deemed necessary, such as when the environment changes.
 - b. Maintenance partners requiring access to network closets, data centers and/or other areas of the facility that contain sensitive information should be escorted by an authorized member of the IT department, unless the IT Manager has authorized unescorted access.
3. Skagit PUD will maintain an appropriate supply of spare parts for network and server equipment.
 - a. Service-level agreements (SLAs) will be in place to assist with obtaining maintenance support and equipment when maintenance cannot be completed by Skagit PUD authorized personnel. SLAs should contain language to ensure support and/or spare parts are obtained within 48 hours of a system component failure.

4. The IT department will approve and monitor all maintenance activities, whether performed on site or remotely.
5. Skagit PUD will check all systems and system components after all maintenance activity to ensure that security controls are still functioning properly.
6. Skagit PUD will keep a system maintenance record to document all maintenance, repair, and replacement activity. Maintenance records should include the following:
 - a. Asset number.
 - b. Maintenance dates and times.
 - c. Equipment maintenance detail.
 - d. New parts added.
 - e. Manufacturer's recommendations for maintenance.
 - f. Amount of use.
 - g. Equipment environment conditions.
 - h. User experience and knowledge.
7. The IT Manager is responsible for approving, controlling, and monitoring the use of approved system maintenance tools.
8. Approved system maintenance tools will be reviewed by IT system administrators. These reviews will occur on a quarterly basis or at any time deemed necessary, such as when the environment changes.
9. Off-site maintenance:
 - a. The IT Manager must explicitly approve, in writing, the removal of a system or system component for off-site maintenance, repair, or replacement.
 - i. All systems and/or components will be sanitized prior to removing from Skagit PUD facilities for off-site maintenance, repair, or replacement. Sanitization guidelines from Skagit PUD's Media Protection standard should be followed prior to releasing the component for maintenance.
 - b. The IT Manager will approve and monitor all maintenance and diagnostic activities performed off-site.
 - c. Skagit PUD allows the use of maintenance and diagnostic tools by off-site vendors only as consistent with organizational policy and documented in the security plan for the system.
 - i. Skagit PUD will restrict or prohibit off-site maintenance to trusted maintenance facilities as authorized by the IT Manager.
 - d. Skagit PUD requires that all remote and/or off-site maintenance and diagnostic sessions use strong authentication measures.
 - e. Skagit PUD will maintain records of all remote and/or off-site maintenance and diagnostic activities.
 - f. Skagit PUD will implement technical controls to terminate sessions and network connections when remote and/or off-site maintenance is complete.

Enforcement and Exceptions

Violations of this standard or failure to implement the procedures of this standard may result in disciplinary action up to and including termination.

The General Manager or the IT Manager is authorized to grant exceptions to the requirements set forth in this standard. Exceptions must be submitted in writing and must include a detailed business case supporting the need for the exception. Any consideration of an exception will require a thorough review of the situation by the IT Manager. An approved exception will require the implementation of appropriate compensating controls.

References:

NIST 800-53 Rev 5: MA-1, MA-2, MA-3, MA-4, MA-5, MA-6, MA-7

CIS Controls : 2, 5, 6, 8, 11, 14

Former Title/Policy #:	N/A
Effective Date:	
Revision Date:	
General Manager Signature:	Date:



1415 Freeway Drive | Mount Vernon, Washington 98273 | (360) 424-7104 | SkagitPUD.org

May 28, 2024

MEMORANDUM

TO: George Sidhu, P.E., General Manager
FROM: Mark Handzlik, P.E., Engineering Manager
SUBJECT: Mount Vernon High School Energy Recovery Demonstration Project - *Action*

Requested Action:

Authorize the general manager to sign the interlocal agreement with the Mount Vernon School District for the Mount Vernon High School Energy Recovery Demonstration project and sign agreements with InPipe Energy, the Department of Commerce, and Trans Alta for the funding, design, construction of the project.

Background:

Skagit PUD has received 100% grant funding to install an Energy Recovery Unit (ERU) Demonstration project at the 9th and Highland tank site, where 56 kW of power could be recovered from the excess pressure in the existing water supply line. Skagit PUD does not have a need for this amount of power on-site and is considering an arrangement to allow the excess net metering credit to go to the adjacent Mount Vernon High School, which has a sufficient demand to consume the balance of the energy.

Skagit PUD and Mount Vernon School District have now established a final scope for the project and the roles and responsibilities of each party. Under the current framework, the PUD will design, build, and maintain the ERU and two electrical vehicle charging stations on its property. The Mount Vernon School District will take responsibility for and place its name on the two electrical meters serving the PUD's property at 9th and Highland. These two services and the net meter will be included in the Mount Vernon High School suite of meters. Any consumptive energy recovered over and above that consumed by the PUD will offset consumption at Mount Vernon High School.

To complete the launch of this project the PUD must sign the inter-local agreement with the school district (final attached), authorizing the general manager to accept a Washington State Department of Commerce grant of \$598,800 and a Trans Alta Coal Transition grant in the amount of \$240,000 (final agreements attached), and authorizing the General Manager to enter into a contract with InPipe Energy (agreement attached) for the supply and installation of the ERU. The selection of the contractor is based on the attached sole source purchasing form (final draft attached).

The final, signature-ready, drafts of these documents are attached to this request.

Fiscal Impact:

This project is listed in the approved 2024 capital budget under line item MX13-3 showing an estimated project cost of \$800,000 and potential grant funding of \$1,000,000. The final construction estimate is \$950,000. Funding for the design and construction of this project will come from \$598,800 in Clean Energy grant funds, \$240,000 in Trans Alta Coal Transition grant funds, and the remaining \$111,200 will come from IRS credits or additional grants.

- Enclosures:
1. Trans Alta Skagit PUD - Grant Agreement
 2. InPipe Sole Source
 3. PUD InPipe Energy Contract
 4. 24-5-15 School Interlocal Final REV
 5. 24-92201-032 - Interagency Agreement

TRANSALTA CENTRALIA BOARD FUNDING, LLC
Energy Technology Fund
GRANT AGREEMENT

This Grant Agreement (the “Grant Agreement”) is entered between TransAlta Centralia Board Funding, LLC, acting through its Energy Technology Board (“Grantor”), and Skagit PUD No. 1 (“Grantee”) to establish the terms and conditions of a grant of funds from Grantor to Grantee to support the Mount Vernon High School Energy Recovery Project. In consideration of the mutual covenants, conditions, and agreements that follow, the parties hereby agree:

1. *Grant.* Grantee will receive the sum of \$240,000.00 subject to all the terms and conditions of this Grant Agreement.
2. *Disbursement Schedule.* The grant funds will be paid to Grantee in accordance with the disbursement schedule set forth on Exhibit A to this Grant Agreement, provided that Grantee returns a countersigned original of this Grant Agreement prior the date of the first such disbursement.
3. *Grant Activities; Budget.* Grantor agrees to perform the activities described in its grant proposal as finally accepted, a copy of which is attached to this Grant Agreement as Exhibit B (the “Grant Proposal”). Grantor approves the budget included in the Grantee’s Grant Proposal.
4. *General Conditions.* Attached as Exhibit C to this Grant Agreement are the TransAlta Centralia Board Funding, LLC Grant Terms and Conditions. Grantee acknowledges that it has read the TransAlta Grant Terms and Conditions and agrees to comply with them.
5. *Grantee Reports.* Grantee agrees to provide to Grantor the narrative reports and financial reports in accordance with paragraph 6 of the Grant Terms and Conditions. Such reports shall be in the form set forth on Exhibit D to this Grant Agreement.
6. *Special Conditions.* The award of the Grant is subject to the additional conditions and agreements between Grantor and Grantee that are set forth on Exhibit E to this Grant Agreement.
7. *Term; Grant Period.* This Grant Agreement shall be effective upon signature by Grantor and Grantee and shall expire December 31, 2024, unless extended by mutual consent or terminated earlier in accordance with this Grant Agreement (the “Grant Period”). Any funds not expended as of the

end of the Grant Period shall be returned to Grantor unless permission has been obtained from Grantor.

- 8. *Governing Law.* This Grant Agreement shall be governed by and construed in accordance with the laws of the State of Washington, without reference to its conflict of laws provisions. Grantor and Grantee agree that any disputes or proceedings arising from or concerning this Grant Agreement shall be brought in a federal or state court of competent jurisdiction sitting in the Western District of Washington, in the United States, and hereby consents to the personal jurisdiction and venue of such courts.

- 9. *Entire Agreement.* Grantee acknowledges and agrees that this Grant Agreement and the exhibits hereto (all of which are incorporated herein by reference and made a part of this Grant Agreement) represent the entire agreement between Grantee and Grantor with respect to the subject matter addressed herein. The terms of this Grant Agreement may be modified only by a writing signed by duly authorized representatives of both parties.

Accepted by:

Skagit PUD No. 1

Date

Date

Approved by:

Energy Technology Board of TransAlta Centralia Board Funding, LLC

Board Member

Date

Board Member

Date

EXHIBIT A

DISBURSEMENT SCHEDULE

Date	Disbursement Amount	Conditions (if any)
TBD	\$240,000.00	subject to paragraph 2 of this agreement subject to the Grantee receiving additional funding to complete the project

EXHIBIT B

ACCEPTED GRANT PROPOSAL

See attached.

EXHIBIT C

TRANSALTA CENTRALIA BOARD FUNDING, LLC GRANT TERMS AND CONDITIONS

The following are the general terms and conditions of grants by TransAlta Centralia Board Funding, LLC, acting through its Grant Review Boards (the "Grantor"):

1. REPRESENTATIONS AND WARRANTIES OF GRANTEE. By executing and delivering the Grant Agreement, Grantee represents and warrants to Grantor as follows:
 - a. Grantee has the requisite legal authority and power to execute and deliver and to carry out the terms of the Grant Agreement.
 - b. To the knowledge of Grantee, the statements made by Grantee in the Grant Proposal (other than forward-looking statements related to the proposed project and application of grant proceeds) are true and correct in all material respects.
 - c. Grantee understands that there is no correlation or connection between Grantor's award of grants and Grantee's business relationship or potential business relationship with Grantor or its affiliates. Participation in Grantor's grant program does not require or impose any *quid pro quo* condition. If Grantee believes that a *quid pro quo* condition exists or may exist, it shall contact Lori Schmitt, c/o TransAlta Centralia Board Funding, LLC, 913 Big Hanaford Road, Centralia, Washington, 98531 to report the condition.
2. REPRESENTATIONS AND WARRANTIES OF GRANTOR. By executing and delivering the Grant Agreement, Grantor represents and warrants to Grantee as follows:
 - a. Grantor has the requisite legal authority and power to execute and deliver and to carry out the terms of the Grant Agreement.
 - b. There is no correlation or connection between Grantor's award of grants and the Grantee's business relationship or potential business relationship with Grantor or its affiliates. Participation in Grantor's grant program does not require or impose any *quid pro quo* condition.
3. FUND DISTRIBUTION. Funds awarded will be distributed in accordance with the disbursement schedule attached as Exhibit A to the Grant Agreement.
4. BUDGET REVISION. Grant funds shall be used as set forth in the budget included in the final grant proposal, attached as Exhibit B to the Grant Agreement (the "Grant").

Proposal”). Any transfer of funds from one budget item to another that exceeds 10% of the approved budget item requires Grantor’s prior written consent.

5. NO COST EXTENSION. If needed, Grantee may submit a request for a no-cost extension to Grantor before the end of the Grant Period. The request should contain the reason for the extension, any unexpended funds identified and how the funds will be used, and the length of time requested for the extension. Grantor may in its sole discretion approve or deny such request for an extension, and if such extension is approved, then the Grant Period (as such term is defined in the Grant Agreement) shall be accordingly extended.
6. GRANTEE REPORTS. Grantees must submit periodic reports to Grantor.
 - a. Narrative Report. A quarterly narrative report concerning the nature and use of funds awarded pursuant to this grant is to be submitted in the format set forth on Exhibit D to the Grant Agreement, unless otherwise specified in the Grant Agreement. The quarterly reporting periods shall commence the first quarter following the date of signing the Grant Agreement. Grant periods will be March 30, June 30, September 30, and December 30. A final report shall be due within 30 days of the completion of the project. In the event there is a change in the project schedule the Grantee shall provide a report to the Grantor outlining the schedule and the reason for delay.
 - b. Financial Reports. Quarterly financial reports consisting of an unaudited balance sheet and unaudited statements of income and cash flows for the quarter then ended shall be submitted by Grantee in the format set forth on Exhibit D to the Grant Agreement within 30 days for the quarter then ended. The Grantor may request audited financial statements from the Grantee.
7. REPORTING REQUIREMENT; WAIVER. Failure to submit reports required under paragraphs 6 or 7 of these Grant Terms and Conditions in a manner satisfactory to Grantor on a timely basis may result in delay or loss of funds. Under exceptional circumstances, a waiver of Grantor’s obligation to submit such may be available. A written request to waive this requirement must be made to Grantor on or before the end of the period covered by such reporting requirement.
8. GRANT EVALUATION. Grant performance will be evaluated during the year for which the grant is made. The information received in the reports described in paragraphs 6 or 7 of these Grant Terms and Conditions and any Special Conditions required in the Grant Agreement, and, at the discretion of Grantor, from other sources, will form the basis for the report. Grantees must provide further information if requested by Grantor.

9. RECORDS; RIGHT TO INSPECT. Original receipts and invoices must be maintained by Grantee. Grantee agrees to maintain adequate financial records consistent with generally accepted accounting practices, and to retain such records for at least five years after the conclusion of the Grant Period. Grantor staff and trustees may review Grantee's data, records, or materials relating to the administration and performance of a grant at any time on five (5) business days' notice. Grantee will not be required to produce data, records, or materials that would be confidential information under the attorney-client privilege or work product doctrine.
10. TERMINATION. Grantor has the right to terminate the Grant Agreement at any time that it determines that any of the following events has occurred:
- a. such funds have not been or will not be expended reasonably or prudently for the purposes specified in the Grant Agreement;
 - b. Grantee has violated any federal, state, or local law or regulation;
 - c. Grantee has failed to fully comply with these Grant Terms and Conditions and the Grant Agreement, including an unapproved deviation from the Grant Proposal, in either case only if such breach has not been cured within 30 days of Grantor providing Grantee written notice of such breach; or
 - d. Grantor has insufficient funds available for distribution.

In the event the Grant Agreement is terminated under clauses (a), (b) or (c) of this Section 10, Grantor reserves the right to require Grantee to refund any and all grant funds awarded to Grantee under the Grant Agreement, and Grantee agrees to refund Grantor all such funds upon request.

11. UNUSED FUNDS. At the conclusion of the Grant Period, Grantee agrees to return any unexpended or unaccounted for funds to Grantor, or to submit a written request for an extension of the Grant Period. Grantee agrees to return all disbursed funds (1) if grant funds have not been used for their intended purpose, or (2) if grant funds have been used inconsistently with the terms of the Grant Agreement or these Grant Terms and Conditions, or (3) if the activities or outputs set forth in the Grant Proposal are materially incomplete by the end of the Grant Period, as determined by Grantor in its sole discretion.
12. NO LOBBYING. Grantee confirms that the grant funds will not be used for the purposes of lobbying, carrying on propaganda, or otherwise attempting to influence legislation. If Grantee is in doubt about whether its proposed activities may constitute lobbying, Grantee must consult with Grantor prior to undertaking them.

13. LIABILITY INSURANCE. Grantee shall maintain commercial liability insurance that protects Grantee and its officers, agents, and employees from any and all claims, demands, actions, and suits for damage to property or personal injury, including death, arising from Grantee's work under the Grant Agreement. The insurance shall provide coverage for not less than \$2,000,000 per occurrence. If the insurance is canceled or terminated prior to completion of the Grant Agreement, Grantee shall provide a new policy with the same terms. Grantee agrees to maintain continuous, uninterrupted coverage for the Grant Period. The insurance shall include coverage for any damages or injuries arising out of the use of automobiles or other motor vehicles by Grantee.
14. USE OF NAME. Grantee shall acquire prior written consent from Grantor for any use of the TransAlta name or logo in association with its project or the grant.
15. PUBLICITY. Grantee will notify Grantor of any publications or other materials resulting from the grant no later than five (5) days in advance of distribution or publication. Grantee will acknowledge Grantor's support in the beginning of any publication (including film and electronic publications) referring to or resulting from this grant, as follows: "Supported [in part] by a grant from TransAlta Centralia Generation LLC." Grantee agrees that Grantor may include information about Grantee and its activities in its own annual reports and may distribute such information to third parties.
16. FUTURE FUNDING. This grant of funds implies no agreement of any kind by Grantor to grant additional or future funds to Grantee.
17. NO GRANTOR RESPONSIBILITY FOR GRANTEE OBLIGATIONS. Nothing in the Grant Agreement shall be deemed to authorize Grantee to enter any contract, lease, or other agreement on behalf of Grantor. All obligations undertaken by Grantee pursuant to the Grant Agreement shall be on its own behalf. Grantor shall have no responsibility to third parties in connection with the Grant Agreement.
18. INDEMNITY. Grantee shall and hereby does indemnify and hold Grantor, TransAlta Centralia Generation LLC, their affiliates, and their respective employees, officers, agents and representatives (together, the "Indemnitees") free and harmless from liability from any and all suits, claims, demands, losses, damages, actions or judgments of every kind and description (including attorneys' fees and other costs of defense) arising out of the funds granted hereunder, including Grantee's use or administration of the funds, or suffered by the Indemnitees, directly or indirectly, on account of actions or omissions by Grantee in the performance of its obligations hereunder or otherwise.
19. LIMITATION OF LIABILITY. IN NO EVENT, SHALL GRANTOR BE LIABLE FOR ANY INDIRECT, SPECIAL, INCIDENTAL, OR CONSEQUENTIAL DAMAGES OR EXPENSES FOR

ANY NEGLIGENCE, BREACH OF CONTRACT, OR ANY OTHER ACT ARISING OUT OF OR RELATING TO THIS AGREEMENT OR THE ACTIVITIES COVERED HEREIN.

20. AMENDMENTS; WAIVERS. Amendments to the Grant Agreement must be in writing and signed by both parties. No waiver by either party or any breach, default, or series of breaches or defaults, and no failure, refusal, or neglect of either party to exercise any right, power, or option given to it under the Grant Agreement or to insist upon strict compliance with the terms of the Grant Agreement shall constitute a waiver of these provisions with respect to any subsequent breach or waiver by either party or its right at any time thereafter to require exact and strict compliance with provisions of the Grant Agreement.
21. NO ASSIGNMENT. Grantee may not assign the Grant Agreement or delegate performance of the terms of the Grant Agreement or of the project to any other person or entity without Grantor's prior written consent.

EXHIBIT D

FORMS OF GRANTEE REPORTS

As prepared by Grantee and accepted by Grantor.

EXHIBIT E

SPECIAL CONDITIONS AND AGREEMENTS

There are no other special conditions and agreements except as otherwise specified in this Grant Agreement and Exhibits A - D hereof.

PUBLIC UTILITY DISTRICT NO. 1 OF SKAGIT COUNTY

Sole Source Justification Form

Vendor Name: InPipe Energy
Address: 220 Northwest 8th Avenue
City, State, Zip Portland, OR 97209
Phone Number: 1-503-341-0004
Contact Person: Gregg Semler, President and CEO

1. Description of Item (be specific including part number, quantity, quality, type desired, proposed delivery date and any other significant terms of the purchase).

Turnkey Hydro XS pressure reducing energy recovery valve, net metering switchgear, SCADA interface, electrical panel, bypass piping, electrical vehicle charging stations on School District property.

2. This vendor is a sole source because:
- sole provider of items that are compatible with existing equipment, inventory, systems, programs or services
 - sole provider of goods and services for which the District has established a standard (i.e., brand or manufacturer)
 - sole provider of factory-authorized warranty service
 - sole provider of goods or service that will meet the specialized needs of the District or perform an intended function
 - sole provider of a licensed or patented good or service
 - other (provide explanation):

InPipe Energy was specifically named in the grant application without which there would be no funding for this project. The PUD has one other energy recovery unit that was installed by InPipe Energy. The PUD does not anticipate many more of the these devices and would like to remain with one vendor so the PUD can maintain familiarity with the one brand for maintenance and purchasing of parts and supplies.

	chargers.
7	<p>Partnerships and Collaboration (Mandatory, Scored) (5 pts) List partnerships with community groups serving rural or vulnerable communities, tribes, universities, local governments, and/or state or federal agencies. What roles do the partners have in the project? How will they be compensated for their work? Share any Memoranda of Understanding (MOU) from partners. Commerce will contact the partner/writer of each MOU to confirm that they had the opportunity to review and approve the final CEF application before it was submitted. If the partner did not provide consent to submit the application, and it was not reviewed and approved by the MOU writer/partner, the application may be disqualified.</p> <p>The project involves partnership and collaboration between multiple parties, including Skagit PUD, the Mt. Vernon School District and InPipe Energy, a WA contractor and small business that specializes in energy recovery systems in water infrastructure. Senior management of these organizations are in support of the project. No MOUs are in place. Letters of support have been provided.</p>
8	Building on Existing Strengths in Washington (Mandatory, Scored) (5 pts)

Excerpt from Clean Energy Fund (CEF) 5 Rural Clean Energy Program Application

3. What necessary features does this vendor provide which are not available from other vendors? (be specific)

Funding for the project and permitting. Continuity with other equipment that is already installed and under the PUD's maintenance and operation.

4. What steps were taken to verify that these features are not available elsewhere? (list names and phone numbers of other vendors and explain why they were not suitable)

The funding application was prepared by the vendor. No other entities have provided or facilitated 100% project funding.

This is a direct contract with the manufacturer, no other entities carry this brand of product.

Statement of Requestor

My department's recommendation for sole source is based upon an objective review of the goods/services being required and appears to be in the best interest of the District. I know of no conflict of interest on my part or personal involvement in any way with this request. No gratuities, favor or compromising action have taken place. Neither has my personal familiarity with particular brands, types of equipment, materials or firms been a deciding influence on my request to sole source this purchase when other suppliers are known to exist.



Signature of Requestor

April 17, 2024

Date

Finance Manager

Date

General Manager Approval

Approved

Denied

George Sidhu, P.E., General Manager

Date

PUBLIC WORKS CONTRACT

Contract # CONTRACT - 2024 - 000466
Job Identity # cp5068-3796

THIS CONTRACT is made and entered into by and between the PUBLIC UTILITY DISTRICT NO. 1 OF SKAGIT COUNTY (DISTRICT) and INPIPE ENERGY INCORPORATED (VENDOR).

WITNESSETH:

WHEREAS, the District has caused the preparation of certain Contract Documents entitled Mount Vernon High School Energy Recovery Project.

WHEREAS, the District has invited proposals, has received and analyzed said proposals, and has duly given notice of Acceptance of Proposal to the Vendor which are made a part hereof and which constitute the whole Contract between the District and the Vendor.

NOW, THEREFORE, it is hereby agreed that:

1. The Vendor shall furnish the work, pay all costs, and perform all requirements of this Contract in the manner specified in the documents referenced above, and;
2. The Bid or Proposal calls for unit prices and lump sums, or time and material pricing if required, as set forth in #1 above. Vendor will not exceed price without District written approval. The District shall pay to the Vendor a corrected total contract amount computed from the unit prices and lump sums in said Bid or Proposal and the actual quantities of units furnished. Based upon the lump sum and unit prices in said Bid or Proposal, and upon the quantities estimated from the Contract Drawings for bidding purposes, the estimated Total Contract Amount is \$950,000.00,
Nine Hundred Fifty Thousand Dollars and Zero Cents ,
and;
3. In Washington State, the District is required to pay state or local sales or use taxes included in the Total Contract Amount and the Vendor is required to receive the said taxes for payment to the state, the amount payable to the Vendor by the Owner shall be the Total Contract Amount as above specified including the amount of the said taxes. Invoices will be paid by the District to the Vendor within 30 days of receipt based on actual quantities of work performed, and;
4. It is further agreed that the Vendor will start work within ten (10) calendar days after the date specified in the District's Notice to Proceed and shall be substantially complete within 250 calendar days from the date of Notice to Proceed is issued, and;
5. The attached Indemnification Agreement is hereby made part of this Contract, and;
6. In the event that the Vendor fails to substantially complete the Project by the date of substantial completion as specified above or as modified by Change Order, the Vendor shall be liable for liquidated damages of \$0.00

per calendar days thereafter until the District determines the Project to be substantially complete.

IN WITNESS WHEREOF, this Contract, and properly transmitted copies which shall, for all purposes, be deemed an original hereof, have been duly executed by the parties hereto.

INPIPE ENERGY INCORPORATED

PUBLIC UTILITY DISTRICT NO. 1
OF SKAGIT COUNTY

Gregg Semler

Gregg Semler President/CEO
920 SW 6th Ave, 12th Floor
Portland OR 97204

1415 FREEWAY DRIVE
MOUNT VERNON, WA 98273

Date: May 9, 2024

Date: _____

INDEMNIFICATION AGREEMENT

The Vendor agrees to defend, indemnify, and hold the District harmless from any and all claims, demands, losses, and liabilities to or by third parties arising from, resulting from, or connected with work performed or to be performed under this Contract by the Vendor, its agents, employees, and subconsultants, even though such claims may prove to be false, groundless, or fraudulent, to the fullest extent permitted by law and subject to the limitations provided below.

The Vendor's duty to indemnify the District shall not apply to liability for damages arising out of bodily injury to persons or damage to property caused by or resulting from the sole negligence of the District or the District's agents or employees. The Vendor's duty to indemnify the District for liability for damages arising out of bodily injury to persons or damage to property caused by or resulting from the concurrent negligence of Vendor, its agents, employees, or subconsultants and/or the District or the District's agents or employees, shall apply only to the extent of negligence of Vendor, its agents, employees, or subconsultants.

With respect to claims against Vendor by the District pursuant to this Contract only, Vendor expressly waives any immunity that may be granted it under the Workers' Compensation, Industrial Insurance or like statutes and/or any administrative regulations issued pursuant thereto. This waiver does not include or extend to any claims by Vendor's employees directly against Vendor.

Further, Vendor's defense and indemnification obligations under this Contract shall not be limited in any way by any limitation on the amount or type of damages, compensation or benefits payable to or for any third party under Workers' Compensation, Industrial Insurance or like statutes and/or any administrative regulations issued pursuant thereto.

Vendor 's duty to indemnify the District for liabilities or losses, other than for bodily injury to persons or damage to property caused by or resulting from negligence, shall apply only to the extent of the fault of Vendor, its agents, employees, or subconsultants, except in situations where fault is not a requirement for liability, in which case indemnity will be provided to the extent the liability or loss was caused by Vendor or its agents, employees, or subconsultants.

Vendor's duty to defend, indemnify and hold the District harmless shall include, as to all claims, demands, losses and liabilities to which it applies, the District's actual attorneys' fees and costs incurred in connection with defending such claim(s) including, without limitation, consultant and expert witness fees and expenses and personnel-related costs in addition to costs otherwise recoverable by statute or court rule.

THE UNDERSIGNED HEREBY CERTIFY THAT THIS AGREEMENT WAS MUTUALLY NEGOTIATED.

INPIPE ENERGY INCORPORATED

**PUBLIC UTILITY DISTRICT NO. 1
OF SKAGIT COUNTY, WASHINGTON**

By: Gregg Semler
Gregg Semler President/CEO

By: _____

Dated: May 9, 2024

Dated: _____

The Vendor shall cause each of its subconsultants (and suppliers to the extent any perform any work on the Project site) to execute an Indemnification Contract substantially in the form of the foregoing by which each such entity or person assumes to the District all obligations Vendor assumes to the District as set forth above.

Project approach

Installation of the HydroXS System includes three components: the HydroXS, a Control Panel and a Power Distribution Panel. The power generation system will be rated for 56 kW.

Project scope:

- Final design
- Regulatory: application for a FERC exemption
- Installation of a by-pass
- Installation of the HydroXS assembly, valves and piping
- Installation of the HydroXS control panel
- Connection to the site meter specified by Skagit PUD from the HydroXS power distribution panel and all other necessary wiring connections
- Apply and manage net metering application.
- Provide site specific plans, including one-line (electrical) and panel
- Start-up and commissioning

The figure below shows an indicative design for the HydroXS

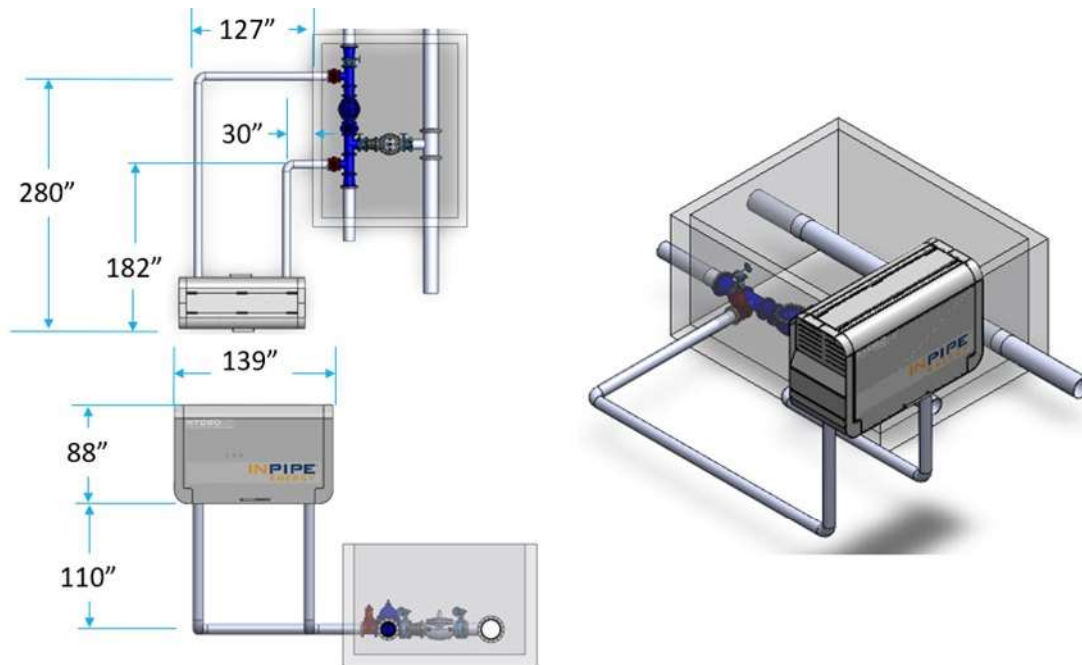

Product features, capabilities and sub-systems include:

- A hydro turbine with UL-tested induction generator
- PRV valves with electronic solenoid control and pressure transmitter
- A self-contained custom control panel (controllers, relays, ancillary PFCCs and a PCL system) that can be connected to an existing SCADA communication
- Manual isolation valves, visual position indicators
- Constant flow monitoring (+/- 2% accuracy, NIST traceable)

- Automated alarms for flow interruptions, safety measures, and maintenance checks
- Programmable logic controller (PLC) processors, which consolidate control of the HydroXS unit
- Automated safe shutoff and restart adhering to IEEE 1574

The installation will comply with all rules governing electric utility parallel interconnection, including power outage protection and auto shut off and restart. The HydroXS has a single microprocessor multifunction relay and the main trip functions are backed up with a dissimilar yet equal trip function.

PROJECT SCHEDULE

The project schedule, including key milestones, is summarized in the figure below:

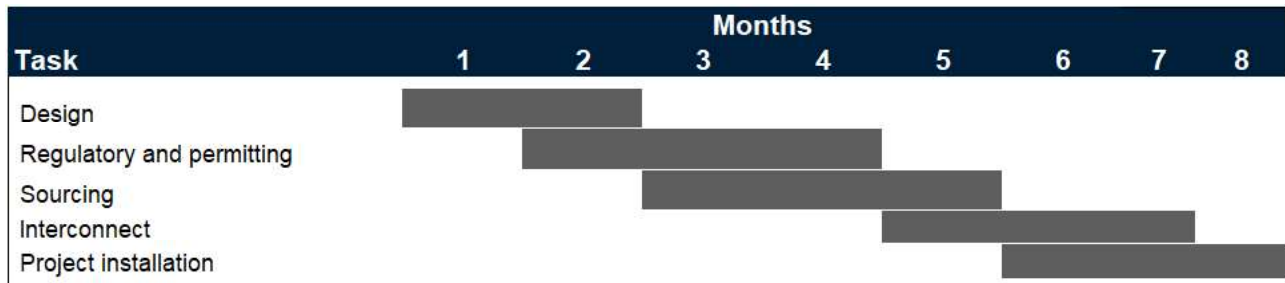

FEE SCHEDULE

InPipe Energy shall deliver a turn-key project (design-build) as summarized in the table below.

Tasks	Project delivery	Deliverable and timing
Task 1: Design	\$75,000	Final design drawings
Task 2: Regulatory support	\$5,000	Filing of FERC Exemption
Task 3: Supply of HydroXS Energy System and related equipment including a minimum of one EV charging station	\$530,000	75% at contract execution. 25% on shipment
Task 4: Mechanical & Electrical Installation.	\$340,000	90% Completion of installation 10% Upon notification to operate
Total	\$950,000	

Product is sold FOB Houston, Texas

Skagit PUD is responsible for shipping costs and applicable sales taxes.

This fee schedule includes at least one EV charging equipment and installation. It is anticipated that a meeting shall be convened within 6 weeks of contract execution with Skagit PUD, InPipe Energy and the Mount Vernon School District to finalize requirements, including EV charging.

INTERLOCAL AGREEMENT
BETWEEN
MOUNT VERNON SCHOOL DISTRICT (“District”)
AND
PUBLIC UTILITY DISTRICT NO.1 OF SKAGIT COUNTY (“Skagit PUD”)
FOR
PROVISIONS
ASSOCIATED WITH MOUNT VERNON HIGH SCHOOL HYDROELECTRIC
ENERGY RECOVERY PROJECT

THIS INTERLOCAL AGREEMENT (the “Agreement”) is made this **28th** day of May, 2024, between Mount Vernon School District, a political subdivision of the State of Washington (hereinafter “District”), and Public Utility District No.1 of Skagit County, a Washington municipal corporation (hereinafter “Skagit PUD”). Skagit PUD and District are jointly referred to herein as (the “Parties”) and individually as (“Party”).

WHEREAS, the Skagit PUD’s core values include Environmental Stewardship – *“We act to preserve our region’s natural resources”*; and

WHEREAS, Skagit PUD and the District are both public government entities; and

WHEREAS, it is in the public interest for the Parties to work in a cooperative manner; and

WHEREAS, Skagit PUD is authorized to engage in the provision of supplying, operating, and maintaining water distributions systems; and

WHEREAS, Skagit PUD owns and operates mechanical pressure reducing valves at its properties P26762, P26768, P26801, P26804, P26767 and more commonly known as 9th and Highland to lower the pressure from hydraulic grade line (HGL) 459 to 219; and

WHEREAS, Skagit PUD plan to replace the existing mechanical pressure reducing valve with an InPipe energy recovery system, which is able to reduce the pressure in the waterline and provide the same utility as a mechanical PRV while generating electricity; and

WHEREAS, the Skagit PUD electrical services at the point of generation only consume a fraction of the electricity generated; and

WHEREAS, any additional electricity generated on site and not consumed is waste; and

WHEREAS, the energy recovered at the Skagit PUD water system site is adjacent to the Mount Vernon High School where the electrical demand will exceed the amount of electricity generated; and

WHEREAS, Puget Sound Energy identifies customers of meters and not owners of the property the meters serve; and

WHEREAS, Transferring the existing meter ownership from Skagit PUD to the District is agreeable to Puget Sound Energy; and

WHEREAS, The energy otherwise wasted at the 9th and Highland Site meter can be used to offset consumption on an existing meter on the adjacent school campus; and

WHEREAS, Since the District is the customer for two meters on adjacent properties, both meters, can aggregate the net metering benefit; and

WHEREAS, The Skagit PUD will operate the InPipe energy recovery unit and the excess power will be sent through the meters located at and serving Skagit PUD facilities at 9th and Highland to PSE for the benefit of the District; and

WHEREAS, The District would be responsible for payment (credit) of Skagit PUD's net consumption through the meter serving Skagit PUD's facilities at 9th and Highland and electrical vehicle charging stations available for use by the District, District staff, or District students as authorized by District; and

WHEREAS, Having the meter located at the 9th and Highland site under the District's ownership reduces construction costs for routing power from the InPipe energy recovery unit to the school; and

WHEREAS, the Skagit PUD has secured full funding for the Mount Vernon High School Energy Recovery Demonstration Project, as further defined in Section 1 herein, from state and federal sources that is separate from any rates collected by the Skagit PUD; and

WHEREAS, Skagit PUD and the District desire to enter into this Agreement under the terms and conditions of Chapter 39.34 RCW (entitled the Interlocal Cooperation Act);

NOW, THEREFORE, in consideration of the mutual covenants contained herein, Skagit PUD and District agree as follows:

1.0 PURPOSE.

The above recitals are incorporated herein by reference. The purpose of this Agreement is to establish a relationship between the Parties where they can combine, share, and use their respective skills and assets, thereby efficiently consuming waste energy harvested by the InPipe energy recovery unit within the Skagit PUD water distribution system, all as described more fully in the Whereas clauses. The Inpipe energy recovery system is located at the Skagit PUD's 9th and Highland Tank site adjacent to the Mount Vernon School High School and is referred to as the "Project". The cooperative efforts enabled by this Agreement are intended to promote new technologies, recover energy that is otherwise wasted and to reduce the operating cost of electric system operations for the District. The activities enabled by the provisions of this Agreement are in the public interest.

2.0 DECISIONS.

Other than termination of this Agreement according to Section 5.0, all decisions under this Agreement related to the Project and that are not otherwise expressly addressed herein shall be by consensus of the Parties, subject to the financial, technical, and legal perspectives of both Parties. In the event that the Parties are unable to agree upon a means of undertaking any proposed action not otherwise expressly

addressed herein, then either Party shall have the unilateral right to reject such means, without contributing additional time or other resources to the further negotiation thereof. Failure to agree on such decisions shall not be subject to the arbitration provisions in Section 10.7.

3.0 GENERAL SCOPE OF PROJECT.

Skagit PUD will be the lead on the project managing design, construction, and obtaining all funding for the Project separate from rates, levies, or city taxes. The District's part may include, but not be limited to, the following: From time to time during the term of this Agreement, the District may provide qualified staff to Skagit PUD for assistance with matters related to the school's electric power supply management and the transmission, distribution, and/or use of such power procured.

Engineering Services: Electric system design, plans review, equipment specifications, and operations for the Mount Vernon High School Energy Recovery Demonstration Project will be provided by Skagit PUD and compensated by grants secured by Skagit PUD.

Construction Management Services: Preparation of bid documents and contractor selection; supervision of contractors, sub-contractors, etc. for the Project will be provided by Skagit PUD.

Operation & Maintenance Services:

- Operation and maintenance of the micro-hydroelectric unit will be provided by the Skagit PUD. The Skagit PUD is under no obligation to guarantee efficient operation of the energy recovery unit as expected but will work diligently to ensure it is operating at its full potential and will be responsive to District requests related to necessary operation and maintenance.
- As many as two electric vehicle charging stations will be placed on Skagit PUD property with direct access from the Mount Vernon High School parking lot for use by authorized District employees, staff, and students. Ownership and management of the system and its access program will be vested in the Skagit PUD. Electrical consumption will be against any net metering.

Power & Transmission Contracts: The District will be the customer of Puget Sound Energy and will be receiving the net metering benefit for the recovered power. The District will be responsible for maintaining an account with Puget Sound Energy for the meters located at the 9th and Highland tank site. Skagit PUD will assist the District in applying for the net metering account associated with the 9th and Highland meters.

Miscellaneous Services: Other services related to the purposes of this Agreement, as agreed to by the Parties.

As the need arises, either Party may propose tasks to be accomplished relative to the overall purposes for which this Agreement has been executed.

4.0 COMPENSATION FOR SERVICES.

Design and construction of the project is funded by third parties through grants secured by Skagit PUD. Skagit PUD will ensure full funding of the Project. Reimbursement between parties for the design and construction is not anticipated.

Skagit PUD will not be invoiced for its electrical consumption used at its property at 9th and Highland, Mount Vernon, WA, and the District will receive the balance of the power that would otherwise be wasted by Skagit PUD. This will be achieved by having the District take responsibility for the Skagit PUD meters at 9th and Highland. This arrangement meets current net metering rules that allow for only one net meter on the site where electricity is generated back into the electrical grid and allows the community a beneficial use of the electricity that would otherwise be wasted.

Any significant maintenance cost required to keep the ERU or electrical vehicle charging stations operational may be invoiced to the District, including costs to maintain or upgrade electrical vehicle charging station software and hardware. Significant costs are those efforts requiring more than \$1,000 in parts, or more than \$2,000 in contracted services annually. Skagit PUD will not undertake any such repairs for which invoicing the District is required unless authorized by District, or they address an urgent safety or vulnerability.

5.0 TERM.

This Agreement shall commence as of the date of this Agreement (i.e. the 28th day of May, 2024), and shall continue until the 1st day of the month of January, year, 2044, unless either Party terminates this Agreement by providing written notice to the other Party, not less than one hundred eighty (180) days prior to the date such party desires the termination or modification to the Agreement to become effective. Either Party may require that the terms and conditions of this Agreement be re-negotiated by providing written notice to the other Party, not less than sixty (60) days prior to the date such party desires the modification to the Agreement to become effective. A notice of re-negotiation shall not be a notice of termination. However, nothing prevents either Party from delivering both a notice of re-negotiation and a notice of termination.

If the Agreement is terminated in accordance with the provisions of this section 5, then the Parties agree to negotiate in good faith to unwind the obligations entered into under this Agreement. If the Parties cannot agree to a resolution of the obligations entered into within ninety days of the termination date of this Agreement, then the Parties agree to submit to binding arbitration, as set forth in Section 10.7 below.

6.0 CONTACT PERSONS.

The following persons, referred to as Contact Person(s), are responsible for the administration of this Agreement for each Party and have the authority to execute Task Orders on behalf of their Party under this Agreement:

For Mount Vernon School District :	Attn: Superintendent
For Skagit PUD:	George Sidhu, General Manager

or such other persons as may be specified from time to time in writing by either Party.

7.0 RELATIONSHIPS OF THE PARTIES.

7.1 The Parties agree that they are each an independent contractor operating pursuant to the terms and conditions of this Agreement. No agent, employee, or representative of a Party shall be deemed to be an employee of any other Party for any purpose. Each Party shall be solely and entirely responsible as an independent contractor for the acts of its beneficiaries, agents, and employees, pursuant to the terms of this Agreement.

7.2 Release by Skagit PUD

To the extent permitted by law, Skagit PUD hereby releases District, its successors and assigns, directors, officers, employees, agents, and representatives of District (each a “District Beneficiary”) from any and all claims, losses, injuries, harm, liabilities, damages, costs, charges and expenses including all reasonable and necessary attorney’s fees incurred in connection with Skagit PUD and it’s employees’ performance under this Agreement.

7.3 Release by Mount Vernon School District of Skagit

To the extent permitted by law, Mount Vernon School District hereby releases Skagit PUD, its successors and assigns, Commissioners, officers, employees, agents, and representatives of Skagit PUD (each a “Skagit PUD Beneficiary”) from any and all claims, losses, injuries, harm, liabilities, damages, costs, charges and expenses including all reasonable and necessary attorney’s fees incurred in connection with District and its’ employees’ performance under this Agreement.

8.0 INDEMNIFICATION.

Each Party, as an indemnitor, agrees to protect, defend, hold harmless, and indemnify each other Party from and against all claims, suits, and actions arising from the intentional or negligent acts or omissions of such indemnitor, its agents, or employees in the performance of this Agreement.

9.0 EXTENT OF AGREEMENT AND MODIFICATIONS.

This Agreement, together with any exhibits and addendums, as may be added upon approval of the Parties, contains all of the terms and conditions agreed upon by the Parties. The Parties agree that there are no understandings, oral or otherwise, modifying or adding to this Agreement. No amendments, changes, or modification of this Agreement shall be valid or binding upon either Party unless such amendment, change, or modification be in writing and executed by both Parties.

10.0 MISCELLANEOUS PROVISIONS.

10.1 *No waiver.* The failure of either Party to insist upon or enforce strict performance by the other Party of any provision of this Agreement or to exercise any right under this Agreement shall not be construed as a waiver or relinquishment to any extent of such Party’s right to assert or rely upon any such provision or right in that or any other instance; rather, the same shall be and remain in full force and effect.

10.2 *Applicable Law.* This Agreement shall be interpreted, construed, and enforced in accordance with the laws of the State of Washington, except to the extent such laws may be preempted by the laws of the United States of America.

10.3 *Venue.* The venue of any litigation arising out of this Agreement shall be in Skagit County, State of Washington, or such other place as both Parties may agree to in writing.

- 10.4 *Standards.* The Parties and the Parties' employees and agents will adhere to applicable professional and ethical standards and will perform all work in a manner consistent with generally accepted skill and care and prudent utility practice for the type of work undertaken.
- 10.5 *Neutral Authorship.* Each of the provisions of this Agreement has been reviewed and negotiated, and represents the combined work product of the Parties. No presumption or other rules of construction, which would interpret the provisions of this Agreement in favor of or against the party preparing the same, shall be applicable in connection with the construction or interpretation of any of the provisions of this Agreement
- 10.6 *Entire Agreement.* This Agreement sets forth the entire Agreement and supersedes any and all prior Agreements of the Parties with respect to the subject matters hereof.
- 10.7 *Arbitration.* The Parties mutually agree to work cooperatively to timely resolve any dispute that may arise between the Parties concerning this Agreement. However, if the Parties cannot mutually settle a dispute, the dispute or claim shall be submitted to binding arbitration. The Parties agree that arbitration shall be governed by the rules and procedures outlined in RCW 7.04 *et.seq.* and that the Parties will jointly stipulate to an arbitrator. In the event that the Parties are unable to agree to an arbitrator, the Parties agree that the Presiding Judge of Skagit County Superior Court may appoint the arbitrator. The prevailing Party as determined by the arbitrator shall be entitled to reasonable attorneys' fees and costs.
- 10.8 *Governing Law and Venue.* The Parties agree that any dispute shall be governed by the laws of the State of Washington, and any proceeding in law or in equity shall be brought in Skagit County.
- 10.9 *Notices.* All notices, demands, requests, consents, and approvals which may, or are required to be given to any party or any other party hereunder, shall be in writing and shall be deemed to have been duly given if delivered personally, sent by facsimile, sent by a nationally recognized overnight delivery service, or if deposited in the United States mail and sent by registered or certified mail, return receipt requested, postage paid to:

Mount Vernon School District : _____

124 E. Lawrence Street
Mount Vernon, WA 98273

Public Utility District No.1 of Skagit Co: _____

1415 Freeway Drive
P.O. Box 1436
Mount Vernon, WA 98273-1436

IN WITNESS WHEREOF, the Parties hereto have caused this Agreement to be executed by their duly authorized representatives all as of the day and year first above written.

MOUNT VERNON SCHOOL DISTRICT

Attest:

PUBLIC UTILITY DISTRICT NO.1 OF SKAGIT COUNTY

Attest:



Interagency Agreement with

Public Utility District No 1. Of Skagit County

through

Rural Energy Innovation Grant Program

Contract Number:
24-92201-032

For

Mount Vernon High School Energy Recovery Demonstration

Dated: Monday, June 3, 2024

Table of Contents

TABLE OF CONTENTS.....	1
FACE SHEET.....	3
DECLARATIONS.....	4
PROGRAM SPECIFIC TERMS AND CONDITIONS.....	5
1. BILLING AND COMPENSATION FOR PERFORMANCE BASED CONTRACT (REPLACES SPECIAL TERMS AND CONDITIONS #4 BILLING PROCEDURES AND PAYMENT).....	5
2. SUBCONTRACTING (REPLACES GENERAL TERMS AND CONDITIONS #15 SUBCONTRACTING).....	6
3. PREVAILING WAGE LAW.....	6
4. HISTORICAL OR CULTURAL ARTIFACTS.....	6
5. ACKNOWLEDGMENT OF CLIMATE COMMITMENT ACT FUNDING.....	7
SPECIAL TERMS AND CONDITIONS.....	8
1. AUTHORITY.....	8
2. CONTRACT MANAGEMENT.....	8
3. COMPENSATION.....	8
4. BILLING PROCEDURES AND PAYMENT (REPLACED BY PROGRAM SPECIFIC TERMS AND CONDITIONS #1 BILLING AND COMPENSATION FOR PERFORMANCE BASED CONTRACT).....	8
5. SUBCONTRACTOR DATA COLLECTION.....	9
6. INSURANCE.....	9
7. FRAUD AND OTHER LOSS REPORTING.....	9
8. ORDER OF PRECEDENCE.....	9
GENERAL TERMS AND CONDITIONS.....	10
1. DEFINITIONS.....	10
2. ALL WRITINGS CONTAINED HEREIN.....	10
3. AMENDMENTS.....	10
4. ASSIGNMENT.....	10
5. CONFIDENTIALITY AND SAFEGUARDING OF INFORMATION.....	10
6. COPYRIGHT.....	11
7. DISPUTES.....	11
8. GOVERNING LAW AND VENUE.....	12
9. INDEMNIFICATION.....	12
10. LICENSING, ACCREDITATION AND REGISTRATION.....	12
11. RECAPTURE.....	12
12. RECORDS MAINTENANCE.....	12
13. SAVINGS.....	12
14. SEVERABILITY.....	12
15. SUBCONTRACTING (REPLACED BY PROGRAM SPECIFIC TERMS AND CONDITIONS #2 SUBCONTRACTING).....	13
16. SURVIVAL.....	13
17. TERMINATION FOR CAUSE.....	13
18. TERMINATION FOR CONVENIENCE.....	13
19. TERMINATION PROCEDURES.....	13
20. TREATMENT OF ASSETS.....	14
21. WAIVER.....	15

ATTACHMENT A: SCOPE OF WORK..... 16

ATTACHMENT B: BUDGET 18

ATTACHMENT C: REPORTING..... 19

ATTACHMENT D: PROVISIO..... 20

Face Sheet

Contract Number: 24-92201-032

**Energy Division - Energy Programs In Communities Unit
Rural Energy Innovation Program**

1. Contractor Public Utility District No 1. Of Skagit County 14515 Freeway Drive Mount Vernon, WA 98273		2. Contractor Doing Business As (as applicable) N/A	
3. Contractor Representative Mark Handzlik Engineering Manager 360-853-6305 handzlik@skagitPUD.org		4. COMMERCE Representative Brianna Gomez-Catalan PO BOX 42525 Program Manager 1011 Plum St. NE 360-725-2802 Olympia, WA 98504-2525 Brianna.gomez-catalan@commerce.wa.gov	
5. Contract Amount \$598,800	6. Funding Source Federal: <input type="checkbox"/> State: <input checked="" type="checkbox"/> Other: <input type="checkbox"/> N/A: <input type="checkbox"/>		7. Start Date 06/01/2024
8. End Date 03/31/2025			
9. Federal Funds (as applicable) N/A		Federal Agency: N/A	
ALN N/A			
10. Tax ID # 916001038	11. SWV # 000 2325-00	12. UBI # 297-000-991	13. UEI # N/A
14. Contract Purpose To design, assemble and install a demonstration Energy Recovery Valve (ERV) system and at least one Electrical Vehicle (EV) charger, which will directly benefit the population of the Mount Vernon High School.			
COMMERCE, defined as the Department of Commerce, and the Contractor, as defined above, acknowledge and accept the terms of this Contract and Attachments and have executed this Contract on the date below and warrant they are authorized to bind their respective agencies. The rights and obligations of both parties to this Contract are governed by this Contract and the following documents incorporated by reference: Contractor Terms and Conditions including Attachment "A" – Scope of Work, Attachment "B" – Budget, Attachment "C" –Reporting, Attachment "D" - Proviso			
FOR CONTRACTOR _____ George Sidhu, General Manager _____ Date		FOR COMMERCE _____ Michael Furze, Assistant Director, Energy Division _____ Date APPROVED AS TO FORM ONLY BY ASSISTANT ATTORNEY GENERAL APPROVAL ON FILE	

DECLARATIONS

The Washington State Department of Commerce (Commerce) has been appropriated funds under Section 1064 of the 2021 Capital Budget (Substitute House Bill 1080) to provide grants to develop targeted rural clean energy innovation projects.

CLIENT INFORMATION

Legal Name:	Public Utility District No. 1 of Skagit County
Agreement Number:	24-92201-032
Award Year:	2023
State Wide Vendor Number:	000 2325-00

PROJECT INFORMATION

Project Title:	Mount Vernon High School Energy Recovery Demonstration
Project Address:	314 N 9th St.
Project City:	Mt Vernon
Project State:	Washington
Project Zip Code:	98273

GRANT INFORMATION

Grant Amount:	\$598,800
Non-State Match (1:5)	\$351,200
Type of Match Accepted:	TransAlta Coal Transition Grant, & IRS Credits
Earliest Date for Reimbursement:	06/01/2024
Time of Performance:	06/01/2024 – 03/31/2025

Program Specific Terms and Conditions

As identified herein, notwithstanding General & Specific Terms and Conditions SECTIONS, the following Program Specific Terms and Conditions take precedence over any similarly referenced Special or General Terms and Conditions:

1. **BILLING AND COMPENSATION FOR PERFORMANCE BASED CONTRACT (Replaces Special Terms and Conditions #4 Billing Procedures and Payment)**

COMMERCE will pay Contractor not more often than monthly upon acceptance of services provided and receipt of properly completed invoices for completed milestones, which shall be submitted to the Representative for COMMERCE.

The Contractor shall provide the Representative of COMMERCE a signed electronic Invoice A19 form that includes the contract number referenced on the declarations page.

The invoices shall describe and document, to COMMERCE's satisfaction, a description of the work performed and the milestone number(s) achieved.

The Contractor is required to maintain documentation to support invoiced costs and cost share obligations. The Contractor shall make these documents available to COMMERCE if requested.

COMMERCE will pay Contractor the amounts set forth in Attachment B upon full completion of each milestone. Upon full completion of each Milestone, Contractor will provide an invoice and any required supporting documentation to the Representative of COMMERCE. Except as may be agreed by COMMERCE in its discretion, COMMERCE shall only be obligated to make payments upon demonstration of completion of all Deliverables within a given Milestone.

However, it is acknowledged that in the event one or two Deliverables of a Milestone is unduly delayed (more than 3 months) due to circumstances outside Contractor's control, COMMERCE may, in its sole discretion, reasonably negotiate with Contractor regarding paying for those Deliverables of such Milestones that are completed.

Payment shall be considered timely if made by COMMERCE within thirty (30) calendar days after receipt of properly completed invoices. Payment shall be sent to the address designated by the Contractor.

COMMERCE may, in its sole discretion, terminate the Contract or withhold payments claimed by the Contractor for services rendered if the Contractor fails to satisfactorily comply with any term or condition of this Contract.

No payments in advance or in anticipation of services or supplies to be provided under this Agreement shall be made by COMMERCE.

Invoices and End of Fiscal Year

Invoices are due on the 20th of the month following the provision of services.

Final invoices for a state fiscal year may be due sooner than the 20th and Commerce will provide notification of the end of fiscal year due date.

The contractor must invoice for all expenses from the beginning of the contract through June 30, regardless of the contract start and end date.

Duplication of Billed Costs

The Contractor shall not bill COMMERCE for services performed under this Agreement, and COMMERCE shall not pay the Contractor, if the Contractor is entitled to payment or has been or will be paid by any other source, including grants, for that service.

Disallowed Costs

The Contractor is responsible for any audit exceptions or disallowed costs incurred by its own organization or that of its subcontractors.

2. **SUBCONTRACTING (Replaces General Terms and Conditions #15 Subcontracting)**

The Contractor may only subcontract work contemplated under this Contract if it provides written notification to COMMERCE of any subcontractors who will be performing work under this Grant Agreement. The written notice must provide the names and address of the subcontractor with a brief description of which tasks within the Contractor Scope of Work (Attachment A) that will be undertaken by the subcontractor(s).

The Contractor shall maintain written procedures related to subcontracting, as well as copies of all subcontracts and records related to subcontracts. For cause, COMMERCE in writing may: (a) require the Contractor to amend its subcontracting procedures as they relate to this Contract; (b) prohibit the Contractor from subcontracting with a particular person or entity; or (c) require the Contractor to rescind or amend a subcontract.

Every subcontract shall bind the Subcontractor to follow all applicable terms of this Contract. The Contractor is responsible to COMMERCE if the Subcontractor fails to comply with any applicable term or condition of this Contract. The Contractor shall appropriately monitor the activities of the Subcontractor to assure fiscal conditions of this Contract.

In no event shall the existence of a subcontract operate to release or reduce the liability of the Contractor to COMMERCE for any breach in the performance of the Contractor's duties. Every subcontract shall include a term that COMMERCE and the State of Washington are not liable for claims or damages arising from a Subcontractor's performance of the subcontract.

All reference to the Contractor under this clause shall also include Contractor's employees, agents or subcontractors.

3. **PREVAILING WAGE LAW**

The contractor certifies that all contractors and subcontractors performing work on the Project shall comply with state Prevailing Wages on Public Works, Chapter 39.12 RCW, as applicable to the Project funded by this Agreement, including but not limited to the filing of the "Statement of Intent to Pay Prevailing Wages" and "Affidavit of Wages Paid" as required by RCW 39.12.040. The contractor shall maintain records sufficient to evidence compliance with Chapter 39.12 RCW, and shall make such records available for COMMERCE's review upon request

4. **HISTORICAL OR CULTURAL ARTIFACTS**

Prior to approval and disbursement of any funds awarded under this Contract, Contractor shall complete the requirements of Governor's Executive Order 21-02, where applicable, or Contractor shall complete a review under Section 106 of the National Historic Preservation Act, if applicable.

Contractor agrees that the Contractor is legally and financially responsible for compliance with all laws, regulations, and agreements related to the preservation of historical or cultural resources and agrees to hold harmless COMMERCE and the state of Washington in relation to any claim related

to such historical or cultural resources discovered, disturbed, or damaged as a result of the project funded by this Contract.

In addition to the requirements set forth in this Contract, Contractor shall, in accordance with Governor's Executive Order 21-02 coordinate with Commerce and the Washington State Department of Archaeology and Historic Preservation ("DAHP"), including any recommended consultation with any affected tribe(s), during Project design and prior to construction to determine the existence of any tribal cultural resources affected by Project. Contractor agrees to avoid, minimize, or mitigate impacts to the cultural resource as a continuing prerequisite to receipt of funds under this Contract.

The Contractor agrees that, unless the Contractor is proceeding under an approved historical and cultural monitoring plan or other memorandum of agreement, if historical or cultural artifacts are discovered during construction, the Contractor shall immediately stop construction and notify the local historical preservation officer and the state's historical preservation officer at DAHP, and the Commerce Representative identified on the Face Sheet. If human remains are uncovered, the Contractor shall report the presence and location of the remains to the coroner and local enforcement immediately, then contact DAHP and the concerned tribe's cultural staff or committee.

The Contractor shall require this provision to be contained in all subcontracts for work or services related to the Scope of Work attached hereto.

In addition to the requirements set forth in this Contract, Contractor agrees to comply with RCW 27.44 regarding Indian Graves and Records; RCW 27.53 regarding Archaeological Sites and Resources; RCW 68.60 regarding Abandoned and Historic Cemeteries and Historic Graves; and WAC 25-48 regarding Archaeological Excavation and Removal Permit.

Completion of the requirements of Section 106 of the National Historic Preservation Act shall substitute for completion of Governor's Executive Order 21-02.

In the event that the Contractor finds it necessary to amend the Scope of Work the Contractor may be required to re-comply with Governor's Executive Order 21-02 or Section 106 of the National Historic Preservation Act

5. ACKNOWLEDGMENT OF CLIMATE COMMITMENT ACT FUNDING

If this Agreement is funded in whole or in part by the Climate Commitment Act, Grantee agrees that any website, announcement, press release, and/or publication (written, visual, or sound) used for media-related activities, publicity, and public outreach issued by or on behalf of Grantee which reference programs or projects funded in whole or in part with Washington's Climate Commitment Act (CCA) funds under this Grant, shall contain the following statement:

"The [PROGRAM NAME / GRANT / ETC.] is supported with funding from Washington's Climate Commitment Act. The CCA supports Washington's climate action efforts by putting cap-and-invest dollars to work reducing climate pollution, creating jobs, and improving public health. Information about the CCA is available at www.climate.wa.gov."

The Grantee agrees to ensure coordinated Climate Commitment Act branding on work completed by or on behalf of the Grantee. The CCA logo must be used in the following circumstances, consistent with the branding guidelines posted at [CCA brand toolkit](#), including:

- A. Any project related website or webpage that includes logos from other funding partners;
- B. Any publication materials that include logos from other funding partners;
- C. Any on-site signage including pre-during Construction signage and permanent signage at completed project sites; and
- D. Any equipment purchased with CAA funding through a generally visible decal.

Special Terms and Conditions

1. AUTHORITY

COMMERCE and Contractor enter into this Contract pursuant to the authority granted by Chapter 39.34 RCW.

2. CONTRACT MANAGEMENT

The Representative for each of the parties shall be responsible for and shall be the contact person for all communications and billings regarding the performance of this Contract.

The Representative for COMMERCE and their contact information are identified on the Face Sheet of this Contract.

The Representative for the Contractor and their contact information are identified on the Face Sheet of this Contract.

3. COMPENSATION

COMMERCE shall pay an amount not to exceed \$598,800, for the performance of all things necessary for or incidental to the performance of work under this Contract as set forth in the Scope of Work.

EXPENSES

Contractor shall receive reimbursement for travel and other expenses as identified below or as authorized in advance by COMMERCE as reimbursable. The maximum amount to be paid to the Contractor for authorized expenses shall not exceed \$0, which amount is included in the Contract total above.

Such expenses may include airfare (economy or coach class only), other transportation expenses, and lodging and subsistence necessary during periods of required travel. Contractor shall receive compensation for travel expenses at current state travel reimbursement rates.

4. BILLING PROCEDURES AND PAYMENT (Replaced by Program Specific Terms and Conditions #1 Billing and Compensation for Performance Based Contract)

~~COMMERCE will pay Contractor upon acceptance of services provided and receipt of properly completed invoices, which shall be submitted to the Representative for COMMERCE not more often than monthly nor less than quarterly.~~

~~The invoices shall describe and document, to COMMERCE's satisfaction, a description of the work performed, the progress of the project, and fees. The invoice shall include the Contract Number _____. If expenses are invoiced, provide a detailed breakdown of each type. A receipt must accompany any single expenses in the amount of \$50.00 or more in order to receive reimbursement. Payment shall be considered timely if made by COMMERCE within thirty (30) calendar days after receipt of properly completed invoices. Payment shall be sent to the address designated by the Contractor.~~

~~COMMERCE may, in its sole discretion, terminate the Contract or withhold payments claimed by the Contractor for services rendered if the Contractor fails to satisfactorily comply with any term or condition of this Contract.~~

~~No payments in advance or in anticipation of services or supplies to be provided under this Agreement shall be made by COMMERCE.~~

~~Invoices and End of Fiscal Year~~

~~Invoices are due on the 20th of the month following the provision of services.~~

~~Final invoices for a state fiscal year may be due sooner than the 20th and Commerce will provide notification of the end of fiscal year due date. The Contractor must invoice for all expenses from the beginning of the contract through June 30, regardless of the contract start and end date.~~

~~Duplication of Billed Costs~~

~~The Contractor shall not bill COMMERCE for services performed under this Agreement, and COMMERCE shall not pay the Contractor, if the Contractor is entitled to payment or has been or will be paid by any other source, including grants, for that service.~~

~~Disallowed Costs~~

~~The Contractor is responsible for any audit exceptions or disallowed costs incurred by its own organization or that of its subcontractors.~~

~~COMMERCE may, in its sole discretion, withhold ten percent (10%) from each payment until acceptance by COMMERCE of the final report (or completion of the project, etc.).~~

5. SUBCONTRACTOR DATA COLLECTION

Contractor will submit reports, in a form and format to be provided by Commerce and at intervals as agreed by the parties, regarding work under this Contract performed by subcontractors and the portion of Contract funds expended for work performed by subcontractors, including but not necessarily limited to minority-owned, woman-owned, and veteran-owned business subcontractors. "Subcontractors" shall mean subcontractors of any tier.

6. INSURANCE

Each party certifies that it is self-insured under the State's or local government self-insurance liability program, and shall be responsible for losses for which it is found liable.

7. FRAUD AND OTHER LOSS REPORTING

Contractor shall report in writing all known or suspected fraud or other loss of any funds or other property furnished under this Contract immediately or as soon as practicable to the Commerce Representative identified on the Face Sheet.

8. ORDER OF PRECEDENCE

In the event of an inconsistency in this Contract, the inconsistency shall be resolved by giving precedence in the following order:

- Applicable federal and state of Washington statutes and regulations
- Attachment D – Proviso
- Program Specific Terms and Conditions
- Special Terms and Conditions
- General Terms and Conditions
- Attachment A – Scope of Work
- Attachment B – Budget
- Attachment C – Reporting

General Terms and Conditions

1. DEFINITIONS

As used throughout this Contract, the following terms shall have the meaning set forth below:

- A. "Authorized Representative" shall mean the Director and/or the designee authorized in writing to act on the Director's behalf.
- B. "COMMERCE" shall mean the Washington Department of Commerce.
- C. "Contract" or "Agreement" or "Grant" means the entire written agreement between COMMERCE and the Contractor, including any Attachments, documents, or materials incorporated by reference. E-mail or Facsimile transmission of a signed copy of this contract shall be the same as delivery of an original.
- D. "Contractor" or "Grantee" shall mean the entity identified on the face sheet performing service(s) under this Contract, and shall include all employees and agents of the Contractor.
- E. "Personal Information" shall mean information identifiable to any person, including, but not limited to, information that relates to a person's name, health, finances, education, business, use or receipt of governmental services or other activities, addresses, telephone numbers, social security numbers, driver license numbers, other identifying numbers, and any financial identifiers, and "Protected Health Information" under the federal Health Insurance Portability and Accountability Act of 1996 (HIPAA).
- F. "State" shall mean the state of Washington.
- G. "Subcontractor" shall mean one not in the employment of the Contractor, who is performing all or part of those services under this Contract under a separate contract with the Contractor. The terms "subcontractor" and "subcontractors" mean subcontractor(s) in any tier.

2. ALL WRITINGS CONTAINED HEREIN

This Contract contains all the terms and conditions agreed upon by the parties. No other understandings, oral or otherwise, regarding the subject matter of this Contract shall be deemed to exist or to bind any of the parties hereto.

3. AMENDMENTS

This Contract may be amended by mutual agreement of the parties. Such amendments shall not be binding unless they are in writing and signed by personnel authorized to bind each of the parties.

4. ASSIGNMENT

Neither this Contract, work thereunder, nor any claim arising under this Contract, shall be transferred or assigned by the Contractor without prior written consent of COMMERCE.

5. CONFIDENTIALITY AND SAFEGUARDING OF INFORMATION

- A. "Confidential Information" as used in this section includes:
 - i. All material provided to the Contractor by COMMERCE that is designated as "confidential" by COMMERCE;
 - ii. All material produced by the Contractor that is designated as "confidential" by COMMERCE; and

iii. All Personal Information in the possession of the Contractor that may not be disclosed under state or federal law.

- B.** The Contractor shall comply with all state and federal laws related to the use, sharing, transfer, sale, or disclosure of Confidential Information. The Contractor shall use Confidential Information solely for the purposes of this Contract and shall not use, share, transfer, sell or disclose any Confidential Information to any third party except with the prior written consent of COMMERCE or as may be required by law.

The Contractor shall take all necessary steps to assure that Confidential Information is safeguarded to prevent unauthorized use, sharing, transfer, sale or disclosure of Confidential Information or violation of any state or federal laws related thereto. Upon request, the Contractor shall provide COMMERCE with its policies and procedures on confidentiality. COMMERCE may require changes to such policies and procedures as they apply to this Contract whenever COMMERCE reasonably determines that changes are necessary to prevent unauthorized disclosures.

The Contractor shall make the changes within the time period specified by COMMERCE. Upon request, the Contractor shall immediately return to COMMERCE any Confidential Information that COMMERCE reasonably determines has not been adequately protected by the Contractor against unauthorized disclosure.

- C.** Unauthorized Use or Disclosure. The Contractor shall notify COMMERCE within five (5) working days of any unauthorized use or disclosure of any confidential information, and shall take necessary steps to mitigate the harmful effects of such use or disclosure.

6. COPYRIGHT

Unless otherwise provided, all Materials produced under this Contract shall be considered "works for hire" as defined by the U.S. Copyright Act and shall be owned by COMMERCE. COMMERCE shall be considered the author of such Materials. In the event the Materials are not considered "works for hire" under the U.S. Copyright laws, the Contractor hereby irrevocably assigns all right, title, and interest in all Materials, including all intellectual property rights, moral rights, and rights of publicity to COMMERCE effective from the moment of creation of such Materials.

"Materials" means all items in any format and includes, but is not limited to, data, reports, documents, pamphlets, advertisements, books, magazines, surveys, studies, computer programs, films, tapes, and/or sound reproductions. "Ownership" includes the right to copyright, patent, register and the ability to transfer these rights.

For Materials that are delivered under the Contract, but that incorporate pre-existing materials not produced under the Contract, the Contractor hereby grants to COMMERCE a nonexclusive, royalty-free, irrevocable license (with rights to sublicense to others) in such Materials to translate, reproduce, distribute, prepare derivative works, publicly perform, and publicly display. The Contractor warrants and represents that the Contractor has all rights and permissions, including intellectual property rights, moral rights and rights of publicity, necessary to grant such a license to COMMERCE.

The Contractor shall exert all reasonable effort to advise COMMERCE, at the time of delivery of Materials furnished under this Contract, of all known or potential invasions of privacy contained therein and of any portion of such document which was not produced in the performance of this Contract. The Contractor shall provide COMMERCE with prompt written notice of each notice or claim of infringement received by the Contractor with respect to any Materials delivered under this Contract. COMMERCE shall have the right to modify or remove any restrictive markings placed upon the Materials by the Contractor.

7. DISPUTES

In the event that a dispute arises under this Agreement, it shall be determined by a Dispute Board in the following manner: Each party to this Agreement shall appoint one member to the Dispute Board. The members so appointed shall jointly appoint an additional member to the Dispute Board. The

Dispute Board shall review the facts, Agreement terms and applicable statutes and rules and make a determination of the dispute. The Dispute Board shall thereafter decide the dispute with the majority prevailing. The determination of the Dispute Board shall be final and binding on the parties hereto. As an alternative to this process, either of the parties may request intervention by the Governor, as provided by RCW 43.17.330, in which event the Governor's process will control.

8. GOVERNING LAW AND VENUE

This Contract shall be construed and interpreted in accordance with the laws of the state of Washington, and the venue of any action brought hereunder shall be in the Superior Court for Thurston County.

9. INDEMNIFICATION

Each party shall be solely responsible for the acts of its employees, officers, and agents.

10. LICENSING, ACCREDITATION AND REGISTRATION

The Contractor shall comply with all applicable local, state, and federal licensing, accreditation and registration requirements or standards necessary for the performance of this Contract.

11. RECAPTURE

In the event that the Contractor fails to perform this Contract in accordance with state laws, federal laws, and/or the provisions of this Contract, COMMERCE reserves the right to recapture funds in an amount to compensate COMMERCE for the noncompliance in addition to any other remedies available at law or in equity.

Repayment by the Contractor of funds under this recapture provision shall occur within the time period specified by COMMERCE. In the alternative, COMMERCE may recapture such funds from payments due under this Contract.

12. RECORDS MAINTENANCE

The Contractor shall maintain books, records, documents, data and other evidence relating to this contract and performance of the services described herein, including but not limited to accounting procedures and practices that sufficiently and properly reflect all direct and indirect costs of any nature expended in the performance of this contract.

The Contractor shall retain such records for a period of six years following the date of final payment. At no additional cost, these records, including materials generated under the contract, shall be subject at all reasonable times to inspection, review or audit by COMMERCE, personnel duly authorized by COMMERCE, the Office of the State Auditor, and federal and state officials so authorized by law, regulation or agreement.

If any litigation, claim or audit is started before the expiration of the six (6) year period, the records shall be retained until all litigation, claims, or audit findings involving the records have been resolved.

13. SAVINGS

In the event funding from state, federal, or other sources is withdrawn, reduced, or limited in any way after the effective date of this Contract and prior to normal completion, COMMERCE may suspend or terminate the Contract under the "Termination for Convenience" clause, without the ten calendar day notice requirement. In lieu of termination, the Contract may be amended to reflect the new funding limitations and conditions.

14. SEVERABILITY

The provisions of this contract are intended to be severable. If any term or provision is illegal or invalid for any reason whatsoever, such illegality or invalidity shall not affect the validity of the remainder of the contract.

15. SUBCONTRACTING (Replaced by Program Specific Terms and Conditions #2 Subcontracting)

~~The Contractor may only subcontract work contemplated under this Contract if it obtains the prior written approval of COMMERCE.~~

~~If COMMERCE approves subcontracting, the Contractor shall maintain written procedures related to subcontracting, as well as copies of all subcontracts and records related to subcontracts. For cause, COMMERCE in writing may: (a) require the Contractor to amend its subcontracting procedures as they relate to this Contract; (b) prohibit the Contractor from subcontracting with a particular person or entity; or (c) require the Contractor to rescind or amend a subcontract.~~

~~Every subcontract shall bind the Subcontractor to follow all applicable terms of this Contract. The Contractor is responsible to COMMERCE if the Subcontractor fails to comply with any applicable term or condition of this Contract. The Contractor shall appropriately monitor the activities of the Subcontractor to assure fiscal conditions of this Contract. In no event shall the existence of a subcontract operate to release or reduce the liability of the Contractor to COMMERCE for any breach in the performance of the Contractor's duties.~~

~~Every subcontract shall include a term that COMMERCE and the State of Washington are not liable for claims or damages arising from a Subcontractor's performance of the subcontract.~~

16. SURVIVAL

The terms, conditions, and warranties contained in this Contract that by their sense and context are intended to survive the completion of the performance, cancellation or termination of this Contract shall so survive.

17. TERMINATION FOR CAUSE

In the event COMMERCE determines the Contractor has failed to comply with the conditions of this contract in a timely manner, COMMERCE has the right to suspend or terminate this contract. Before suspending or terminating the contract, COMMERCE shall notify the Contractor in writing of the need to take corrective action. If corrective action is not taken within 30 calendar days, the contract may be terminated or suspended.

In the event of termination or suspension, the Contractor shall be liable for damages as authorized by law including, but not limited to, any cost difference between the original contract and the replacement or cover contract and all administrative costs directly related to the replacement contract, e.g., cost of the competitive bidding, mailing, advertising and staff time.

COMMERCE reserves the right to suspend all or part of the contract, withhold further payments, or prohibit the Contractor from incurring additional obligations of funds during investigation of the alleged compliance breach and pending corrective action by the Contractor or a decision by COMMERCE to terminate the contract. A termination shall be deemed a "Termination for Convenience" if it is determined that the Contractor: (1) was not in default; or (2) failure to perform was outside of his or her control, fault or negligence.

The rights and remedies of COMMERCE provided in this contract are not exclusive and are, in addition to any other rights and remedies, provided by law.

18. TERMINATION FOR CONVENIENCE

Except as otherwise provided in this Contract, COMMERCE may, by ten (10) business days' written notice, beginning on the second day after the mailing, terminate this Contract, in whole or in part. If this Contract is so terminated, COMMERCE shall be liable only for payment required under the terms of this Contract for services rendered or goods delivered prior to the effective date of termination.

19. TERMINATION PROCEDURES

Upon termination of this contract, COMMERCE, in addition to any other rights provided in this contract, may require the Contractor to deliver to COMMERCE any property specifically produced or

acquired for the performance of such part of this contract as has been terminated. The provisions of the "Treatment of Assets" clause shall apply in such property transfer.

COMMERCE shall pay to the Contractor the agreed upon price, if separately stated, for completed work and services accepted by COMMERCE, and the amount agreed upon by the Contractor and COMMERCE for (i) completed work and services for which no separate price is stated, (ii) partially completed work and services, (iii) other property or services that are accepted by COMMERCE, and (iv) the protection and preservation of property, unless the termination is for default, in which case the Authorized Representative shall determine the extent of the liability of COMMERCE. Failure to agree with such determination shall be a dispute within the meaning of the "Disputes" clause of this contract. COMMERCE may withhold from any amounts due the Contractor such sum as the Authorized Representative determines to be necessary to protect COMMERCE against potential loss or liability.

The rights and remedies of COMMERCE provided in this section shall not be exclusive and are in addition to any other rights and remedies provided by law or under this contract.

After receipt of a notice of termination, and except as otherwise directed by the Authorized Representative, the Contractor shall:

- A. Stop work under the contract on the date, and to the extent specified, in the notice;
- B. Place no further orders or subcontracts for materials, services, or facilities except as may be necessary for completion of such portion of the work under the contract that is not terminated;
- C. Assign to COMMERCE, in the manner, at the times, and to the extent directed by the Authorized Representative, all of the rights, title, and interest of the Contractor under the orders and subcontracts so terminated, in which case COMMERCE has the right, at its discretion, to settle or pay any or all claims arising out of the termination of such orders and subcontracts;
- D. Settle all outstanding liabilities and all claims arising out of such termination of orders and subcontracts, with the approval or ratification of the Authorized Representative to the extent the Authorized Representative may require, which approval or ratification shall be final for all the purposes of this clause;
- E. Transfer title to COMMERCE and deliver in the manner, at the times, and to the extent directed by the Authorized Representative any property which, if the contract had been completed, would have been required to be furnished to COMMERCE;
- F. Complete performance of such part of the work as shall not have been terminated by the Authorized Representative; and
- G. Take such action as may be necessary, or as the Authorized Representative may direct, for the protection and preservation of the property related to this contract, which is in the possession of the Contractor and in which COMMERCE has or may acquire an interest.

20. TREATMENT OF ASSETS

Title to all property furnished by COMMERCE shall remain in COMMERCE. Title to all property furnished by the Contractor, for the cost of which the Contractor is entitled to be reimbursed as a direct item of cost under this contract, shall pass to and vest in COMMERCE upon delivery of such property by the Contractor. Title to other property, the cost of which is reimbursable to the Contractor under this contract, shall pass to and vest in COMMERCE upon (i) issuance for use of such property in the performance of this contract, or (ii) commencement of use of such property in the performance of this contract, or (iii) reimbursement of the cost thereof by COMMERCE in whole or in part, whichever first occurs.

- A. Any property of COMMERCE furnished to the Contractor shall, unless otherwise provided herein or approved by COMMERCE, be used only for the performance of this contract.

- B.** The Contractor shall be responsible for any loss or damage to property of COMMERCE that results from the negligence of the Contractor or which results from the failure on the part of the Contractor to maintain and administer that property in accordance with sound management practices.
- C.** If any COMMERCE property is lost, destroyed or damaged, the Contractor shall immediately notify COMMERCE and shall take all reasonable steps to protect the property from further damage.
- D.** The Contractor shall surrender to COMMERCE all property of COMMERCE prior to settlement upon completion, termination or cancellation of this contract.
- E.** All reference to the Contractor under this clause shall also include Contractor's employees, agents or Subcontractors.

21. WAIVER

Waiver of any default or breach shall not be deemed to be a waiver of any subsequent default or breach. Any waiver shall not be construed to be a modification of the terms of this Contract unless stated to be such in writing and signed by Authorized Representative of COMMERCE.

Attachment A: Scope of Work

Project Overview: The project objectives are to design, assemble and install a demonstration Energy Recovery Valve (ERV) system and at least one Electrical Vehicle (EV) charger, which will directly benefit the population of the Mount Vernon High School.

This project will tap into a new source of local clean energy – wasted pressure in water delivery. Energy is used to pressurize water through pumps as it moves through pipes. To ensure precise pressurization at each point of delivery, pressure is adjusted, controlled and vented via control valves. Without a mechanism for recapture, the pressure vented through these valves is lost as wasted heat. A new energy technology, an energy recovery valve (ERV), is a first-of-its-kind, digitally enabled renewable energy system that converts flowing water to electricity in existing and new pressurized water pipelines.

There exists in the water distribution system of the Skagit Public Utility District (PUD) a pressure control station at the intersection of N 9th Street and E Highland Avenue in Mt. Vernon, WA. The existing traditional pressure reducing valve (PRV) site is situated adjacent to the grounds of Mount Vernon High School, a Title I school. The project will install an ERV unit in a bypass configuration. Additionally, Level 1 and/or Level 2 electric vehicle chargers will be installed in an adjacent parking lot site. Energy produced will supply the EV chargers as well as building energy loads at the High School. This co-location positions the site to be an ideal case study showing how an ERV can act as a distributed energy source that provides highly beneficial clean energy with a consistent energy production profile to reduce costs and carbon emissions at educational EV charging and other types of local government facilities.

Tasks, Milestones, and Deliverables		Estimated Start/End Dates
<u>Milestone A: System Design and Permitting</u>		6/2024 to 9/2024
Task A.1	Design	6/2024 to 8/2024
	<ul style="list-style-type: none"> • Site/Civil Design, including site plan, location plan, foundation plan, and any concrete base and supports (as needed). • Electrical design, including overall site plan, cable routing and interconnection plan and a one-line diagram. • Mechanical layout, including inlet piping plan outlet piping plan, equipment specifications and enclosure design, and equipment support plan. 	
Task A.2	Regulatory permitting	7/2024 to 9/2024
	<ul style="list-style-type: none"> • FERC The demonstration meets the requirements for a Federal exemption from FERC licensing as a small conduit hydro project in an operating water pipeline. This activity includes completing the application to receive a FERC exemption. Note that the review and approval period is one-two months. • City/County Permits – Skagit PUD will apply for and submit documentation to receive any permits necessary for the successful completion of the project. • PSE Interconnection – This task includes the application for and submission documentation to receive an interconnection and net metering with Puget Sound Energy (PSE). 	
Budget	\$80,000	
Match	NA	
<u>Milestone B: Supply of Energy Recovery Device and Supporting Equipment</u>		8/2024 to 10/2024
Task B.1	Execution of purchase order for equipment	8/2024 to 8/2024
	<ul style="list-style-type: none"> • Procurement of all necessary equipment such as net meter, energy recovery unit, and EV charging station(s) 	
Task B.2	Receive Equipment	8/2024 to 10/2024

	<ul style="list-style-type: none"> Take possession of all necessary equipment such as net meter, energy recovery unit, and EV charging station(s) 	
Budget	\$488,800	
Match	\$11,200	
<u>Milestone C: Interconnection and Installation of Equipment</u>		10/2024 to 1/2025
Task C.1	Meter inter-connection	10/2024 to 12/2024
	<ul style="list-style-type: none"> Preparation for installation of the ERV equipment. This shall involve the demolition of existing piping and installation of a bypass in the existing Skagit PUD vault and construction of a concrete pad and other related infrastructure (as needed) to support the ERV system and controller. ERV electrical interconnection. This will include installation of electrical safety equipment, including a cut-off switch, conduit and the project electrical panel. This task includes trenching to the point of interconnection on the site of Mt. Vernon High School's electrical infrastructure. 	
Task C.2	Installation of equipment	11/2024 to 1/2025
	<ul style="list-style-type: none"> ERV installation. This shall include assembly of ERV components, placement in a protective enclosure, installation of mounting supports and installation of piping to integrate with the PRV bypass. Controls installation. This will include programming and installation of the system controller and related equipment. EV charging station installation. This shall involve installation of support equipment, mounting, and the electrical mounting equipment for EV charger (Level 1 or 2) Commissioning. This task will involve testing of equipment to assure the efficacy of the controls and equipment in a range of operating modes and the start of operations and energy delivery. 	
Budget	\$0	
Match	\$340,000	
<u>Milestone D: Analytics & Monitoring</u>		01/2025
Task D.1	Final Report	01/2025
	<ul style="list-style-type: none"> Skagit PUD to provide final report describing the accumulative project outcomes known to date Commerce to provide a fact sheet template to capture a summary of the project outcomes 	
Budget	\$30,000	
Match	\$0	
<u>Commerce Project Budget:</u>		\$598,800
<u>Project Match:</u>		\$351,200
<u>Total Project Budget:</u>		\$950,000

Attachment B: Budget

Milestone	Milestone and Task Description	Key Deliverable(s)	Activity Period	Percent of CEF Grant	\$ Applicant Match	\$ Amount of CEF Grant
A	System Design and Permitting					
A1	Design	Construction Plans and Electrical Drawings	6/2024 to 8/2024	12.5%	\$ -	\$ 75,000
A2	Regulatory Permitting	Completed and approved City and Electrical Permit, FERC Approval	7/2024 to 9/2024	0.8%	\$ -	\$ 5,000
Activity A Subtotal				13.4%	\$ -	\$ 80,000
B	Supply of Energy Recovery Device and Supporting Equipment					
B1	Execution of purchase order	Equipment Purchase Orders	8/2024 to 8/2024	61.4%	\$ -	\$ 367,500
B2	Receive Equipment	Order Delivery receipt and/or photos of received equipment	8/2024 to 10/2024	20.3%	\$ 11,200	\$ 121,300
Activity B Subtotal				81.6%	\$ 11,200	\$ 488,800
C	Interconnection and Installation of Equipment					
C1	Meter inter-connection	Documentation of interconnected net meter completion and/or video call with Commerce showing connection	10/2024 to 12/2024	0.0%	\$ 306,000	\$ -
C2	Installation of Equipment	Documentation of installation, Notification to operate, and/or Labor and Industries permit satisfaction	11/2024 to 1/2025	0.0%	\$ 34,000	\$ -
Activity C Subtotal				0.0%	\$ 340,000	\$ -
D	Analytics & Monitoring					
D1	Final Report	Final report to be provided by Skagit PUD describing project outcomes & Fact Sheet to be provided by Commerce containing a summary of the project	01/2025	5.0%	\$ -	\$ 30,000
Activity D Subtotal				5.0%	\$ -	\$ 30,000
Budget Total				100.0%	\$ 351,200	\$ 598,800
Total awarded amount						\$ 598,800

Attachment C: Reporting

The Contractor must provide quarterly written reports and/or host a regular quarterly video and/or phone call with COMMERCE for project update purposes. Phone contact should cover current status of the project and any barriers that are potentially affecting the project schedule.

The Contractor shall provide a quarterly report to COMMERCE, no later than 15 days after the end of each quarter. The report form will be provided by Commerce. The report should describe the project activity that occurred during the quarter, including but not limited to:

1. A narrative summarizing project activities, risks and issues mitigated, and lessons learned;
2. The project milestones met to date and anticipated in the subsequent quarter (such as through a project Gantt Chart schedule provided quarterly in Microsoft Project format showing actual progress to date along with the baseline schedule developed at project kickoff etc.); and,
3. Any additional metrics required from the capital budget proviso, legislature, governor's office, or COMMERCE.
4. Quarterly updated invoice projection sheet for grant expenditures. Commerce will provide the invoice projection sheet;

A final report and fact sheet will be submitted to Commerce. Commerce will provide the fact sheet template and may request the fact sheet be updated as conditions warrant.

Attachment D: Proviso

2021 Enacted Capital Budget

Substitute House Bill 1080, section 1064 – Clean Energy V

(14) \$4,900,000 of the state building construction account—state appropriation is provided solely for the department to develop targeted rural clean energy innovation projects as provided in this subsection (14).

(a) \$150,000 of the appropriation is provided solely for the department to develop targeted rural clean energy strategies informed by rural community and business engagement, outreach, and research. The department must convene a rural energy work group to identify investments, programs, and policy changes that align with the 2021 state energy strategy and increase access to clean energy opportunities in rural communities and agricultural and forestry management practices. The group must identify existing federal funding opportunities and strategies to leverage these funds with state capital investment. By June 30, 2022, the department shall report recommendations and findings from the rural energy work group to the office of financial management, the governor, and the appropriate legislative committees and present a strategic plan for state rural clean energy investment.

(b) \$4,750,000 of the appropriation is provided solely for rural clean energy innovation grants.

(i) The department must award at least 40 percent of the funding to projects that enhance the viability of dairy digester bioenergy projects through advanced resource recovery systems that produce renewable natural gas and value-added biofertilizers, reduce greenhouse gas emissions, and improve soil health and air and water quality.

(ii) Grants may also be awarded to other clean energy innovation projects in rural communities, including, but not limited to, projects that enhance energy efficiency, demand response, energy storage, renewable energy, beneficial electrification, resilience, organic waste management, and biological carbon sequestration.

(iii) Grants may fund project predevelopment, research, and development, pilot projects, strategic implementation, field trials, and data dashboards and tools to inform rural project development

(c) The department is encouraged to make 20 percent of the funds under (b) of this subsection (14) to tribal governments, designated subdivisions, and agencies.

(d) If a grant is awarded to purchase heating devices or systems, the agency must, whenever possible and most cost effective, select devices and systems that do not use fossil fuels.



1415 Freeway Drive | Mount Vernon, Washington 98273 | (360) 424-7104 | SkagitPUD.org

May 28, 2024

MEMORANDUM

TO: Board of Commissioners
FROM: Brian Henshaw
SUBJECT: Financial Hardship Assistance Application - *Discussion*

Requested Action:

Continue the discussion on high consumption events that are ineligible for a leak adjustment.

Background:

There have been a handful of large consumption events which were not eligible for an adjustment under the current policy. Staff was asked to develop a process and criteria to evaluate these events for possible consideration. For consideration is a financial assistance grant application that would be used to gather information on which to base a response.

Fiscal Impact:

Financial assistance grants would be reviewed and partial credits would be applied to customer accounts for high consumption events with extenuating circumstances. These funds would come from the PUD's operating expenses.

Enclosures: 1. [Hardship Assistance Application](#)

Financial Assistance Grant Application

Financial Assistance Grants are for Skagit Public Utility Customers who have experienced a high consumption event that did not qualify for a leak adjustment. The application is for customers to provide details on extenuating circumstances and/or information on the hardship that has resulted from the large bill. A partial credit may be provided to an account if the PUD deems just cause.

Before filling out an Assistance Grant Application, you must have completed the Leak Adjustment process with the PUD's Customer Service Department and been denied a credit. A copy of the Leak Adjustment Credit Application to must be submitted with the Financial Assistance Grant Application

The following questions are required for submitting your application for assistance.

Housing: Renter Owner

Income: Please indicate how many people live in your home and the total average monthly household income. Eligibility changes depending on the number of people in the household.

Number of People in Household? _____

Total Average Monthly Household Income? _____

Are you or a member of your household eligible for the county senior citizen and people with disabilities exemption from real property taxes? Yes No

Are you or a member of your household disabled? Yes No

Are you or a member of your household a veteran? Yes No

Please answer the following questions and provide as much detail and explanation as possible to describe the circumstances around your high consumption event. Please include photos, receipts, invoices, and any other documentation that can be used to assess your situation. You may attach as many pages as necessary to fully answer the questions and provide the requested information.

Questions to consider:

- Please describe, in detail, all of the important events that led to the high consumption event.
- Please describe what steps have been taken since the event to ensure that it does not happen again.
- What other information is important for the PUD to know when considering this application?
- How long have you resided at the address that had the event?
- If you are a tenant, have you contacted your landlord to request assistance? If yes, what was the response?

- Have you reached out to any other community organizations and requested assistance?
- Will you consider a monthly payment plan to pay off the outstanding balance?
- What plans are in place if you do not receive a credit?

I SWEAR UNDER PENALTY OF PERJURY UNDER THE LAWS OF THE STATE OF WASHINGTON THAT THE FOREGOING IS TRUE AND CORRECT TO THE BEST OF MY KNOWLEDGE AND BELIEF.

SIGNED AND ATTESTED AS TRUE, as of the date set forth below:

Customer Signature

Print Name: _____

Date: _____



1415 Freeway Drive | Mount Vernon, Washington 98273 | (360) 424-7104 | SkagitPUD.org

May 28, 2024

MEMORANDUM

TO: Board of Commissioners
FROM: George Sidhu, P.E., General Manager
SUBJECT: Public Records Act Resolution, Policy, and AP&P - *Action*

Requested Action:

Approve Resolution No. 2305-24 relating to the Public Records Act (PRA) and authorize the general manager to sign Policy #1033, *Public Records Act and Disclosure*.

Background:

Existing resolutions 2238-16 and 2250-17 address the guidelines for inspection and copying of all the PUD's public records. Since those resolutions were approved, there have been updates and changes to RCW 42.56 Public Records Act and this new Resolution 2305-24 provides the updates. To ensure and enforce compliance with the Public Records Act, the PUD is proposing to update the resolution to create and adopt a formal policy (Policy #1033) establishing rules and requirements for how a request for public records can be made, the fees for copies and fee determination, when requests are closed, withdrawn, or considered abandoned, and how the PUD determines what records or information is exempt and withheld.

A new Administrative Practice and Procedure (AP&P #2050) has also been created to detail how PUD staff will conduct public record requests.

The updated resolution and new policy requires Board review and approval and the AP&P is also provided for review and comment.

Fiscal Impact:

No financial impact of these changes is anticipated.

- Enclosures:
1. [Resolution #2238-16](#)
 2. [Resolution #2250-17](#)
 3. [DRAFT Resolution #2305-24 Public Records Act](#)
 4. [DRAFT Policy #1033 Public Records Act and Disclosure](#)
 5. [DRAFT AP&P #2050 Public Records Act and Disclosure](#)

RESOLUTION NO. 2238-16

A RESOLUTION OF THE COMMISSION OF PUBLIC UTILITY DISTRICT NO. 1 OF SKAGIT COUNTY, WASHINGTON, RELATING TO PUBLIC RECORDS AND DISTRICT POLICY.

BE IT RESOLVED BY THE COMMISSION OF PUBLIC UTILITY DISTRICT NO. 1 OF SKAGIT COUNTY, WASHINGTON, as follows:

Section 1 RECITALS AND FINDINGS.

1.1 The District is subject to Washington Public Records Act at Chapter 42.56 RCW. The Public Records Act is frequently referred to as the "PRA."

1.2 Over 25 years' ago, the District established its PRA policy, at Resolution No. 1530-90, now superseded by Resolution No. 1712-96 (April 30, 1996). The District has further addressed PRA issues in its Policy on Governance and Management.

1.3 PRA law has evolved over time, including its application to public records that may be on personnel computers or communications devices (such as smart phones). For example, our Supreme Court holds that text messages on personal devices may be public records and required to be maintained and released in response to a public records request (or, "PRR"). *Nissen v. Pierce County*, 183 Wn.2d 863 (2015).

1.4 The District is dealing with this emerging issue and PRRs for records on personal devices. Issues have arisen regarding District responses regarding public records that may exist on a personal device of a District officer or employee.

1.6 The purpose of this Resolution is to clarify and provide for management of responses to PRRs and the conduct of individual officers and employees.

Section 2. DISTRICT PUBLIC RECORDS POLICY SUPPLEMENTED.

2.1 The District public records policy is clarified and updated by this Resolution.

2.2 All officers and employees of the District, including elected officials, must retain and produce public records within their control consistent with the PRA, including records on personal devices such as lap top computers, tablets, phones and other devices. As a result, and to the fullest extent practicable, records are to be on the District's system. For example, all officers and employees have individual District email addresses and that address shall be used for emails and related communications that are public records. Records (that are public records) received on personal devices are to be forwarded to the District for record maintenance before destruction, and in any event within twenty one (21) days of receipt of a request. A public record on a personal device may be deleted only if such destruction complies with the State's Record Retention Schedule (which in most cases is 6 years), or transferred to the District for retention or destruction.

2.3 Any record subject to a PRR shall not be destroyed until first produced by each officer and employee to the District for review. Upon review, the District may determine that the record is not responsive; or, the record is responsive and either (1) produce the record consistent with the PRA, or (2) withhold or redact the record with appropriate exemption log under the PRA. Because of the limited capacity and transitive nature of text messages on many mobile devices, the District's policy is to transcribe any text messages (requiring retention) from mobile device(s) and save the records in electronic form so they can be retained in electronic and/or paper form. Once the requested text messages are transcribed and saved, the District's policy permits the removal of text messages that may be public records from personal device(s).

2.4 Upon request from an officer or employee, the District will review personal devices of the officer or employee for public records. The cost of the review shall be the responsibility of the District, including if necessary the cost of an outside forensic investigation of the device. The District will not be responsible for individual

officer and employee expenses that are not incurred or authorized by the District (including but not limited to expenses arising out of an officer or employee failing to produce records on personal devices or otherwise failing to cooperate with the District in responding to a PRA request).

2.5 The District bears no responsibility for an employee's or officer's failure to comply with the PRA or this Resolution that subjects the employee or officer to remedies under the PRA. An intentional violation of the PRA or this Resolution may also result in the denial of District defense and/or indemnification under the District's policies.

Section 3. EFFECTIVE DATE AND APPLICATION.

3.1 This Resolution shall take effect and be in force immediately on its adoption, and applies to any public record (now or in the future) on a personal device of an officer or employee; and, further applies to any pending PRR.

3.2 Consistent with Resolution No. 1712-96, the General Manger remains responsible for monitoring and enforcement of this Resolution. In the case of absence or disqualification of the General Manager, the Clerk of the Board shall be responsible.

3.3 In recognition of the limited resources available to the District, the District reserves the right to prioritize responses to PRRs, such as responding to simpler PRRs prior to the District's response to earlier PRRs that are more extensive and difficult to address.

ADOPTED by the Commission of Public Utility District No. 1 of Skagit County, Washington, at a regular open public meeting thereof this 11th day of October, 2016.



ATTEST

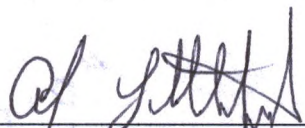

Al Littlefield, President

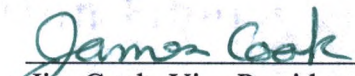

Jim Cook, Vice President

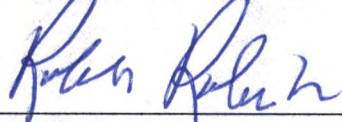

Robbie Robertson, Secretary

RESOLUTION NO. 2250-17

A RESOLUTION OF THE COMMISSION OF PUBLIC UTILITY DISTRICT NO. 1 OF SKAGIT COUNTY, WASHINGTON, ESTABLISHING POLICY FOR PUBLIC INSPECTION AND COPYING OF ALL THE DISTRICT'S PUBLIC RECORDS.

WHEREAS, Public Utility District No. 1 of Skagit County (the "District") is a municipal corporation, organized under the laws of the State of Washington. The governing board consists of three elected commissioners. Each commissioner serves for a six-year term and a commissioner position is on the election ballot every two years, and

WHEREAS, The Board of Commissioners establishes policy and appoints a General Manager who is charged with the responsibility of operating the District within the guidelines established. The Board of Commissioners meets regularly on the second and fourth Tuesday of each month and rules of procedure are established by resolutions of the Board at those meetings, and

WHEREAS, Public Utility District No. 1 of Skagit County is engaged in the transmission of municipal and industrial water throughout certain areas of Skagit County in the State of Washington, and

WHEREAS, the main office of the District is located at 1415 Freeway Drive, Mount Vernon, Washington. The operation of the District is directed from the main office. The established place where information may be made available to the public is at the aforesaid location, and the person from whom authority to obtain such information is the General Manager. Information will be made available to those parties who make such request for specific information in writing either in person or by mail, and

WHEREAS, given District staffing levels and the District's efforts to maintain competitive utility rates, the Board of Commissioners finds that maintaining an index of District documents would be unduly burdensome, nonetheless, the Minute Book has been designated as the Official Record of the District wherein the following items may be found: Final opinions of the Board; statements of policy; interpretations of policy; administrative staff instructions, as well as the planning policy and goals, and

WHEREAS, adequate District facilities are available at the District's office for the purpose of copying public records requested by the public. While no fee shall be charged for the inspection of public records, there will be a charge established for copying, and

WHEREAS, from time to time requests are made to inspect and copy public records of the District, and

WHEREAS, the Commission recognizes the need for specific guidelines and requirements for public inspection and copying of public records, unless the record falls within the specific exemptions of Chapter 42.56.070(8), 42.56.210 and 42.56.230-480 RCW, or other statutes which exempt or prohibit public disclosure of specific information or records, and

WHEREAS, it is understood that legal counsel may be sought in certain circumstances to determine whether or not requests fall within statutory exemptions or prohibitions.

NOW, THEREFORE, BE IT RESOLVED that the Commission finds to be fair, reasonable, necessary, and in the public interest and hereby adopts the following guidelines for the District:

1. The District will provide forms for the requestor's use.
2. The requestor will be required to fill out the form, or submit a request in person, by mail, email, fax, or over the telephone.
3. The District's clerk(s) will assign a number to the request.
4. Within five business days of the District's receipt of a request for a public record, the District will either (1) provide the record, (2) acknowledge receipt of the request and provide an estimate of the time to respond, including but not limited to the time necessary to determine whether all or portion of the public records requested are exempt from disclosure under applicable statutes, or (3) deny the disclosure request, stating the exemption on which the District based its decision.
5. The request form will be routed for approval or denial.

6. Upon approval/denial, (by mail if necessary) a copy of the request will be returned to the requestor. An estimate of the cost may be provided if requested by the requestor.
7. The routing copy will be used to initiate work. When the work is completed, the routing copy will be used to notify Accounting of the fee.
8. Fees will be assessed pursuant to Chapter 42.56.070(7) and 42.56.120 (1-4) RCW, and include the following:
 - a. A charge of fifteen cents (\$0.15) per page for photocopies of public records, printed copies of electronic public records when requested by the person requesting records, or for the use of agency equipment to photocopy public records.
 - b. A charge of ten cents (\$0.10) for public records scanned into an electronic format or for the use; five cents (\$0.05) per each four electronic files or attachment uploaded to email, cloud-based data storage service, or other means of electronic delivery, and ten cents (\$0.10) per gigabyte for the transmission of public records in an electronic format to send the records electronically. The charges identified in this subsection may be combined to the extent that more than one type of charge applies to copies produced in response to a particular request.
 - c. The District may charge a flat fee up to two dollars (\$2.00) for any request as an alternative to fees authorized under RCW 42.56.120 (1) or (b) when it reasonably estimated and documents that the costs allowed are clearly equal to or more than two dollars.
 - d. The actual cost of any digital storage media or device provided by the District, the actual cost of any container or envelope used to mail the copies to the requestor, and the actual postage or delivery charge.
 - e. In addition to the charge imposed for providing copies of public records, the District may include a customized service charge. A customized service charge may only be imposed if the District estimates that the request would require the use of information technology expertise to prepare data compilations, or provide customized electronic access services when such compilations and customized access service are not used by the District for other District purposes. The customized service charge may reimburse the District up to the actual cost of providing the services under this subsection.
 - f. Whenever charges are required, such charges must be paid in full by the requestor prior to receiving copies of the public records.
9. Public records will be made available for inspection and copying during the customary office hours of the District which are Monday through Friday, excluding holidays, 8:00 AM through 5:00 PM.

BE IT FURTHER RESOLVED, that this resolution shall supersede Resolution No. 1712-96.

ADOPTED by the Commission of Public Utility District No. 1 of Skagit County, Washington, at a regular meeting held this 24th day of October, 2017.



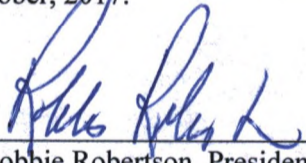

 Robbie Robertson, President

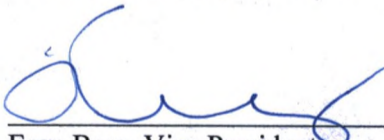

 Eron Berg, Vice President

ATTEST 

 Al Littlefield, Secretary

RESOLUTION NO. 2305-24

A RESOLUTION OF THE COMMISSION OF PUBLIC UTILITY DISTRICT NO. 1 OF SKAGIT COUNTY, WASHINGTON, RELATING TO THE PUBLIC RECORDS ACT (PRA)

WHEREAS, Public Utility District No. 1 of Skagit County (the “District”) is a municipal corporation, organized under the laws of the State of Washington; and

WHEREAS, RCW 42.56 requires the District to make available to the public any and all identifiable public PUD records, subject only to the exemptions and prohibitions under RCW 42.56.070; and

WHEREAS, the Public Records Act requires the District to adopt a Public Records Act Policy which outlines its procedures and methods whereby the public may obtain information, make submittals or requests, or obtain copies; and

WHEREAS, the Public Records Act requires the District to assign a Public Records Officer; and

WHEREAS, the Public Records Act requires the District to adopt a fee schedule; and

WHEREAS, it is understood that legal counsel may be sought in certain circumstances to determine whether requests fall within statutory exemptions or prohibitions.

NOW, THEREFORE, BE IT RESOLVED that:

The District adopts Policy 1033, establishing rules and requirements for compliance with the Public Records Act; and

The Public Records Officer (PRO) is the Clerk of the Board. In the Clerk’s absence, the General Manager shall serve as the PRO; and

Adopts the following fee schedule for instances requiring a fee as outlined in RCW 42.56.120.

The District reserves the right to waive fees for requests from other governmental agencies.

BE IT FURTHER RESOLVED, that this resolution shall supersede Resolution No. 2238-16 and No. 2250-17.

ADOPTED by the Commission of Public Utility District No. 1 of Skagit County, Washington, at a regular meeting held this ____ day of _____, 2024.

Joe Lindquist, President

Andrew Miller, Vice President

ATTEST

Corrin Hamburg, Secretary



Public Records Act and Disclosure Policy #1033

In accordance with the authority granted by Board Resolution #2305-24, a Public Records Act and Disclosure Policy, as described below, is hereby established for Public Utility District No. 1 of Skagit County.

Purpose:

The purpose of this policy is to establish rules and requirements for compliance with the Public Records Act. Procedures that the District will follow in order to provide full access to public records are outlined in AP&P #2050.

Public Records Act:

The Public Records Act, RCW 42.56, requires that all public records maintained by the District be made available for inspection and copying "public records" in accordance with published rules. The purpose of the act is to provide the public full access to information concerning the conduct of government, mindful of individuals' privacy rights and the desirability of the efficient administration of government.

It is the policy of Skagit Public Utility District No. 1 to ensure access to public records without discrimination and to provide appropriate safeguards for information exempted or prohibited from disclosure by statute.

What Records are Public:

A public record is any writing that is prepared, owned, used, or retained by the District and which contains information that relates to the conduct of government or the performance of any governmental or proprietary function. The term "writing" is broadly defined to include not only traditional written records but also photos, maps, videos, audio recordings, voicemails, emails, and text messages.

Public Records Officer:

The District's Public Records Officer (PRO) is the Clerk of the Board. The PRO will oversee compliance with the Act, but other District staff may process requests. The PRO may be contacted at pr@skagitpud.org or by calling 360-848-7104. In the absence of the Clerk, requests can be made to the General Manager.

Public Record Requests:

Any person wishing to inspect or copy public records of the District shall make the request to the Public Records Officer. Public records are available for inspection during the District's regular

business hours, which are Monday through Friday from 8 a.m. to 5 p.m., excluding District holidays. Records may not be removed from District property.

Requests can be made:

In person/mail: 1415 Freeway Drive, Mount Vernon, WA 98273
By email: pr@skagitpub.org
By phone: by calling 360-848-4460

The request should include the following with sufficient information to allow us to communicate with the requester and provide sufficient information to allow the District to readily identify the record or records requested:

1. Name of requester
2. Full address of requester
3. Telephone number of requester
4. Email address of requester
5. Date and time of request
6. A complete description of the requested record
7. The title and date of the requested record, if known
8. The location of the requested record, if known

Fees

If the requester wishes to have physical or electronic copies of the records made instead of simply inspecting them, the requester should so indicate. The requester will be required to pay any production fees and charges as set forth in RCW 42.56.120 in full prior to receiving copies of the public records:

Photocopies	\$0.15 per page side
Scanned paper documents	\$0.10 per page side
Electronic files	\$0.05 for every 4 files
Electronic files over 1 gigabyte	\$0.10 per gigabyte
Electronic storage media (USB, CD, etc)	Actual media costs

The District may charge the actual costs of providing public records, which may include the actual costs of providing photocopies, all costs “directly incident” to shipping or mailing the records, including postage and delivery charges, and the cost of any container or envelope used, and staff time to copy and mail the requested public records.

In addition to the fee for providing copies, the District may include a customized service charge if the request would require the use of information technology expertise to prepare data compilations or customized electronic access services when such compilations and customized

access services are not used by the District for other District purposes. The requester will be notified in advance of the reasons for the customized service charge and an estimate of the costs.

Whenever charges are required, the requester must pay them in full before receiving copies of the public records.

The District reserves the right to waive fees for requests from other governmental agencies.

Fee Determination

No fee will be charged for:

- The inspection of a public record
- The record(s) is found on the District's website.

Fees will be waived when:

- A records request is made by a federal, state, or local agency, or
- The total fees of paper copies or scanned pages amount to \$10.00 or less, including the cost of envelope, container, or device, and postage as necessary, or
- All responsive records are electronic and can be provided in one email or a shared link.

No sales tax will be charged.

Deposit

For large requests, the PUD may require a deposit of ten percent (10%) of the estimated total.

Closing, Withdrawn, or Abandoned Requests

If the requestor withdraws the records request, fails to clarify a request when asked, fails to inspect the records within 15 business days of notice that the records are available for inspection, or fails to pay the deposit or final payment for the requested copies, the records request shall be deemed abandoned and closed. The requestor will be notified that the request has been closed and that no further action will be taken.

Compliance:

This policy applies to all employees, Commissioners, and any applicable third-party record holders and covers all District public records. All employees are expected to have a general knowledge and understanding of the PRA, and, when requested, assist in the disclosure process in an efficient and cooperative manner. Applicable employees will be provided training on public records request processing requirements.

Records Exempt from Public Disclosure:

The District reserves the right to determine whether a public record, or portion thereof, is exempt from disclosure under the Act or other applicable law, and to withhold such record, or portion thereof, from disclosure and/or copying.

If any record, in whole or in part, is determined to be exempt from disclosure, the District shall provide the requester with a written statement of the specific exemption authorizing the

withholding of the record and shall provide a brief explanation of how the exemption applies to the record withheld.

The District will not provide or sell public records for private gain or commercial purposes. A requester will not be asked to disclose the purpose of the request, with two exceptions:

- 1) If the request is for a list of individuals, the requester will be required to fill out an affidavit relating to commercial purpose usage. Records will not be produced until an affidavit is provided to the District if it is determined that a commercial purpose may exist. The District, by law, is prohibited from disclosing public records lists for individuals when the intent is to use the information for commercial purposes.
- 2) A requester may be asked the purpose of the request only if such information will sufficiently allow a determination if another statute prohibits disclosure.

Former Title/Policy #:	
Board Approval Date:	
Effective Date:	
Revision Date: N/A	
General Manager Signature:	Date:



Public Records Act (PRA) and Disclosure Administrative Practice & Procedure #2050

As outlined in District Policy #1033, this Administrative Practice & Procedure (AP&P) sets forth the standard procedures for the District's handling of public record requests (also known as public disclosure requests). This AP&P does not apply to discovery requests made in conjunction with litigation, subpoenas, or other legal proceedings.

Public Record Requests:

Any record subject to a public records request shall not be destroyed until reviewed by the District. The District may determine that the record is not responsive or the record is responsive and either (1) produce the record or (2) withhold or redact the record with the appropriate exemption log.

In the event a request is overly broad, the District may seek clarification, ask the requester to prioritize the request so that the most important records are provided first, and/or communicate with the requester to limit the size and complexity of the request. The District may also provide the responsive records in installments over time. When a request uses an inexact phrase such as "all records relating to" and declines to clarify the scope of the request, the PRO may interpret the request to be for records that directly and fairly pertain to the topic. The phrase is inherently ambiguous, and requesters are encouraged to avoid using the phrase when possible to avoid unnecessary delays. When the requester has found the record(s) they are seeking, the requester should advise the PRO that the requested records have been provided and the remainder of the request may be canceled.

Records requests may only encompass existing records. They cannot be used to obtain copies of records not yet in existence. The District is not obligated to create a new record to satisfy a records request. However, the District may, at its discretion, create such a new record to fulfill the request where it may be easier to create a record responsive to the request than to collect and make available voluminous records that contain small pieces of information responsive to the request. In addition, the District is not obligated to hold current records requests open to respond to a request for records that may be created in the future. If a public record is created or comes into the possession of the District after a request is received by the District, it is not responsive to the request and will not be provided. A new request must be made to obtain later-created public records.

Processing Requests:

Within five (5) business days of the District's receipt of a request for a public record, the District will either:

1. Provide the record, or
2. Acknowledge receipt of the request and provide a reasonable estimate of when records will be provided, or
3. Seek clarification, or
4. Deny the request.

The District may respond to a request using one of the methods below to provide the requestor access to the record(s):

- Provide access to records for in-person review;
- A link to the District's website containing an electronic copy of the record;
- For large requests: a OneDrive link to the folder containing the records or an electronic memory stick with the requested records;
- For small requests: an email attachment.

In no event will the District allow a requester to bring their own portable device and connect to the District's network.

The PRO should be consulted prior to responding to a request, Cc'd in all email communications, or provided with a copy of communications along with access to the record(s) provided.

Additional time to provide access to records may be needed to clarify the scope of the request, locate and assemble the records, redact confidential information, prepare an exemption log, notify third-party persons or agencies affected by the request or consult with the District's Attorney about whether any portion of the records is exempt from disclosure. Should an extension of time be necessary to fulfill the request, the PRO will provide a revised estimate and explain the changed circumstances that make it necessary.

Should clarification be required, the PRO will contact the requestor in writing, asking that clarification be provided within five (5) business days. Any such correspondence will include the warning that failure to respond will result in the PRO considering unclear portions of the request abandoned per RCW 42.56.520(3).

The District will conduct a reasonable search for responsive records and will notify the requester if records are available and of any associated fees. The requester has 15 business days to either review the records or pay any charges and pick up the documents they requested. The request will be considered abandoned and administratively closed without further communication to the Requestor if the requester does not review or pick up the requested documents within those 15 days. Once an inspection has been completed or copies provided, the PRO will indicate that the request is closed, and no further action will be taken by the District.

All employees of the District, including elected officials, must retain and produce public records that are consistent with the PRA and within their control, including records on personal devices such as laptop computers, tablets, phones, and other devices. When requested and in a timely fashion, all employees will search records within their area of responsibility and track and report to the PRO the staff time expended in searching and responding.

Employees should be aware that work-related text messages on both personal and work cell phones are public records subject to the PRA. Employees have a duty to maintain such records and should consult with their Supervisor or the PRO on effective ways of transferring the message(s) to the District's network.

If the District does not respond in writing within five (5) business days of receipt of the request, the requester should contact the PRO to determine the reason.

Some records are exempt, in whole or in part, from disclosure. If the District believes that a record is exempt and should be withheld, the PRO will state the specific exemption in a log and provide a brief explanation of why the record of a portion thereof is being withheld. If only a portion of a record is exempt from disclosure, but the remainder is not exempt, the PRO will redact the exempt portions, provide the nonexempt portions, and indicate to the requester why portions of the record are being redacted.

Notice to Third Parties:

If the requested records contain information that may affect the rights of others and/or may be exempt from disclosure, the District may notify that individual or organization to allow the third party to seek relief pursuant to RCW 42.56.540. The District may take this into account when providing an estimate for when the records will be available. The notice to the affected person(s) may include a copy of the request.

Review of Denials of Records:

Any person who objects to the denial of a request for a public record may petition for prompt review of such denial by tendering a written request for review to the Public Records Officer. The request shall specifically refer to the written reason for denial. The District will review the decision and either affirm or reverse the denial by the end of the second business day following receipt of the written request for review.

The requestor has the right to seek judicial review in the appropriate legal venue.

Index of Public Records:

Maintaining an index of District records is unduly burdensome, costly, and would interfere with District operations due to the number and complexity of records generated. The District, however, maintains an index of Resolutions adopted by the Board of Commissioners, which is available on the website and/or may be requested from the Public Records Officer.

Disclaimer of Liability:

Neither the District nor any elected official or employee shall be liable, nor shall a cause of action exist, for any loss or damage based on a release of Public Records if the person releasing the records acted in good faith in attempting to comply with the Public Records Act.

This policy is not intended to expand or restrict the rights of disclosure or privacy as they exist under state and federal law. Despite the use of any mandatory terms such as “shall,” nothing in this policy is intended to impose mandatory duties on the District beyond those imposed by state and federal law.

Former Title/Policy #:	
Board Approval Date:	
Effective Date:	
Revision Date: N/A	
General Manager Signature:	Date:



1415 Freeway Drive | Mount Vernon, Washington 98273 | (360) 424-7104 | SkagitPUD.org

May 28, 2024

MEMORANDUM

TO: Board of Commissioners
FROM: George Sidhu, P.E., General Manager
SUBJECT: SkagitNet Resolution No. 24-10, Concerning Banking and Amending Operating Agreement - *Action*

Requested Action:

Approve SkagitNet Resolution No. 24-10, concerning banking and amending operating agreement.

Background:

Resolution No. 23-01 approved in June, 2023, designated the Chief Financial Officer, Port of Skagit County, as Treasurer and Authorized Agent of SkagitNet LLC to endorse and make deposits, sign checks, withdraw funds and otherwise operate such accounts on behalf of the company. This new Resolution No. 24-01 supersedes the previous resolution and changes the authority to the highest ranking staff member in the Port of Skagit County's finance department, or his/her designee.

Fiscal Impact:

None.

Enclosures: 1. [SkagitNet Resolution 24-10](#)

SKAGITNET, LLC

RESOLUTION No. 24 - 10

A RESOLUTION CONCERNING BANKING AND AMENDING OPERATING AGREEMENT

WHEREAS, SkagitNet, LLC (the “**Company**”) is legally organized in and pursuant to the laws of the State of Washington.

WHEREAS, the Members of the Company, adopted by this resolution at a meeting of each member where notice was proper, and quorum was met in accordance with applicable state law and all Company rules; and

WHEREAS, the Members have determined that opening one or more bank accounts at Banner Bank is in the Company's best interests; and

WHEREAS, the Members have decided that the highest ranking staff member in the Port of Skagit County’s finance department, or his/her designee, acting on behalf the Company as the Treasurer, be given signature authority on the Company’s bank accounts;

NOW, THEREFORE, THE FOLLOWING IS RESOLVED:

1. The Company is authorized to establish one or more accounts with Banner Bank (the “**Institution**”), which includes, but is not limited to, maintaining and funding savings, checking, and other financial accounts required for the Company to do business.
2. The Agreement is hereby amended as follows:
 - a. Section 3.1. (b) is hereby amended to read in its entirety as follows:

The highest ranking staff member in the Port of Skagit County’s finance department (“**Treasurer**”), or his/her designee, serving as the custodian of funds made available for the purposes of such telecommunication services and that the Treasurer may make payments from NETWORK funds in its possession upon approval of the Manager and audits by the appropriate auditing officer of the PUD; *provided*, that the funds held by the Treasurer shall not be co-mingled with the funds of any Member and shall be separately accounted for as owned exclusively by SkagitNet.

3. The following Company agent (the "**Authorized Agent**"), or his/her designee, is authorized to endorse and make deposits, sign checks, withdraw funds, and otherwise operate such account on behalf of the Company:

The highest-ranking staff member in the Port of Skagit County's finance department, Port of Skagit County, Treasurer.

That person then currently designated as acting Manager by the Executive Director of the Port of Skagit County after conferring with the General Manager of Skagit PUD.

4. The Authorized Agent may not borrow money or obtain credit on the Company's behalf.
5. The Company records shall be updated with this Resolution and this Resolution shall be presented to the Institution, as appropriate.
6. The Manager is hereby authorized to take all necessary and reasonable actions required to carry out this Resolution.
7. This Resolution may be executed in counterparts. Facsimile or scanned signatures are binding and are considered to be original signatures.
8. This Resolution is adopted by the Members as follows: Port of Skagit County on May 7, 2024; and Skagit County PUD No. 1 on May 28, 2024, and shall be immediately effective upon adoption by both Members.

[SIGNATURE PAGES TO FOLLOW]

CERTIFICATE OF MEMBER ACTION AND RESOLUTION

I, Steve Omdal, duly elected and qualified Commission Secretary, hereby certify that the attached is a true, correct, and complete copy of the Resolution that was duly adopted at a meeting of the Port of Skagit County on May 7, 2024.

I further certify that the aforementioned Resolution is now in full force and effect without modification or rescission.

Signed this 7th day of May 7, 2024.

Signature:  _____

CERTIFICATE OF MEMBER ACTION AND RESOLUTION

I, Corrin Hamburg, duly elected and qualified Commission Secretary, hereby certify that the attached is a true, correct, and complete copy of the Resolution that was duly adopted at a meeting of the Skagit County PUD No. 1 on _____, 2024.

I further certify that the aforementioned Resolution is now in full force and effect without modification or rescission.

Signed this _____ day of _____, 2024.

Signature: _____

COMMISSION, PORT OF SKAGIT COUNTY

Mahlon B. Hull
Mahlon Hull, Commission President

May 7, 2024
Date

Steve Omdal
Steve Omdal, Commission Secretary

May 7, 2024
Date

Kevin Ware
Kevin Ware, Commissioner

May 7, 2024
Date

COMMISSION, SKAGIT COUNTY PUBLIC UTILITY DISTRICT No. 1

Joe Lindquist, Commission President

Date

Andrew Miller, Commission Vice President

Date

Corrin Hamburg, Commissioner Secretary

Date



1415 Freeway Drive | Mount Vernon, Washington 98273 | (360) 424-7104 | SkagitPUD.org

May 28, 2024

MEMORANDUM

TO: George Sidhu, P.E., General Manager

FROM: Mark Handzlik, P.E., Engineering Manager

SUBJECT: Pipeline Relocation Projects on SR-20 at Olson Creek and SR-9 North of Kalloch Road, Change Order 01 - Action

Requested Action:

Authorize the general manager to approve Change Order 01 with Earthwork Solutions, LLC in the amount of \$221,577.14 for additional HDD services at the SR20 Olsen Creek waterline relocation project.

Background:

On February 2, 2024, with the approval of the board, the general manager executed a contract with Earthwork Solutions, LLC (EWS) in the amount of \$800,531.05 for the construction of Pipeline Relocation Projects on SR-20 at Olson Creek and SR-9 North of Kalloch Road.

Construction of these pipeline relocation projects will facilitate fish passage (culvert replacement) projects required of WSDOT. Both projects involve horizontal directional drilling (HDD) as the primary method of pipeline installation. Per the schedule, as dictated by WSDOT, relocation at SR-20 is the priority project and that is where work has begun.

HDD activities began on March 18th and by mid-day, Sound Drilling (EWS subcontractor) encountered an obstruction which caused the pilot drilling to come to a halt. Sound Drilling intended to use conventional drilling method for the soil conditions shown in the bore logs at bid time. With the rock obstruction being ~200 in length, Sound Drilling acquired a pneumatic hammer and compressor to drill through the obstruction to continue progress onsite.

The change order will cover expenses to date and provide for additional time to increase the bore hole larger than originally planned.

Fiscal Impact:

This change will increase the contract amount by \$221,577.14. The current budget for SR-9 and SR-20 combined is \$975,000.000, of which \$582,000 is offset through State funding. The current actual spent funds plus committed funds for SR-9 and SR-20 combined is \$864,172.21, leaving a balance of \$110,827.79. Final adjustments to the overall 2024 capital budget will be made prior to fiscal year end 2024 to remain within spending limitations authorized by the commission.

- Enclosures:
- 1. [Change Order 01](#)
 - 2. [COP 001 Rock Drilling](#)



Change Order No. 1

		17-Apr-24	
Project Name:		Pipeline Relocation at SR-20 and SR-9	
Owner:	Skagit PUD No. 1	Contractor:	Earthwork Solutions, LLC
		Attention:	Pavel Nikolin President
Address:	1415 Freeway Drive Mount Vernon, WA 98273	Address:	8629 156th St NE Arlington, WA 98223

Original Contract Amount (incl. Tax):	\$	800,531.05	Days	
Previously Approved Changes (incl. Tax)	\$	-	Days	
Total Before This Change Order:	\$	800,531.05	Days	0
This Change Order (incl. Tax):	\$	221,577.14	Days	0
New Contract Amount (incl. Tax):	\$	1,022,108.19	Days	0
Original Substantial Completion Date:	Wednesday, April 24, 2024			
New Substantial Completion Date:	Friday, May 24, 2024			

This Change Order covers the contract modification hereunder described. All other terms and conditions remain unchanged.

Description of Changes	Bid Item Amount		Time Change in Days
	Increase in Dollars	Decrease in Dollars	
Rock Refusal Section from STA 39+15 to 37+80 (SD)	\$ 112,265.53		
Additional Field Supervision and Equipment for 4 weeks Foreman w/ 1-Ton (20 Hours), Superintendent w/ Truck	\$ 14,726.40		
Shoring Rental 1 Month	\$ 3,425.91		
Rock over reaming from STA 39+15 to 37+80 (SD)	\$ 47,000.00		
Markup (15%)	\$ 26,612.68		
Totals	\$ 204,030.52		

Total This Change w/o Tax	\$	204,030.52
Total Tax 8.60%	\$	17,546.62
Total This Change with Tax	\$	221,577.14
Contract Total to Date	\$	1,022,108.19

With this Change Order, the Contract Amount shall be increased (decreased) by the sum of \$ 221,577.14 and the Contract Time shall be extended until May 24, 2024.

Skagit PUD reserves the right to deduct a portion of the payment from A12 for the pilot hole from STA 39+15 to

37+80.

It is understood and agreed that the acceptance of this Change Order by the Contractor constitutes an accord and satisfaction and represents payment in full both as to time and money for all costs arising out of, or incidental to, the above described change to the Contract including any and all delay and impact resulting from this change in Work.

Earthwork Solutions, LLC

By: Pavel Nikolin

Title: President

Date: _____

Signature: _____

Change Order Proposal

8629 156th ST NE
Arlington, WA 98223
(425) 422 - 3825

Contractor:	Earthwork Solutions, LLC.
Customer:	Skagit Public Utility District
Address:	1415 Freeway Drive
City, State Zip:	Mount Vernon, WA 98273
Phone:	(360) 424-7104
Project:	Pipeline Relocation SR20 & SR9

Date: 4/17/2024

Rock Refusal Section from STA 39+15 to 37+80 (Sound Drilling)	\$ 112,265.53	
Additional Field Supervision and Equipment for 4 weeks	\$ 15,000.00	\$14,726.40
Foreman w/ 1-Ton (20 Hours), Superintendent w/ Truck (20 Hours)		
Shoring Rental 1 Month	\$ 3,425.00	.91
Overtime Premium for Flagging (40 hours)	\$ 1,000.00	
Rock over reaming from STA 39+15 to 37+80 (Sound Drilling)	\$ 47,000.00	

Flagging overtime moved to contract flagging hours

Mark-up (15%)	\$ 26,803.58	\$26,612.68
Proposal in the amount of	\$ 205,494.11	\$204,030.52

ACCEPTED: The above prices and above specifications of the proposal are satisfactory and are hereby accepted.

Owner signature below serves as acknowledgment to execute an agreement for work covered by this proposal, bid documents, and other contract documents. Contractor signature below serves as acknowledgement that bidder understands bid documents and appendicitis. Contractor acknowledges that owner reserves the right to accept or reject any and all bids without cause.

Accepted By:

Mark Handzlik
Skagit PUD

Date

Pavel Nikolin
President
Earthwork Solutions, LLC.

Date

INVOICE

Sound Drilling LLC

24499 east state street
Sedro Woolley, WA 98284

kolton@sounddrillingllc.com

+1 (425) 244-2303

www.sounddrillingllc.com

Josh Frizzell

Bill to

Josh Frizzell
Earthwork Solutions, LLC
8629 156TH ST NE
ARLINGTON, WA 982236111 USA

Ship to

Josh Frizzell
Earthwork Solutions, LLC
8629 156TH ST NE
ARLINGTON, WA 982236111 USA

Invoice details

Invoice no.: 1375

Terms: Net 30

Invoice date: 04/08/2024

Due date: 05/08/2024

#	Date	Product or service	Description	Qty	Rate	Amount
1.		Josh Gentry	Labor Hours week ending March 23	8.15	\$59.07	\$481.42
2.		Josh Gentry	Operator hours week ending March 23	8.5	\$82.88	\$704.48
3.		Robert Gillette	Labor Hours week ending March 23	10.45	\$59.07	\$617.28
4.		Trent Kitchen	Labor Hours week ending March 23	8.5	\$59.07	\$502.10
5.		Trent Kitchen	Operator hours week ending March 23	16.65	\$82.88	\$1,379.95
6.		Dylan Landry	Labor Hours week ending March 23	20	\$59.07	\$1,181.40
7.		Charles Neighdy	Labor Hours week ending March 23	20	\$59.07	\$1,181.40
8.		Chris Oconnor	Operator hours week ending March 23	32	\$82.88	\$2,652.16
9.		John Oconnor	Labor Hours week ending March 23	32	\$59.07	\$1,890.24
10.		Kolton Palmer	Locator hours week ending March 23	25	\$82.25	\$2,056.25
11.		Josh Gentry	Labor Hours week ending March 30	32	\$59.07	\$1,890.24
12.		Trent Kitchen	Operator Hours week ending March 30	32	\$82.88	\$2,652.16
13.		Chris Oconnor	Operator Hours week ending March 30	32	\$82.88	\$2,652.16

14.	John Oconnor	Labor Hours week ending March 30	38	\$59.31	\$2,253.78
15.	Kolton Palmer	Locator Hours week ending March 30	16	\$82.25	\$1,316.00
16.	Josh Gentry	Operator Hours week ending April 6	24	\$82.88	\$1,989.12
17.	Robert Gillette	Labor Hours week ending April 6	16	\$59.07	\$945.12
18.	Trent Kitchen	Operator Hours week ending April 6	40	\$82.88	\$3,315.20
19.	Dylan Landry	Labor Hours week ending April 6	16	\$59.07	\$945.12
20.	Charles Neighdy	Labor Hours week ending April 6	14	\$59.07	\$826.98
21.	Chris Oconnor	Locator Hours week ending April 6	40	\$82.25	\$3,290.00
22.	John Oconnor	Labor Hours week ending April 6	40	\$59.31	\$2,372.40
23.	Kolton Palmer	Locator Hours week ending April 6	21	\$82.25	\$1,727.25
24.	Air Compressor		1	\$12,000.00	\$12,000.00
25.	Drill 100x120	Hour's drill spent in solid rock.	104	\$150.00	\$15,600.00
26.	Support Truck	Hour's drill spent in solid rock.	104	\$75.00	\$7,800.00
27.	Mud Truck	Hour's drill spent in solid rock.	104	\$75.00	\$7,800.00
28.	Vactor	Hour's drill spent in solid rock.	104	\$150.00	\$15,600.00
29.	Per day cost	(\$7509.40 per day plus 15%) = (\$8635.81x13days) = \$112,265.53	1	\$0.00	\$0.00
30.	Mark up	Plus 15%	1	\$14,643.32	\$14,643.32

Total **\$112,265.53**

Note to customer

Total hours worked on job. Roughly \$7,509.40 If you add 15% mark up and times it by the 13 days, we drilled through the rock it equals \$112,265.53.



8629 156th Street NE, Arlington, WA 98223
(425) 422-3825

Force Account

Project Number 2401	Project Name Pipeline Relocation SR20	Client / General Contractor Skagit PUD
Date of the Work 3/19 to 4/12	Item Number CO 01	Item Name Additional Field Supervision
Description of Work Performed Additional 3 weeks of field supervision for rock hammering from STA 39+15 to 37+80 and 1 week for supporting Sub to adhere to the original schedule timeline. This doesn't include the rock section that was encountered on 4/15/24.		

Time Worked Record								
Labor Name of Workers	Occupation	Hours Worked			Reg. Rate	O.T. Rate	D.T. Rate	Amount
		Reg.	OT	DT				
Travis Henderson	Foreman	70			\$ 70.67	\$ 106.01	\$ 141.34	\$ 4,946.90
Josh Frizzell	Superintendent	55			\$ 89.90	\$ 134.85	\$ 179.80	\$ 4,944.50
Labor Subtotal								\$ 9,891.40
Markup @ 20%								
Labor Total								\$ 9,891.40

Equipment Equipment # / Type/Size	Hours Worked		Reg. Rate	SB Rate	Amount
	Reg.	Standby			
03-05 2021 Ford F-350 Utility Truck	70		\$ 40.00	\$ 12.50	\$ 2,800.00
03-03 2020 Ford F-350	55		\$ 37.00	\$ 10.00	\$ 2,035.00
Equipment Subtotal					\$ 4,835.00
Markup @ 20%					
Equipment Total					\$ 4,835.00

Materials Description	Supplier	Invoice			Unit Price	Amount
			Quantity	Unit		
					\$ -	\$ -
					\$ -	\$ -
Materials Subtotal						\$ -
Markup @ 20%						\$ -
Materials Total						\$ -

Subcontractor Work Description of Work	Subcontractor	Invoice			Unit Price	Amount
			Quantity	Unit		
					\$ -	\$ -
					\$ -	\$ -
Subcontractor Subtotal						\$ -
Markup @ 5%						\$ -
Subcontractor Total						\$ -

SHEET TOTAL	\$ 14,726.40
--------------------	---------------------

Notes:			
Client's Representative	Date	EWS's Representative	Date



6100 238th Street SE Woodinville WA 98072
Phone: 866-695-5008
www.dpnicoli.com

INVOICE NO. : 404219
DATE: 3/23/2024
BILLING TYPE: CYCLE

Page: 1

Customer No. EART0001

BILL TO:

Earthwork Solutions
8629 156th St NE
Arlington WA 98223

SHIP TO:

Earthwork Solutions
59705 State Rte 20
Marblemount WA 98267

Scagit Paid.

CUST. JOB NO.:

JOBSITE CONTACT: Josh

OFFICE CONTACT:

PROJECT: Pipeline Relocation

SALESPERSON: Drew Woodruff

JOBSITE PHONE NO.: 360-540-1954

OFFICE PHONE NO.:

ORDER DATE: 3/7/2024

DPN ORDER #: 93761

TERMS: NET 30

Items Rented

Qty	Part Description	Date Out P.O. #	Contract # Del# /Ret#	Bill From Bill To	Min	Day	Week	4 Week	Total
2 EACH	Steel Plate 8 x 15 x 1	3/6/2024	157960 405476/ N/A	3/7/2024 4/3/2024	\$48.63	\$16.21	\$48.63	\$145.88	\$291.76
4 EACH	Steel Plate 8 x 10 x 1	3/6/2024	157960 405476/ N/A	3/7/2024 4/3/2024	\$40.74	\$13.58	\$40.74	\$122.23	\$488.92
1 EACH	12L x 8 Tall Build-A-Box Shield with 48in-72in Static Struts	3/6/2024	157960 405476/ N/A	3/7/2024 4/3/2024	\$349.47	\$116.49	\$349.47	\$1,048.42	\$1,048.42
1 EACH	8T x 12L x 3in Thick Aluminum XLAP Shield with 48in-72in Static Struts	3/6/2024	157960 405476/ N/A	3/7/2024 4/3/2024	\$349.47	\$116.49	\$349.47	\$1,048.42	\$1,048.42

Items Sold

Qty	Part Description	Date P.O. #	Contract # Del # / Ret #	Price	Ext Price
1 EACH	Delivery - DPN	3/6/2024	157960 405476 / N/A	\$198.00 EACH	\$198.00

Subtotal:	\$3,075.52
Environmental Fee:	\$43.16
WA State Heavy Rental Equipment Tax:	\$39.00
Tax:	\$268.23
Total Invoice:	\$3,425.91

No additional equipment/service outstanding for this rental order.

Please remit to: D.P. NICOLI, INC. PO BOX 31001-3165 PASADENA CA 91110-3165

ESTIMATE

Sound Drilling LLC

24499 east state street

Sedro Woolley, WA 98284

kolton@sounddrillingllc.com

+1 (425) 244-2303

www.sounddrillingllc.com

Josh Frizzell

Bill to

Josh Frizzell

Earthwork Solutions, LLC

8629 156TH ST NE

ARLINGTON, WA 982236111 USA

Ship to

Josh Frizzell

Earthwork Solutions, LLC

8629 156TH ST NE

ARLINGTON, WA 982236111 USA

Estimate details

Estimate no.: 1270

Estimate date: 04/08/2024

#	Date	Product or service	Description	Qty	Rate	Amount
1.		Rock reaming	200 feet of rock reaming to a 24 inch hole	1	\$15,000.00	\$15,000.00
2.		Over reaming	ream to a 30 inch hole	1	\$32,000.00	\$32,000.00
					Total	\$47,000.00

2024 Judy Reservoir Inflows & Elevation

May 15 Elevation:	458.07 (ft)
May 22 Elevation:	460.49 (ft)
Change in Elevation:	2.42 (+ 29.0 Inches)
Spillway Elevation:	465.10
Stream Inflow YTD:	642.54 MG
Skagit River YTD:	767.43 MG

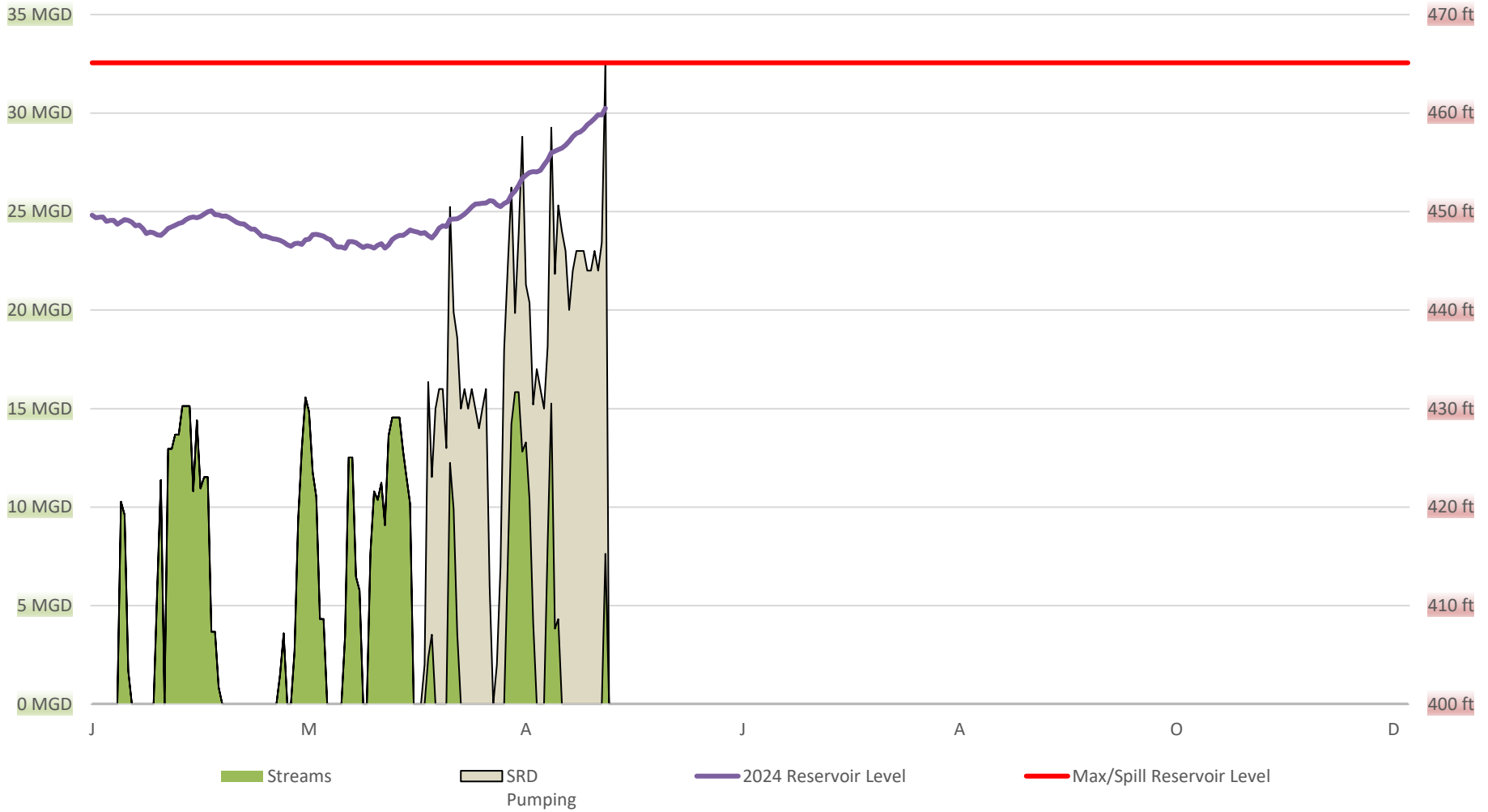

5-YEAR JUDY RESERVOIR ELEVATIONS

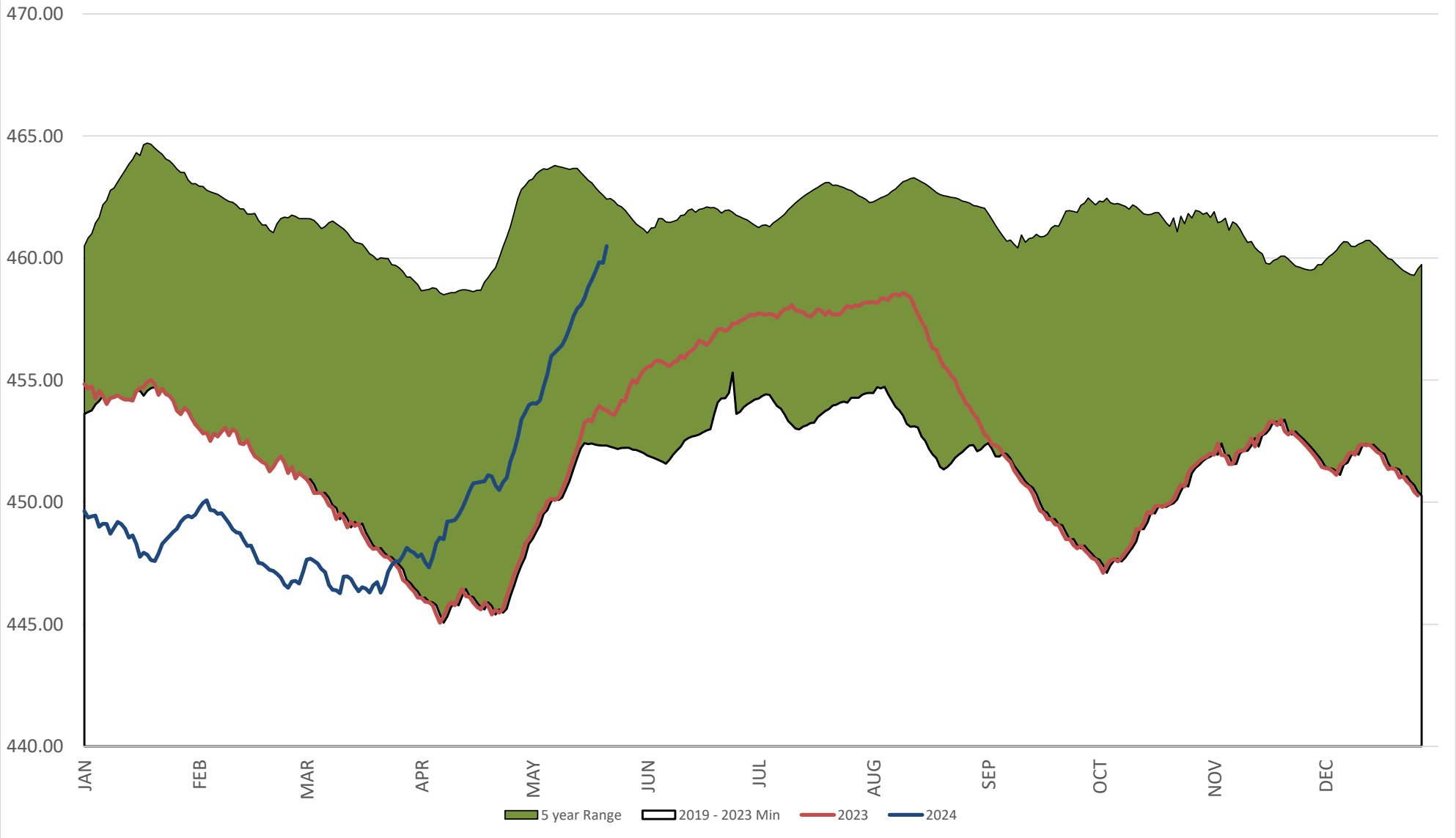

https://www.goskagit.com/news/environment/skagit-pud-holds-annual-tours-of-judy-reservoir/article_6e728988-0e86-11ef-a288-bb5f5a25dcf6.html

Skagit PUD holds annual tours of Judy Reservoir

EMMA FLETCHER-FRAZER Skagit Valley Herald
May 11, 2024

1 of 2



Judy Reservoir is pictured Thursday east of Clear Lake. When full, the lake is 60 feet deep and holds 1.5 billion gallons of water. Photo by Oliver Hamlin / Skagit Valley Herald

JUDY RESERVOIR — The Skagit Public Utility District offered its annual community tours of Judy Reservoir this week, as part of Drinking Water Week.

District staff led tours of the water treatment plant and the reservoir, chatting about the history of the water utility and water usage.

Skagit County voters approved creation of the Skagit Public Utility District in 1936, Community Relations Manager Kevin Tate said.

"We were off and running," said Tate.

The district serves about 85,000 residents, including those the cities of Mount Vernon, Sedro-Woolley and Burlington.

Its water is mainly stored in Judy Reservoir, which is a manmade lake that is contained by two rock and earthen dams.

When full, the lake is 60 feet deep and holds 1.5 billion gallons of water.

It was named after the utility's first general manager.

Water in the reservoir comes from streams in the Cultus Mountain watershed, and from the Skagit River.

The PUD has grown to rely more heavily on water from the Skagit River in recent years, said Treatment Plant Foreman Gary Tollefson.

Drier conditions have caused creeks in the Cultus Mountain watershed to have less water.

In 2010, 41% of the utility's water came from the Skagit River. Last year, it was 77%.

Visitors from throughout the county viewed the treatment plant and reservoir on Thursday.

Taylor Scott, a Mount Vernon resident and Skagit Conservation District staff member, took the tour to learn more about the local water system.

Scott said she hadn't realized so much of the local water was drawn from the Skagit River, and was glad to have learned more about the process.

Inside the water treatment plant, staff showed visitors the process to treat the unfiltered water.

One step is a process called flocculation, which bonds particles together to more easily filter them out.

The utility also uses chlorine gas to disinfect the water.

Due to rising costs and stiff regulations on chlorine gas, the utility is considering moving instead toward bleach.

Staff at the water treatment plant use a programmable controller to check water pressure and keep an eye on the treatment process.

Staff also measure pH and other factors in the water every two hours.

Emma Fletcher-Frazer can be reached at efletcher-frazer@skagitpublishing.com, 360-416-2199, Twitter: @Emma_SVH

Emma Fletcher-Frazer