

**TECHNICAL SPECIFICATIONS**



**NORTH BURLINGTON PIPELINE REPLACEMENT  
PROJECT**

**CP # 4804-3498**

**ISSUED FOR BIDDING**

**August 9, 2024**

**DISTRICT OFFICE**

1415 Freeway Drive  
Mount Vernon, WA 98273  
(360) 424-7104 -- Telephone  
(360) 424-8764 -- Facsimile

**DISTRICT OFFICIALS**

Commission

Joe Lindquist, President  
Andrew Miller, Vice-President  
Corrin Hamburg, Secretary

General Manager

George Sidhu, P.E.

Engineering Manager

Mark C. Handzlik, P.E.

Operations Manager

Mike Fox



# Specifications and Bid Documents

## North Burlington Pipeline Replacement Project

---

### CERTIFICATION

---

These specifications and design drawings for the **North Burlington Pipeline Replacement Project** have been prepared under the direction of the following Registered Professional Engineer.

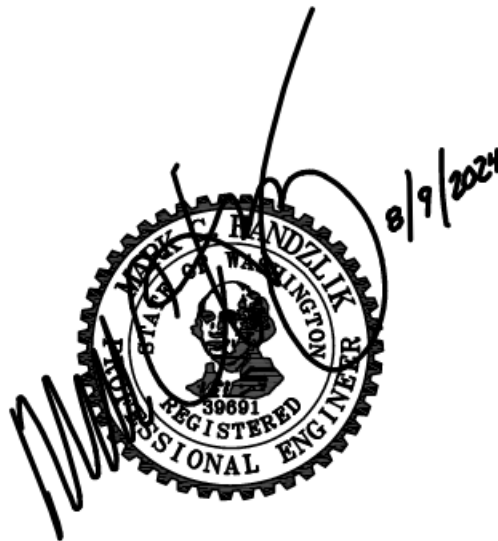

# TABLE OF CONTENTS

## INVITATION TO BID

### INSTRUCTIONS TO BIDDERS

General	Instructions - 1
Location	Instructions - 1
Examination of Plans, Specifications, and Site	Instructions - 1
Bid Documents	Instructions - 2
Bids	Instructions - 2
Bid Deposit	Instructions - 2
Evaluation of Bids and Award of Contract	Instructions - 2
Responsibility Criteria	Instructions - 3
Mandatory Responsibility Criteria	Instructions - 3
Subcontractor Responsibility Criteria	Instructions - 4
Protests	Instructions - 4
Contract Time	Instructions - 4
Failure to Execute Contract and Furnish Bond	Instructions - 4
Corrections, Interpretations, and Addenda	Instructions - 4
Sub-Contractors and Suppliers	Instructions - 5
Bidder Qualifications	Instructions - 5
Permits	Instructions - 5
Pre-Bid Meeting	Instructions - 5
Mandatory Bidder Responsibility Checklist	Instructions - 6
Subcontractor Responsibility Checklist	Instructions - 7

### BID PROPOSAL FORMS

Bidder's Checklist	Proposal - 1
Bid to Commission	Proposal - 2
Bid Proposal Schedule	Proposal - 3
Bid Proposal Signature Sheet	Proposal - 6
Subcontractor and Supplier Listing—RCW 39.30.060	Proposal - 7
Statement of Bidder's Qualifications	Proposal - 9
Bid Bond	Proposal - 10
Certification of Compliance with Wage Payment Statutes	Proposal - 11

### AGREEMENT

Contract	Agreement - 1
Indemnification Agreement	Agreement - 3
Certificate of Owner's Attorney	Agreement - 4
Performance and Payment Bond	Agreement - 5
Certificate as to Corporate Seal	Agreement - 7

### GENERAL AND SUPPLEMENTARY GENERAL CONDITIONS

General Conditions	GC - 1
Supplementary General Conditions	SGC - 1
1 Order of Precedence	SGC - 1
2 Section 1-01.3 Definitions (APWA)	SGC - 2
3 Section 1-03 Award and Execution of Contract	SGC - 2

3.1	Section 1-03.4	Contract Bond	SGC – 2
3.2	Section 1-03.8	Award and Execution of Contract	SGC – 2
4	Section 1-05	Control of Work	SGC – 3
4.1	Section 1-05.0	Control of Work – General	SGC – 3
4.2	Section 1-05.4	Conformance with and Deviations from Plans and Stakes	SGC – 3
4.3	Section 1-05.10	Guarantees	SGC – 3
5	Section 1-07	Legal Relations and Responsibilities	SGC – 4
5.1	Section 1-07.1	Owner Safe Access	SGC – 4
5.2	Section 1-07.6	Permits and Licenses	SGC – 4
5.3	Section 1-07.9	Wages	SGC – 4
5.4	Section 1-07.18	Public Liability and Property Damage Insurance	SGC – 4
5.5	Section 1-07.26	Personal Liability of Public Officers	SGC – 4
6	Section 1-08	Prosecution and Progress	SGC – 5
6.1	Section 1-08.5	Time for Completion (Contract Time) (APWA)	SGC – 5
6.2	Section 1.08.9	Liquidated Damages	SGC – 5
6.3	Section 1.08.10(2)	Termination for Public Convenience	SGC – 5
7	Section 1-09	Measurement and Payment	SGC – 5
7.1	Section 1-09.4	Equitable Adjustment	SGC – 5
7.2	Section 1-09.6	Force Account	SGC – 5
7.3	Section 1-09.11(3)	Time Limitations and Jurisdiction	SGC – 5
7.4	Section 1-09.13(3)	Claims Resolution	SGC – 6
7.5	Section 1-09.14	Claims Against Contractor’s Retainage and/or Public Contract Bond	SGC – 6
8	Section	Temporary Traffic Control	SGC – 6
8.1	Section 1-10.2(2)	Traffic Control Plans	SGC – 6

## TECHNICAL SPECIFICATIONS

### Division 1 - General Requirements

- 01010 Summary of Work
- 01025 Measurement and Payment
- 01060 Regulatory Requirements
- 01070 Abbreviations of Institutions
- 01090 Reference Standards
- 01300 Contractor Submittals
- 01311 Scheduling and Reporting
- 01313 Construction and Schedule Constraints
- 01350 Safe Workplace
- 01400 Quality Control
- 01505 Mobilization
- 01550 Site Access and Storage
- 01560 Environmental Controls
- 01570 Traffic Control
- 01600 Products, Materials, Equipment and Substitutions
- 01700 Project Closeout

### Division 2 - Site Work

- 02100 Site Preparation
- 02140 Dewatering
- 02270 Erosion and Sediment Control
- 02300 Trenching, Backfilling, and Compacting for Utilities
- 02567 Interfering Utility Protection
- 02700 Bases, Ballasts, Pavement and Appurtenance

Division 3 - Concrete

03002 Concrete

Division 5 - Metals

05500 Miscellaneous Metalwork and Castings

Division 15 - Mechanical

15001 Piping: General

15062 Piping: Ductile Iron

15080 Pipe: Plastic Crosslinked Polyethylene (Rehau Municipex Pipe)

15100 Valves: Basic Requirements

15101 Gate Valves

15110 Ductile – Iron Fittings and Hydrants

15120 Miscellaneous Valves

15950 Water Pipeline Testing and Disinfection

## **APPENDICES**

Appendix A Prevailing Wage

Appendix B Permits

Appendix C Inadvertent Discovery Plan

# **INVITATION TO BID**

## INVITATION TO BID

Notice is hereby given that Public Utility District No. 1 of Skagit County (Skagit PUD) will receive sealed Bids for the **North Burlington Pipeline Replacement Project**. Each bid shall be placed in a sealed envelope and shall be mailed or delivered to Skagit PUD's office, Attn: Chris Shaff, P.E., Capital Project Engineer, 1415 Freeway Drive, Mount Vernon, Washington 98273, to arrive no later than 10:00 AM, Friday, August 23, 2024. All complete bids will be opened and publicly read immediately following.

### **North Burlington Pipeline Replacement Project**

Installation of approximately 7,550 linear feet of water distribution piping along Hazel Avenue, North Walnut Street, Avon Avenue, Magnolia Avenue, North Oak Street, North Cherry Street, North Pine Street, North Anacortes Street, South Walnut Street, and South Alder Street in the City of Burlington, State of Washington, consisting of 8-inch, diameter Ductile Iron piping including fittings, thrust blocks, service connections, fire hydrants, branch and mainline valves, establishment of private water service connections, dewatering, appurtenances and incidentals, pavement repair, abandonment of existing valves in place, temporary traffic control, temporary erosion control, disinfection, and pressure testing, in estimated quantities identified in the Bid Proposal and as shown on the plans.

The location of the proposed work is shown on the project plans.

A Pre-Bid Meeting will be held at 10:00 AM on Monday August 19, 2024, in the Aqua Room of Skagit PUD's Mount Vernon office complex at 1415 Freeway Drive, Mount Vernon, Washington.

An unofficial bid set can be viewed at Skagit PUD's office located at 1415 Freeway Drive, Mount Vernon, Washington 98273, or on PUD's website [www.SkagitPUD.org](http://www.SkagitPUD.org). Construction plans, specifications, addenda, and plan holders list for this project can be viewed or purchased on-line through Builders Exchange of Washington, Inc., at <http://www/bxwa.com>; 2607 Wetmore Avenue, Everett, WA 98201-2929, (425) 258-1303, Fax (425) 259-3832. Click on: "bxwa.com"; "Posted Projects"; "Public Works", "PUD #1 of Skagit County" and "Projects Bidding". (*Note: Bidders are encouraged to "Register as a Bidder" in order to receive automatic e-mail notification of future addenda and to be placed on the "Bidders List". This service is provided free of charge to Prime Bidders, Subcontractors and Vendors bidding this project. Contact Builders Exchange of Washington at (425) 258-1303, should you require further assistance.*) Contract documents will be available on or after August 9, 2024.

Point of Contact: Chris Shaff, P.E., Capital Project Engineer

PUBLIC UTILITY DISTRICT NO. 1 OF SKAGIT COUNTY

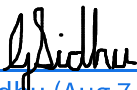
  
\_\_\_\_\_  
George Sidhu (Aug 7, 2024 12:20 PDT)

George Sidhu, P.E., General Manager

Published: August 9 & August 16, 2024 (Skagit Valley Herald)  
August 9, 2024 (Daily Journal of Commerce)



# **INSTRUCTIONS TO BIDDERS**

## INSTRUCTIONS TO BIDDERS

### 1.01 GENERAL

The **North Burlington Pipeline Replacement Project** consists of the following:

Installation of approximately 7,550 linear feet of water distribution piping along Hazel Avenue, North Walnut Street, Avon Avenue, Magnolia Avenue, North Oak Street, North Cherry Street, North Pine Street, North Anacortes Street, South Walnut Street, and South Alder Street in the City of Burlington, State of Washington, consisting of 8-inch, diameter Ductile Iron piping including fittings, thrust blocks, service connections, fire hydrants, branch and mainline valves, establishment of private water service connections, dewatering, appurtenances and incidentals, pavement repair, abandonment of existing valves in place, temporary traffic control, temporary erosion control, disinfection, and pressure testing, in estimated quantities identified in the Bid Proposal and as shown on the plans.

An unofficial bid set can be viewed at Skagit PUD's office located at 1415 Freeway Drive, Mount Vernon, Washington 98273, or on PUD's website [www.SkagitPUD.org](http://www.SkagitPUD.org). Construction plans, specifications, addenda, and plan holders list for this project can be viewed or purchased on-line through Builders Exchange of Washington, Inc., at <http://www/bxwa.com>; 2607 Wetmore Avenue, Everett, WA 98201-2929, (425) 258-1303, Fax (425) 259-3832. Click on: "bxwa.com"; "Posted Projects"; "Public Works", "PUD #1 of Skagit County" and "Projects Bidding". (*Note: Bidders are encouraged to "Register as a Bidder" in order to receive automatic e-mail notification of future addenda and to be placed on the "Bidders List". This service is provided **free of charge** to Prime Bidders, Subcontractors and Vendors bidding this project. Contact Builders Exchange of Washington at (425) 258-1303, should you require further assistance.*) Addenda will be sent out to those who "Register as a Bidder" on Builders Exchange of Washington, Inc., at <http://www/bxwa.com>. Contract documents will be available on or after August 9, 2024.

### 2.01 LOCATION

The location for the project is North Burlington on Hazel Avenue, North Walnut Street, Avon Avenue, Magnolia Avenue, North Oak Street, North Cherry Street, North Pine Street, North Anacortes Street, South Walnut Street, and South Alder Street within the City of Burlington, State of Washington as shown on the Contract Drawings.

### 3.01 EXAMINATION OF PLANS, SPECIFICATIONS, AND SITE

Bidders shall satisfy themselves as to construction conditions by personal examination of the Plans, Specifications, other Bid Documents, and from attendance at applicable Pre-Bid Meetings. Bidders shall carefully correlate their observations with the requirements of the Contract Documents, and shall otherwise satisfy themselves regarding the expense and difficulties associated with performing the Work, and shall fully account for it in their bids. The submission of a bid shall constitute a representation of compliance by the Bidder with this requirement.

### 3.03 BID DOCUMENTS

The Bid Documents for the Project include the following:

Project Manual including general and technical specifications.  
Contract Drawings.

### 4.01 BIDS

The project will be awarded based on the lowest responsive responsible Bidder.

Bids shall be made on the forms included herewith and shall be addressed to the Public Utility District No. 1 of Skagit County, 1415 Freeway Drive, Mount Vernon, Washington 98273. Each Bid shall be placed in a sealed envelope and shall be mailed or delivered to the Public Utility District No. 1 of Skagit County, to arrive no later than 10:00 AM on Friday August 23, 2024. All complete Bids will be opened and publicly read aloud immediately following. No Bid may be withdrawn after the time set for the Bid opening or before award and execution of the contract unless the Owner does not award the contract within sixty (60) calendar days after the opening of Bids.

### 5.01 BID DEPOSIT

As a guarantee of good faith and as required by law, each Bid shall be accompanied by a Bid Deposit in the form of certified check, cashier's check, postal money order, or surety bond payable to the order of the "Public Utility District No. 1 of Skagit County" for an amount not less than 5 percent of the total amount of the Bid, including all potential additions and alternatives, but not including sales tax. If a surety bond is to be used as the bid deposit, the document included with the bid submission must have original signatures. The Bid Deposits of the three lowest Bidders will be retained until the Contract between the successful Bidder and the Owner have been entered into and a Performance and Payment Bond in an amount of one-hundred percent (100%) of the contract price has been filed as required under these Contract Documents. The Bid Deposits of each other Bidder will be returned as soon as it is determined that they are not one of the three lowest Bidders.

### 6.01 EVALUATION OF BIDS AND AWARD OF CONTRACT

The Owner will award the Bid to the lowest responsive, responsible Bidder based on the Total Bid Amount as stated on the Bid Proposal Form. In the case of a conflict between the Total Bid Amount as stated numerically and as stated in words, the words shall take precedence.

In the case of a conflict between the quantity, unit price and unit price extension for a given bid item, the Owner will make adjustments to the unit price extensions based on the unit price. If the Bidder does not provide a unit price or a unit price extension for every bid item, the bid will be considered non-responsive.

The right is reserved by the Owner to waive any and all informality in the Bids, to reject any or all Bids, including nonresponsive, unbalanced, or conditional bids, to reject any or all schedules, to re-advertise for new Bids, or to otherwise carry out the Work. The Owner reserves the right to

reject any bid that is materially unbalanced to the Owner's potential detriment. The Owner further reserves the right to delete portions of the Work.

Bids which are incomplete, or which are conditioned in any way, or which contain erasures, alterations, or items not called for in the Bid Form, or which are not in conformity with the law or these Instructions, may be rejected as non-responsive

## 6.02 RESPONSIBILITY CRITERIA

Before the Owner awards the contract, state law is used to determine that responsible contractors and subcontractors perform the work. Bidder responsibility is determined by the Bidder successfully demonstrating its ability to satisfy the mandatory responsibility criteria and any project specific criteria established by the Owner.

To comply with the responsibility criteria for this bid, a Bidder must provide sufficient information as required. If the Bidder fails to provide the requested information within the time and manner specified in these bid documents, the Owner reserves the option to determine responsibility upon any available information related to any supplemental criteria and/or may find the Bidder not responsible. If the lowest Bidder is found not responsible, the Owner reserves the right to award to the next low Bidder without re-advertising or rebidding the project.

## 6.03 MANDATORY RESPONSIBILITY CRITERIA

It is the intent of Owner to award a contract to the low responsible bidder. Before award, the bidder must meet the following Bidder responsibility criteria to be considered a responsible bidder. The Bidder may be required by the Owner to submit documentation demonstrating compliance with the criteria. The Bidder must:

1. Have a current certificate of registration as a contractor in compliance with chapter 18.27 RCW, which must have been in effect at the time of bid submittal;
2. Have a current Washington Unified Business Identifier (UBI) number;
3. If applicable:
  - a) Have Industrial Insurance (workers' compensation) coverage for the bidder's employees working in Washington, as required in Title 51 RCW;
  - b) Have a Washington Employment Security Department number, as required in Title 50 RCW;
  - c) Have a Washington Department of Revenue state excise tax registration number, as required in Title 82 RCW;
4. Not be disqualified from bidding on any public works contract under RCW 39.06.010 or 39.12.065(3).
5. Until December 31, 2013, not have violated more than one time the off-site, prefabricated, non-standard, project specific items reporting requirements of RCW 39.04.370.
6. For public works projects subject to the apprenticeship utilization requirements of RCW 3.0.04.320, not have been found out of compliance by the Washington state apprenticeship and training council for working apprentices out of ratio, without

appropriate supervision, or outside their approved work processes as outlined in their standards of apprenticeship under chapter 49.04 RCW for the one-year period immediately preceding the first date of advertising for the project.

7. Prior to the award date, the Contractor shall produce evidence of having received by the Department of Labor & Industries training on prevailing wage and public works requirements or are exempt under RCW 39.04.350

#### 6.04 SUBCONTRACTOR RESPONSIBILITY CRITERIA

Before award, the Bidder shall verify responsibility criteria for each first tier subcontractor the Contractor hires and a subcontractor of any tier subcontractor that hires other subcontractors must verify responsibility criteria for each of its subcontractors. Verification shall occur at the time of subcontract execution and shall include that each subcontractor meets the responsibility criteria listed in Section 6.03 and possesses an electrical contractor license (if required by RCW Chapter 19.28) or an elevator contractor license (if required by RCW Chapter 70.87). These verification requirements, as well as the responsibility criteria, shall be included in each of the Contractor's subcontracts of any tier. The Contractor shall certify that this verification is complete prior to contract close-out.

#### 6.05 PROTESTS

Any Bidders wanting to file a bid protest shall submit a formal protest consisting of an email submitted to Shaff@skagitpud.org that is written and sent from an authorized corporate official within 72 hours of the bid opening. The protest will be reviewed by the Owner and if warranted, a meeting will be held with the Owner, the low Bidder and the Bidder filing the protest within 4 Calendar days to review the protest. A decision on the protest will be made by the Owner within 7 Calendar days.

#### 6.06 CONTRACT TIME

The Contract completion date is an essential part of the Contract, and it will be necessary for each Bidder to satisfy the Owner of its ability to complete the Work within the time allowed. Bidders shall base their bids on utilizing a finish date of November 15, 2024 for the Work, as specified.

#### 7.01 FAILURE TO EXECUTE CONTRACT AND FURNISH BOND

In the event the successful Bidder fails to furnish a Payment and Performance Bond complying with this Invitation for Bids, and fails to sign the contract within ten (10) calendar days after notification by the Owner, an amount equal to 5 percent of the amount of the Bid shall be forfeited to the Owner as liquidated damages, and it is agreed that this said sum is a fair estimate of the amount of damages the Owner would sustain in the event that the Bidder failed to enter into the Contract or furnish the required Bond. Said liquidated damages shall be paid from the Bid Deposit submitted with the Bid. Other Bids will then be reconsidered for award by the Owner.

## 8.01 CORRECTIONS, INTERPRETATIONS, AND ADDENDA

If Bidders find or observe any omissions, discrepancies, or need for interpretations of the Bid Documents, they shall bring such facts in writing to the attention of the Owner. Written addenda to clarify questions which arise will then be issued. Interpretations or explanations of the Contract Documents will be in the form of written addenda only. Oral statements by the Owner, Engineer, or other representative of the Owner whether made before or after award of the Contract shall in no way modify the Contract Documents.

Any requests for information or interpretation of the Bid Documents shall be made by phone or email to Chris Shaff, P.E., Capital Project Engineer (360)391-9282 or Shaff@SkagitPUD.org. All such requests shall be received no later than three (3) days prior to Bid opening.

## 10.01 SUBCONTRACTORS & SUPPLIERS

In compliance with RCW 39.30.060 for all projects estimated to cost \$1 million or more, all Bidders must complete and submit the Subcontractors List form provided in the Bid Proposal Forms. The Subcontractors List form must be submitted with the Bid. The failure of a Bidder to submit the names of such subcontractors, or to name itself to perform such work, or the naming of two or more firms (subcontractors or Bidders) to perform the same work shall render the Bidder's bid non-responsive and, therefore, void.

## 11.01 BIDDER QUALIFICATIONS

All Bidders shall submit with their bids evidence of sufficient qualifications and experience for the work as specified in Bid Proposal Forms. The Owner will utilize the information submitted for the purpose of determining the responsibility of the low Bidder for determining eligibility for award.

## 12.01 PERMITS

The Owner has obtained or will obtain the permits and approvals required for the Work as listed below. The Contractor shall comply with the provisions of all permits, approvals and easements. All other required permits or licenses (i.e. right of way permits) shall be the responsibility of the Contractor. Owner-obtained permit and approvals, which is included for reference in Appendix B is: City of Burlington Right of Way Permit.

Should the Contractor procure additional formal or informal access easements, rights of entry, Work or storage areas, or enter private property, he/she shall obtain and file all such private property agreements with the Owner prior to such access. The Contractor shall provide to the Owner property release forms for all Work or access on private property.

## 13.01 PRE-BID MEETING

A Pre-Bid Meeting will be held at 10:00 AM on Monday, August 19, 2024, in the Aqua Room of Skagit PUD's Mount Vernon office complex.

END OF SECTION

# Mandatory Bidder Responsibility Checklist

The following checklist may be used by Owners in documenting that a Bidder meets the mandatory bidder responsibility criteria. It is suggested that Owners print a copy of documentation from the appropriate website to include with this checklist in the contract file.

<b>General Information</b>	
Project Name:	Project Number:
Bidder's Business Name:	Bid Submittal Deadline:
<b>Contractor Registration –</b> <a href="https://fortress.wa.gov/lni/bbip/">https://fortress.wa.gov/lni/bbip/</a>	
License Number:	Status: Active: Yes <input type="checkbox"/> No <input type="checkbox"/>
Effective Date (must be effective on or before Bid Submittal Deadline):	Expiration Date:
Is Bidder on Infraction List?	Yes <input type="checkbox"/> No <input type="checkbox"/>
<b>Current UBI Number –</b> <a href="http://dor.wa.gov/content/doingbusiness/registermybusiness/brd/">http://dor.wa.gov/content/doingbusiness/registermybusiness/brd/</a>	
UBI Number:	Account Closed: Open <input type="checkbox"/> Closed <input type="checkbox"/>
<b>Industrial Insurance Coverage –</b> <a href="https://fortress.wa.gov/lni/crpsi/MainMenu.aspx">https://fortress.wa.gov/lni/crpsi/MainMenu.aspx</a>	
Account Number:	Account Current: Yes <input type="checkbox"/> No <input type="checkbox"/>
<b>Employment Security Department Number –</b>	
Employment Security Department Number:	
• Has Bidder provided account number on the Bid Form?	Yes <input type="checkbox"/> No <input type="checkbox"/>
• And/or have you asked the Bidder for documentation from Employment Security Department on account number?	Yes <input type="checkbox"/> No <input type="checkbox"/>
<b>State Excise Tax Registration Number –</b> <a href="http://dor.wa.gov/content/doingbusiness/registermybusiness/brd/">http://dor.wa.gov/content/doingbusiness/registermybusiness/brd/</a>	
Tax Registration Number:	Account Closed: Open <input type="checkbox"/> Closed <input type="checkbox"/>
<b>Not Disqualified from Bidding –</b> <a href="http://www.lni.wa.gov/TradesLicensing/PrevWage/AwardingAgencies/DebarredContractors/default.asp">http://www.lni.wa.gov/TradesLicensing/PrevWage/AwardingAgencies/DebarredContractors/default.asp</a>	
Is the Bidder listed on the "Contractors Not Allowed to Bid" list of the Department of Labor and Industries?	
Yes <input type="checkbox"/> No <input type="checkbox"/>	
<b>Checked by:</b>	
Name of Employee:	Date:

## Subcontractor Responsibility Checklist

The following checklist may be used by Contractors and Subcontractors in documenting that a subcontractor of any tier meets the subcontractor responsibility criteria. It is suggested that Contractors and Subcontractors print a copy of documentation from the appropriate website to include with this checklist in their contract file.

<b>General Information</b>	
Project Name:	Project Number:
Subcontractor's Business Name:	Subcontract Execution Date:
<b>Contractor Registration –</b> <a href="https://fortress.wa.gov/lni/bbip/">https://fortress.wa.gov/lni/bbip/</a>	
License Number:	Status: Active: Yes <input type="checkbox"/> No <input type="checkbox"/>
Effective Date (must be effective on or before Subcontract Bid Submittal Deadline):	Expiration Date:
<b>Current UBI Number –</b> <a href="http://dor.wa.gov/content/doingbusiness/registermybusiness/brd/">http://dor.wa.gov/content/doingbusiness/registermybusiness/brd/</a>	
UBI Number:	Account Closed: Open <input type="checkbox"/> Closed <input type="checkbox"/>
<b>Industrial Insurance Coverage –</b> <a href="https://fortress.wa.gov/lni/crpsi/MainMenu.aspx">https://fortress.wa.gov/lni/crpsi/MainMenu.aspx</a>	
Account Number:	Account Current: Yes <input type="checkbox"/> No <input type="checkbox"/>
<b>Employment Security Department Number –</b>	
Employment Security Department Number:	
<ul style="list-style-type: none"> <li>• Has Subcontractor provided account number on the Bid Form? Yes <input type="checkbox"/> No <input type="checkbox"/></li> <li>• And/or have you asked the Subcontractor for documentation from Employment Security Department on account number? Yes <input type="checkbox"/> No <input type="checkbox"/></li> </ul>	
<b>State Excise Tax Registration Number –</b> <a href="http://dor.wa.gov/content/doingbusiness/registermybusiness/brd/">http://dor.wa.gov/content/doingbusiness/registermybusiness/brd/</a>	
Tax Registration Number:	Account Closed: Open <input type="checkbox"/> Closed <input type="checkbox"/>
<b>Not Disqualified from Bidding –</b> <a href="http://www.lni.wa.gov/TradesLicensing/PrevWage/AwardingAgencies/DebarredContractors/default.asp">http://www.lni.wa.gov/TradesLicensing/PrevWage/AwardingAgencies/DebarredContractors/default.asp</a>	
Is the Subcontractor listed on the "Contractors Not Allowed to Bid" list of the Department of Labor and Industries? Yes <input type="checkbox"/> No <input type="checkbox"/>	
<b>Contractor Licenses –</b> <a href="https://fortress.wa.gov/lni/bbip/">https://fortress.wa.gov/lni/bbip/</a>	
<u>Electrical:</u> If required by Chapter 19.28 RCW, does the Subcontractor have an Electrical Contractor's License? Yes <input type="checkbox"/> No <input type="checkbox"/>	<u>Elevator:</u> If required by Chapter 70.87 RCW, does the Subcontractor have an Elevator Contractor's License? Yes <input type="checkbox"/> No <input type="checkbox"/>
<b>Checked by:</b>	
Name of Employee:	Date:



# **BID PROPOSAL FORMS**

**BID PROPOSAL FORM**

**BIDDER'S CHECKLIST**

This Checklist has been prepared and furnished to aid Bidders in including all necessary supporting information with their Bid. Bidder's submittals shall include, but not be limited to, the following:

ITEM	CHECKED
1. Bid to Commission	_____
2. Bid Schedule	_____
3. Proposal Signature, Addenda Acknowledgement and Non-Collusion Declaration Sheet	_____
4. Subcontractor List	_____
5. Statement of Bidder's Qualifications	_____
6. Bid Deposit	_____

## **BID TO COMMISSION**

TO: Board of Commissioners  
Public Utility District No. 1 of Skagit County, Washington

Gentlemen:

The undersigned has examined the site, specifications, plans, laws and ordinances covering the improvements contemplated. In accordance with the terms, provisions and requirements of the foregoing, the following lump sums and unit prices are tendered as an offer to perform the Work and furnish the labor, tools, equipment, materials, appurtenances, incidentals, and guarantees, where required, complete in place, in good working order.

As a guarantee of good faith and as required by law, a Bid Deposit in the form of a certified check, cashier's check, postal money order or surety bond made payable to the order of Public Utility District No. 1 of Skagit County ("Skagit PUD") is attached hereto. The undersigned understands and hereby agrees that, should this offer be accepted and the undersigned fail or refuse to enter into a Contract, furnish the required Payment and Performance Bond and required liability insurance, the undersigned shall forfeit to Skagit PUD an amount equal to five percent (5%) of the amount Bid as liquidated damages, all as provided for in this Invitation for Bids.

The undersigned hereby proposes to undertake and complete the work embraced in this improvement, in accordance with the terms of the Specifications and Contract Documents, at the following lump sum and unit prices:

# **NORTH BURLINGTON PIPELINE REPLACEMENT PROJECT**

## **BID SCHEDULE**

<b>Item No.</b>	<b>Bid Schedule Description</b>	<b>Estimated Quantity</b>	<b>Unit</b>	<b>Unit Price</b>	<b>Total</b>
1	Mobilization	1	LS	\$	\$
2	Accident Prevention Program and Site Specific Health and Safety Plan, Including COVID-19 Protection Plan	1	LS	\$	\$
3	SPCC and TESC Plan	1	LS	\$	\$
4	ESC Lead	1	LS	\$	\$
5	Install and Maintain Temporary Erosion Control and Water Pollution Control Measures	1	LS	\$	\$
6	Traffic Control Supervisor	50	DAY	\$	\$
7	Flaggers	1,100	HR	\$	\$
8	Traffic Control Signs and Devices	1	LS	\$	\$
9	Furnish Portable Changeable Message Signs (PCMS)	10	DAY	\$	\$
10	Furnish and Install Adequate Site and Trench Safety Systems in Accordance with Chapter RCW 49.17	7,550	LF	\$	\$
11	Sawcut Pavement for Permanent Patch	8,940	LF	\$	\$
12	Furnish and Install Engineer-Ordered Trench Stabilization Material	20	TON	\$	\$
13	Furnish and Install Engineer-Ordered Over Excavation	20	CY	\$	\$
14	Furnish and Place Crushed Surfacing Material, Top Course	1,050	TON	\$	\$
15	Furnish, Place and Compact HMA Class ½-Inch, P.G. 64-22 for Permanent Patch	725	TON	\$	\$
16	Furnish & Install 8" Ductile Iron Pipe, CL 50 Including Trench Excavation, Backfill and Compaction	6,989	LF	\$	\$
17	Furnish and Install 8" x 8" DI Cross, Fitting	5	EA	\$	\$
18	Furnish and Install 8" x 8" DI Tee, Fitting	7	EA	\$	\$
19	Furnish and Install 8" x 6" DI Tee, Fitting	2	EA	\$	\$
20	Furnish and Install 8" x 4" DI Tee, Fitting	1	EA	\$	\$
21	Furnish and Install 8" DI 90 Degree Bend, Fitting	1	EA	\$	\$
22	Furnish and Install 8" DI 45 Degree Bend, Fitting	17	EA	\$	\$
23	Furnish and Install 8" DI 11.25 Degree Bend, Fitting	2	EA	\$	\$

<b>Item No.</b>	<b>Bid Schedule Description</b>		<b>Unit</b>	<b>Unit Price</b>	<b>Total</b>
24	Furnish and Install 8" x 6" DI Reducer, Fitting	1	EA	\$	\$
25	Furnish and Install 8" DI Flange Adapter, Fitting	22	EA	\$	\$
26	Furnish and Install 8" DI Gate Valve w/ Valve Box and Cover	40	EA	\$	\$
27	Furnish and Install 8" x 2" Blind Flange Assembly w/ 2" DI Gate Valve at STA 70+20 (Magnolia Ave)	1	LS	\$	\$
28	Furnish & Install 6" Ductile Iron Pipe, CL 50 Including Trench Excavation, Backfill and Compaction	200	LF	\$	\$
29	Furnish and Install 6" DI 45 Degree Bend, Fitting	3	EA	\$	\$
30	Furnish and Install 6" DI Gate Valve w/ Valve Box and Cover	2	EA	\$	\$
31	Furnish & Install 4" Ductile Iron Pipe, CL 50 Including Trench Excavation, Backfill and Compaction	141	LF	\$	\$
32	Furnish and Install 4" DI Gate Valve w/ Valve Box and Cover	1	EA	\$	\$
33	Furnish and Intall 2" Rehau Municipex	219	LF	\$	\$
34	Furnish and Install Fire Hydrant Assembly	13	EA	\$	\$
35	Furnish and Install Concrete Block Wall	30	SF	\$	\$
36	Furnish and Install 2-inch Flushing Assembly	3	EA	\$	\$
37	Furnish and Install 1-inch Flushing Assembly	1	EA	\$	\$
38	Furnish and Install 1-inch Air/Vac Assembly	1	EA	\$	\$
39	Replace 5/8-inch Water Service, Short Rehau Municipex	55	EA	\$	\$
40	Replace 5/8-inch Water Service, Long Rehau Municipex	50	EA	\$	\$
41	Waterline Flushing, Pressure Testing, Disinfection and Bac-T testing	1	LS	\$	\$
42	Connection Work for Tie-In Sheet 7 at STA 80+35.5	1	LS	\$	\$
43	Connection Work for Tie-In Sheet 8 at STA 82+58	1	LS	\$	\$
44	Connection Work for Tie-In Sheet 8 at STA 43+70	1	LS	\$	\$
45	Connection Work for Tie-In Sheet 8 at STA 43+88	1	LS	\$	\$
46	Connection Work for Tie-In Sheet 8 at STA 73+74	1	LS	\$	\$

Item No.	Bid Schedule Description		Unit	Unit Price	Total
47	Connection Work for Tie-In Sheet 9 at STA 47+19	1	LS	\$	\$
48	Connection Work for Tie-In Sheet 9 at STA 47+47.5	1	LS	\$	\$
49	Connection Work for Tie-In Sheet 10 at STA 54+18.5	1	LS	\$	\$
50	Connection Work for Tie-In Sheet 13 at STA 76+17	1	LS	\$	\$
51	Connection Work for Tie-In Sheet 14 at STA 89+61	1	LS	\$	\$
52	Connection Work for Tie-In Sheet 14 at STA 90+49	1	LS	\$	\$
53	Connection Work for Tie-In Sheet 15 at STA 99+94	1	LS	\$	\$
54	Connection Work for Tie-In Sheet 16 at STA 108+25	1	LS	\$	\$
55	Connection Work for Tie-In Sheet 19 at STA 135+10	1	LS	\$	\$
56	Connection Work for Tie-In Sheet 20 at STA 208+11	1	LS	\$	\$
57	Connection Work for Tie-In Sheet 20 at STA 210+58	1	LS	\$	\$
58	Connection Work for Tie-In Sheet 21 at STA 211+59	1	LS	\$	\$
59	Connection Work for Tie-In Sheet 21 at STA 213+80	1	LS	\$	\$
60	Connection Work for Tie-In Sheet 22 at STA 228+04	1	LS	\$	\$
61	Connection Work for Tie-In Sheet 23 at STA 229+01	1	LS	\$	\$
62	Connection Work for Tie-In Sheet 25 at STA 282+00	1	LS	\$	\$
63	Connection Work for Tie-In Sheet 26 at STA 287+69.5	1	LS	\$	\$

**Sub-Total Bid SCHEDULE** \_\_\_\_\_

**Sales Tax (8.6%)** \_\_\_\_\_

**Total Bid Amount** \_\_\_\_\_

**DOLLARS**

\_\_\_\_\_ Total Bid Amount (written in words)

**PROPOSAL SIGNATURE, ADDENDUM ACKNOWLEDGEMENT AND NON-COLLUSION DECLARATION**

The bidder is hereby advised that by signature of this proposal he/she is deemed to have acknowledged all requirements and signed all certificates contained herein. The undersigned hereby agrees to pay to labor not less than the prevailing rates of wages or less than the hourly minimum rate of wages as specified in the Specifications and Conditions for this project. A proposal guarantee in an amount of five percent (5%) of the total bid not including sales tax, based upon the approximate estimate of quantities at the above prices and in the form as indicated below, is attached hereto:

CASH           \$ \_\_\_\_\_                           CASHIER'S CHECK           \$ \_\_\_\_\_  
BID BOND   \$ \_\_\_\_\_                           CERTIFIED CHECK           \$ \_\_\_\_\_

**Receipt is hereby acknowledged of Addenda # \_\_\_\_\_, \_\_\_\_\_, and \_\_\_\_\_.**

I, by signing the proposal, hereby declare, under penalty of perjury under the laws of the United States that the undersigned person(s), firm, association or corporation has (have) not, either directly or indirectly, entered into any agreement, participated in any collusion, or otherwise taken any action in restraint of free competitive bidding in connection with the project for which this proposal is submitted.

SIGNATURE OF AUTHORIZED OFFICIAL(S)

NOTE: Proposal must be signed

Signature \_\_\_\_\_

Firm Name \_\_\_\_\_

Address \_\_\_\_\_

\_\_\_\_\_

\_\_\_\_\_  
Washington State Contractor's License Number

Sworn to before me this \_\_\_\_\_ day of \_\_\_\_\_, 20\_\_\_\_

(SEAL)

NOTARY PUBLIC

## SUBCONTRACTORS LIST – RCW 39.30.060 FORM

In compliance with RCW 39.30.060 for all projects estimated to cost \$1 million or more, all Bidders must complete and submit this Subcontractors List form with their Bid Proposal.

List of Subcontractors: The Bidder shall indicate on the Subcontractors List the names of the subcontractors with whom the Bidder, if awarded the contract, will subcontract for performance of the work of heating, ventilation and air conditioning, plumbing as described in Chapter 18.106 RCW, and electrical as described in Chapter 19.28 RCW.

List Bidder if Bidder Performing Work: If the Bidder will perform the work in any of the three areas required, the Bidder shall name itself for the work on the Subcontractors List.

Name Only One Form for Each Category of Work: The Bidder shall not list more than one firm (subcontractor or Bidder) for each category of work identified, unless subcontractors vary with bid alternates or additive, in which case the Bidder must indicate which firm will be used for which alternate or additive.

Substitution of Subcontractors: Substitution of any listed subcontractor may only be according to the procedure and parameters set forth in RCW 39.30.060.

Factors relating to Non-Responsiveness: Failure of the Bidder to submit the names of such subcontractors, or to name itself to perform such work, or the naming of two or more firms (subcontractor or Bidder) to perform the same work shall render the Bidder’s bid non-responsive and, therefore, void.

Applicable to Direct Subcontractors: The requirement of this section to name the Bidders’ proposed heating, ventilation and air conditioning, plumbing and electrical subcontractors applies only to proposed heating, ventilation and air conditioning, plumbing and electrical subcontractors who will contract directly with the Bidder.

Submission Requirements: The Subcontractors List must be submitted with the Bid Proposal.

Trade	<b>Bidder must check one box for each Trade. If subcontracting the work, Bidder must name the subcontractor.</b>
HVAC (Heating, Ventilation and Air Conditioning)	<input type="checkbox"/> N/A (this project does not include this work) <input type="checkbox"/> Bidder will self-perform this work <input type="checkbox"/> Name and address of subcontractor <hr/> <hr/>
Plumbing	<input type="checkbox"/> N/A (this project does not include this work) <input type="checkbox"/> Bidder will self-perform this work <input type="checkbox"/> Name and address of subcontractor <hr/> <hr/>
Electrical	<input type="checkbox"/> N/A (this project does not include this work) <input type="checkbox"/> Bidder will self-perform this work <input type="checkbox"/> Name and address of subcontractor <hr/> <hr/>



Structural Steel Installation	<input type="checkbox"/> N/A (this project does not include this work) <input type="checkbox"/> Bidder will self-perform this work <input type="checkbox"/> Name and address of subcontractor <hr/> <hr/>
Rebar Installation	<input type="checkbox"/> N/A (this project does not include this work) <input type="checkbox"/> Bidder will self-perform this work <input type="checkbox"/> Name and address of subcontractor <hr/> <hr/>

**STATEMENT OF BIDDER'S QUALIFICATIONS**

**COMPARABLE CONTRACT HISTORY**

The following is a partial list of the last three jobs our organization completed which are similar in character to this project:

Year	Project Name	Pipe Diameter	Feet	Owner Rep.	Phone No.

Name of Company: \_\_\_\_\_

Address: \_\_\_\_\_

Telephone: \_\_\_\_\_

\_\_\_\_\_  
Date

\_\_\_\_\_  
Signature

\_\_\_\_\_  
Title

\_\_\_\_\_  
Contractor's License Number

**BID BOND**

KNOW ALL MEN BY THESE PRESENTS, that we, \_\_\_\_\_

Of \_\_\_\_\_

Hereinafter called the Contractor (Principal), and \_\_\_\_\_

a corporation duly organized and existing under and by virtue of the laws of the State of \_\_\_\_\_

hereinafter called the Surety, and authorized to transact business within the State of Washington as Surety,

are held and firmly bound unto Public Utility District No. 1 of Skagit County, Washington (Obligee) in the

full and penal sum of five percent (5%) of the total bid amount appearing on the bid proposal of said

principal for the work hereinafter described, for the payment of which, well and truly be made to the Owner,

the Contractor and the Surety bind themselves and each of their heirs, executors, administrators, successors,

and assigns, jointly and severally, firmly by these presents.

THE CONDITIONS OF THE ABOVE OBLIGATION ARE SUCH THAT WHEREAS, the Principal

herein is herewith submitting his or its bid proposal for **NORTH BURLINGTON PIPELINE**

**REPLACEMENT PROJECT.**

NOW THEREFORE, if the bid proposal submitted by the Principal is accepted, and the contract is awarded

to said Principal, and if said Principal shall duly make and enter into and execute said contract and shall

furnish the Performance and Payment Bond as required by the bidding and contract documents within a period

of ten (10) days from and after said award, exclusive of the day of such award, then its obligation to pay the

above-mentioned penal sum as liquidated damages shall be null and void, otherwise it shall remain and be in

full force and effect.

Signed and sealed this \_\_\_\_\_ day of \_\_\_\_\_, 20\_\_\_\_.

\_\_\_\_\_  
Contractor

\_\_\_\_\_  
Surety

By \_\_\_\_\_

By \_\_\_\_\_

Title \_\_\_\_\_

Corporate Seal

Corporate Seal

The Attorney-In-Fact who executes this bond on behalf of the Surety must attach a copy of his Power of Attorney as evidence of his authority.

# Certification of Compliance with Wage Payment Statutes

The bidder hereby certifies that, within the three-year period immediately preceding the bid solicitation date August 9, 2024, the bidder is not a “willful” violator, as defined in RCW 49.48.082, of any provision of chapters 49.46, 49.48, or 49.52 RCW, as determined by a final and binding citation and notice of assessment issued by the Department of Labor and Industries or through a civil judgment entered by a court of limited or general jurisdiction.

I certify under penalty of perjury under the laws of the State of Washington that the foregoing is true and correct.

---

Bidder

---

Signature of Authorized Official\*

---

Printed Name

---

Title

---

Date

---

City

---

State

*Check One:*

Individual  Partnership  Joint Venture  Corporation

State of Incorporation, or if not a corporation, State where business entity was formed:

---

If a co-partnership, give firm name under which business is transacted:

---

*\* If a corporation, proposal must be executed in the corporate name by the president or vice-president (or any other corporate officer accompanied by evidence of authority to sign). If a co-partnership, proposal must be executed by a partner.*

# **AGREEMENT**

**CONTRACT NO. XXXX**

THIS CONTRACT is made and entered into by and between the PUBLIC UTILITY DISTRICT NO. 1 OF SKAGIT COUNTY (Owner/Skagit PUD) and CONTRACTOR NAME (Contractor).

WITNESSETH:

WHEREAS, the Owner has caused the preparation of certain Contract Documents entitled **North Burlington Pipeline Replacement Project**.

WHEREAS, the Owner has invited proposals, has received and analyzed said proposals, and has duly given notice of Acceptance of Proposal to the Contractor herein set forth and as stated more in detail in the Contract Documents which are defined in Section II General Conditions, all of which Contract Documents are made a part hereof and which constitute the whole Contract between the Owner and the Contractor.

NOW, THEREFORE, it is hereby agreed that:

1. The Contractor shall furnish the work, pay all costs, and perform all requirements of this Contract in the manner specified in the Contract Documents, and;
2. The Proposal calls for unit prices and lump sums in the Bid Schedule(s) set forth in (1) above. The Owner shall pay to the Contractor a corrected Total Contract Amount computed from the unit prices and lump sums in said Bid Schedule(s) set forth in the Contractor's Proposal and the actual quantities of units furnished. Based upon the lump sum and unit prices in said Bid Schedule(s) set forth in the Contractor's Proposal and upon the quantities estimated from the Contract Drawings for bidding purposes, the estimated Total Contract Amount is (spell out dollar amount/100) Dollars (capitalize each word of the dollar amount) (\$ insert numeric dollar amount); and
3. In Washington State the Owner is required to pay state or local sales or use taxes included in the Total Contract Amount and the Contractor is required to receive the said taxes for payment to the state, the amount payable to the Contractor by the Owner shall be the Total Contract Amount as above specified including the amount of the said taxes, and;
4. It is further agreed that the Contractor will begin work after the Notice to Proceed is issued and shall be substantially complete by November 15, 2024, and;
5. In the event that the Contractor fails to substantially complete the Project by the date of substantial completion as specified above or as modified by Change Order, the Contractor shall be liable for liquidated damages of Five Hundred and 00/100 Dollars (\$500.00) per calendar day thereafter until the Owner determines the Project to be substantially complete, and;
6. The attached Indemnification Agreement is hereby made part of this Contract.

IN WITNESS WHEREOF, two identical counterparts of this Contract, each of which shall for all purposes be deemed an original hereof, have been duly executed by the parties hereto.

(CONTRACTOR name here)

PUBLIC UTILITY DISTRICT NO. 1  
OF SKAGIT COUNTY, WASHINGTON

By \_\_\_\_\_  
(Name, Title here)

By \_\_\_\_\_  
George Sidhu, P.E., General Manager

Date \_\_\_\_\_

Date \_\_\_\_\_

**INDEMNIFICATION AGREEMENT**

The Contractor agrees to defend, indemnify, and hold Skagit PUD harmless from any and all claims, demands, losses, and liabilities to or by third parties arising from, resulting from, or connected with work performed or to be performed under this Contract by the Contractor, its agents, employees, and subcontractors, even though such claims may prove to be false, groundless or fraudulent, to the fullest extent permitted by law and subject to the limitations provided below.

The Contractor's duty to indemnify Skagit PUD shall not apply to liability for damages arising out of bodily injury to persons or damage to property caused by or resulting from the sole negligence of Skagit PUD or Skagit PUD's agents or employees. The Contractor's duty to indemnify Skagit PUD for liability for damages arising out of bodily injury to persons or damage to property caused by or resulting from the concurrent negligence of Contractor, its agents, employees, or subcontractors and/or Skagit PUD or Skagit PUD's agents or employees, shall apply only to the extent of negligence of Contractor, its agents, employees, or subcontractors.

With respect to claims against Contractor by Skagit PUD pursuant to this Contract only, Contractor expressly waives any immunity that may be granted it under the Workers' Compensation, Industrial Insurance or like statutes and/or any administrative regulations issued pursuant thereto. This waiver does not include or extend to any claims by Contractor's employees directly against Contractor.

Further, Contractor's defense and indemnification obligations under this Contract shall not be limited in any way by any limitation on the amount or type of damages, compensation or benefits payable to or for any third party under Workers' Compensation, Industrial Insurance or like statutes and/or any administrative regulations issued pursuant thereto.

Contractor's duty to indemnify Skagit PUD for liabilities or losses, other than for bodily injury to persons or damage to property caused by or resulting from negligence, shall apply only to the extent of the fault of Contractor, its agents, employees, or subcontractors, except in situations where fault is not a requirement for liability, in which case indemnity will be provided to the extent the liability or loss was caused by Contractor or its agents, employees, or subcontractors.

Contractor's duty to defend, indemnify and hold Skagit PUD harmless shall include, as to all claims, demands, losses and liabilities to which it applies, Skagit PUD's actual attorneys' fees and costs incurred in connection with defending such claim(s) including, without limitation, consultant and expert witness fees and expenses and personnel-related costs in addition to costs otherwise recoverable by statute or court rule.

**THE UNDERSIGNED HEREBY CERTIFY THAT THIS AGREEMENT WAS MUTUALLY NEGOTIATED.**

(CONTRACTOR name here)

PUBLIC UTILITY DISTRICT NO. 1  
OF SKAGIT COUNTY, WASHINGTON

By: \_\_\_\_\_  
(Name, Title here)

By: \_\_\_\_\_  
George Sidhu, P.E., General Manager

Dated: \_\_\_\_\_

Dated: \_\_\_\_\_

The Contractor shall cause each of its subcontractors (and suppliers to the extent any perform any work on the Project site) to execute an Indemnification Contract substantially in the form of the foregoing by which each such entity or person assumes to Skagit PUD all obligations Contractor assumes to Skagit PUD as set forth above.



**Certificate of Owner’s Attorney**

I, the undersigned, **Peter Gilbert**, the duly authorized and acting legal representative of Public Utility District No. 1 of Skagit County, do hereby certify as follows

I have examined the attached contract(s) and the manner of execution thereof, and I am of the opinion that each of the aforesaid agreements are adequate and have been duly executed by the proper parties thereto acting through their duly authorized representatives; that said representatives have full power and authority to execute said agreements on behalf of the respective parties named thereon; and that the foregoing agreements constitute valid and legally binding obligations upon the parties executing the same in accordance with terms, conditions, and provisions thereof.

---

Peter Gilbert, Attorney

Date: \_\_\_\_\_

**PERFORMANCE AND PAYMENT BOND**

Bond No. \_\_\_\_\_  
Amount: \$ \_\_\_\_\_

KNOW ALL MEN BY THESE PRESENTS, that

Of \_\_\_\_\_  
Hereinafter called the Contractor (Principal), and \_\_\_\_\_

a corporation duly organized and existing under and by virtue of the laws of the State of \_\_\_\_\_ hereinafter called the Surety, and authorized to transact business within the State of Washington as Surety, are held and firmly bound unto Public Utility District No. 1 of Skagit County, Washington as Owner (Obligee), in the sum of \_\_\_\_\_ Dollars (\$ \_\_\_\_\_), lawful money of the United States of America, for the payment of which, well and truly be made to the Owner, the Contractor and the Surety bind themselves and each of their heirs, executors, administrators, successors, and assigns, jointly and severally, firmly by these presents as follows:

THE CONDITIONS OF THE ABOVE OBLIGATION ARE SUCH THAT:

WHEREAS, the Contractor has executed and entered into a certain Contract hereto attached, with the Owner, dated \_\_\_\_\_, 20\_\_\_\_.

For: \_\_\_\_\_

IN WITNESS: NOW THEREFORE, if Contractor, its heirs, executors, administrators, successors, or assigns, shall in all things stand to and abide by, and well and truly keep and perform the covenants, conditions and agreements in the said Contract for the duration thereof, including the one-year warranty period, and shall also well and truly perform and fulfill all the undertakings, covenants, terms, conditions and agreements of any and all duly authorized modifications of said Contract that may hereafter be made, at the time and in the manner therein specified and shall pay all laborers, mechanics, subcontractors or lower tier subcontractors, and material persons, and all persons who shall supply such person or persons, or subcontractors or lower tier subcontractors, with provisions and supplies for the carrying on of such work, on his or their part, and shall indemnify and save harmless Owner, its officers and agents, then this obligation shall become null and void; otherwise, it shall be and remain in full force and effect.

And Surety, for value received, hereby further stipulates and agrees that no change, extension of time, alteration or addition to the terms of Contract or to the work to be performed thereunder or the plans or specifications accompanying the same shall in any way affect its obligation of this Bond, and it does hereby waive notice of any change, extension of time, alterations or additions to the terms of the Contract, the plans or the specifications.

Surety hereby agrees that modifications and changes may be made in the terms and provisions of the Contract without notice to Surety, and any such modifications or changes increasing the total amount to be paid the Contractor shall automatically increase the obligation of the Surety on this Bond in a like amount.

The Surety expressly acknowledges that it shall be liable, under this Bond, for any liquidated damages assessed against the Contractor in accordance with the provisions of the Contract.

Any claim(s) relating to or against this Bond shall be subject to and decided by arbitration in accordance with the provisions of the Revised Code of Washington Chapter 7.04.

Any dispute relating to the performance or enforcement of the provisions of this Bond shall be governed by Washington State Law. Jurisdiction and venue shall be Skagit County Courts. If non-binding arbitration or mediation is conducted involving the Owner, the Contractor, the Surety, or any other party concerning or in any way relating the work required or alleged to be required by the Contract, the Contractor and Surety expressly consent to a consolidated or joint arbitration if and as called for by the Owner. The prevailing party in each such litigation shall be entitled to recover its attorneys' fees, in addition to any other relief granted.

IN WITNESS WHEREOF, the Contractor and the Surety have caused this bond and two (2) counterparts thereof to be signed and sealed by their duly authorized officers.

Signed and sealed this \_\_\_\_\_ day of \_\_\_\_\_, 20\_\_\_\_.

\_\_\_\_\_  
Contractor

\_\_\_\_\_  
Surety

By \_\_\_\_\_

By \_\_\_\_\_

Attorney-In-Fact

Title \_\_\_\_\_

Corporate Seal

Corporate Seal

Address of local office and agent of Surety  
Company:

\_\_\_\_\_  
\_\_\_\_\_  
\_\_\_\_\_  
\_\_\_\_\_

APPROVED AS TO FORM:

\_\_\_\_\_, Owner \_\_\_\_\_, 20\_\_\_\_

This Bond is executed in pursuance of Chapter 39.08, Revised Code of Washington.

NOTE: The Surety named on this Bond shall be one which is licensed to conduct business in the state where the project is located, and named in the current list of Companies Holding Certificates of Authority as Acceptable Sureties on Federal Bonds and as Acceptable Reinsuring Companies, as published in Circular 570 (amended) by the Audit Staff Bureau of Accounts, U.S. Treasury Department. All Bonds signed by an agent must be accompanied by a certified copy of the authority to act for the Surety at the time of the signing of this Bond.

Corporate Seal:

CERTIFICATE AS TO CORPORATE SEAL

I hereby certify that I am the (Assistant) Secretary of the Corporation named as Principal in the within Bond; that \_\_\_\_\_ who signed the said Bond on behalf of the Principal, was \_\_\_\_\_ of said Corporation; that I know his signature thereto is genuine, and that said Bond was duly signed, sealed, and attested for and in behalf of said Corporation by authority of its government body.

\_\_\_\_\_  
Secretary or Assistant Secretary

**ATTACH POWER OF ATTORNEY**

# **GENERAL CONDITIONS**

# **GENERAL CONDITIONS**

## **NOTICE OF DISCLAIMER**

TAKE NOTICE, that the General Conditions are the 2024 Edition of the Washington State Department of Transportation Standard Specifications for Road, Bridge and Municipal Construction.

TAKE NOTICE, that these General Conditions have been materially amended by certain additions, deletions or other modifications to meet the needs of the Public Utility District No. 1 of Skagit County. These amendments are contained in the Supplementary General Conditions.

**END OF SECTION**

**SUPPLEMENTARY GENERAL  
CONDITIONS**

## SUPPLEMENTARY GENERAL CONDITIONS

The following provisions of the Washington State 2024 Standard Specifications for Road, Bridge, and Municipal Construction (WSDOT) Division 1 General Requirements is hereby amended, changed, or supplemented and superseded as follows. All other provisions which are not amended, changed, or supplemented remain in full force.

1	Order of Precedence	
2	Section 1-01.3	Definitions
3	Section 1-03	Award and Execution of Contract
3.1	Section 1-03.4	Contract Bond
3.2	Section 1-03.8	Award and Execution of Contract
4	Section 1-05	Control of Work
4.1	Section 1.05.0	General
4.2	Section 1-05.4	Conformance with and Deviations from Plans and Stakes
4.3	Section 1-05.10	Guarantees
5	Section 1-07	Legal Relations and Responsibilities to the Public
5.1	Section 1-07.1(1)	Laws to be Observed
5.2	Section 1-07.6	Permits and Licenses
5.3	Section 1-07.18(1)	Public Liability and Property Damage Insurance
5.4	Section 1-07.26	Personal Liability of Public Officers
6	Section 1-08	Prosecution and Progress
6.1	Section 1-08.5	Time for Completion (Contract Time)
6.2	Section 1.08.9	Liquidated Damages
6.3	Section 1.08.10(2)	Termination for Public Convenience
7	Section 1-09	Measurement and Payment
7.1	Section 1-09.4	Equitable Adjustment
7.2	Section 1-09.6	Force Account
7.3	Section 1-09.11(3)	Time Limitations and Jurisdiction
7.4	Section 1-09.13(3)	Claims Resolution
7.5	Section 1-09.14	Claims Against Contractor's Retainage and/or Public Contract Bond
8	Section 1-10	Temporary Traffic Control
8.1	Section 1-10.2(2)	Traffic Control Plans

**1 ORDER OF PRECEDENCE. THE ORDER OF PRECEDENCE OF THE CONDITIONS OF THE CONTRACT ARE AS LISTED BELOW, FIRST IS THE HIGHEST AND LAST IS THE LOWEST:**

Addenda  
Bid Forms  
Technical Specifications  
Drawings  
Special Provisions  
Supplementary General Conditions  
Division 1 General Requirements (WSDOT) 2024 Edition



**2 SECTION 1-01.3 DEFINITIONS IS SUPPLEMENTED BY ADDING THE FOLLOWING DEFINITIONS:**

Whenever these words are used in the Contract Documents, they shall have the following meanings:

"COMMISSION": Redefined to mean the three elected Commissioners of Skagit PUD; substitute for "Commission" and "Washington State Transportation Commission" whenever cited.

"CONTRACTING AGENCY", "DISTRICT" or "OWNER": Public Utility District No. 1 of Skagit, Washington; substitute for "State," "Department," and "Department of Transportation" whenever cited.

"GENERAL MANAGER": The person appointed by the Commission per RCW 54.16.100 as the chief administrative officer of Skagit PUD; substitute for "Secretary" and "Secretary of Transportation" whenever cited.

"ENGINEER": Public Utility District No. 1 of Skagit County and its sub consultants.

"STANDARD PLANS": Redefined to refer to the Standard Detail Sheets included with the Plans and Specifications as well as the WSDOT Standard Plans. The requirements of the Standard Detail Sheets shall be controlling in the case of any discrepancy between the Standard Details and the WSDOT Standard Plans.

**3 SECTION 1-03 AWARD AND EXECUTION OF CONTRACT IS SUPPLEMENTED BY ADDING THE FOLLOWING:**

**3.1 Add the following to Section 1-03.4, Contract Bond:**

Upon substantial completion of the Project, the Contractor shall provide a Utility Maintenance Bond for 25% of the Total Contract Amount on the form specified by Skagit PUD that warrants all equipment, materials, and labor it furnishes or performs under the Agreement against defects in design, materials, and workmanship for one (1) year after final acceptance as described in Section 1-05.10.

**3.2 Add the following new Section 1-03.8 Award and Execution of Contract:**

1-03.8 Award and Execution of Contract.

1-03.8(1) The Contract for the Project shall be awarded to the responsible Bidder submitting the lowest responsive Bid. The lowest responsive Bid shall be determined by the total of the amount of the base Bid and the amount(s) Bid for any alternate(s) which the Owner, in its discretion, elects to include in the Contract.

**4 SECTION 1-05 CONTROL OF WORK IS REVISED AS FOLLOWS:**

**4.1 Insert the following new Section 1-05.0 General:**

1-05.0 General

Where the Specifications, the Owner's instructions, laws, ordinances, or any government authority require any work to be specially tested, or inspected, the Contractor shall give the Owner timely notice that such test of completed work is ready for inspection. If the inspection is by another authority than the Owner, the Contractor shall give the Owner timely notice of the date fixed for such inspection. Required certificates of inspection by other authority than the Owner shall be secured by the Contractor.

**4.2 Revise Section 1-05.4, Conformance with And Deviation from Plans and Stakes, as follows:**

Delete the word “Engineer” and replace with “Contractor” throughout this section with reference to setting stakes, marks, lines, etc. for the layout and prosecution of the Work. All surveying and layout required for this Project shall be performed by the Contractor. The Engineer retains final authority for determination of conformity of the Work and shall be notified immediately of any errors found to cause deviations in the Work.

**4.3 Delete Section 1-05.10, Guarantees, and replace with the following:**

1-05.10 Guarantees

The Contractor shall furnish to the Contracting Agency any guarantee or warranty furnished as a normal trade practice in connection with the purchase of any equipment, materials, or items used in the construction of the project.

The Contractor shall be responsible for correcting all defects in workmanship and materials incurred within one year (365 days) after the date of final acceptance of the project. When corrections of defects are made, the Contractor shall be responsible for correcting all defects in workmanship and/or materials in the corrected Work for one year after acceptance of the correction by the Owner. The Contractor shall commence remedying such defects within seven (7) days of receipt of notice of discovery thereof from the Owner and shall complete such Work within a reasonable time. In emergencies, where damage may result from delay or where loss of service may result, such corrections may be made by the Owner, in which case the cost shall be borne by the Contractor. In the event the Contractor does not complete corrections within a reasonable time, the Work shall be otherwise accomplished and the cost of same shall be paid by the Contractor.

The Contractor shall be liable for any costs, losses, expenses, or damages, including consequential damages, suffered by the Owner resulting from defects in the Contractor's Work including but not limited to costs, labor, materials, equipment, and administration

incurred by Owner in making emergency repairs of such defective Work and associated costs of engineering, inspection, and supervision by the Owner or Engineer. The Contractor shall defend, indemnify and hold the Owner harmless from any and all claims which may be made against the Owner as a result of Contractor's defective Work.

**5 SECTION 1-07 LEGAL RELATIONS AND RESPONSIBILITIES TO THE PUBLIC IS SUPPLEMENTED BY ADDING THE FOLLOWING:**

**5.1 Add the following Section 1-07.1(1) Owner Safe Access:**

**1-07.1(1) Owner Safe Access.**

The Contractor shall provide safe access for the Owner and its inspectors to adequately inspect the quality of work and the conformance with Contract Documents. The Contractor shall provide adequate lighting, ventilation, ladders, and other protective facilities as may be necessary for the safe performance of inspections.

**5.2 Add the following to Section 1-07.6, Permits and Licenses:**

The Contractor shall comply with all requirements of all permits provided by the Owner for this project.

**5.3 Add the following to Section 1-07.9, Wages, 1-07.9(1), General:**

Current Washington State Department of Labor and Industries prevailing wage rates are available at:

<https://secure.lni.wa.gov/wagelookup/>

Wage rates applicable for this project are those for Skagit County with an effective date of this Contract Bid Date and attached in Appendix A.

**5.4 Revise Section 1-07.18, Public Liability and Property Damage Insurance as follows:**

All reference to the State or Department of Transportation shall be supplanted with Public Utility District No. 1 of Skagit County.

**5.5 Revise Section 1-07.26, Personal Liability of Public Officers, as follows:**

Neither the Owner nor any elected official, officer, or its employees shall be personally liable for any acts or failure to act in connection with the Contract, it being understood that in such manners, they are acting solely as agents of the Owner.

No right of action shall accrue upon or by reason of this Contract to or for the use or benefit of anyone other than the parties to this Contract. The parties to this Contract are the Contractor and the Owner.

**6 SECTION 1-08, PROSECUTION AND PROGRESS, IS REVISED AS FOLLOWS:**

**6.1 Supplement Section 1-08.5, Time for Completion (Contract Time), with the following:**

Contractor shall complete all work associated with the Bid Schedule utilizing a finish date of November 15, 2024.

**6.2 Section 1-08.9, Liquidated Damages replaced numbered paragraphs 1 and 2 with the following:**

1. To pay liquidated damages for each working day beyond the number of days established for substantial completion, to authorize the Owner to deduct these liquidated damages from any money due or coming due to the Contractor.

**6.3 Revise Section 1-08.10(2), Termination for Public Convenience, as follows:**

Substitute "Resolution" for "Executive Order", substitute "Commission" for "President", and delete "or Governor".

**7 SECTION 1-09, MEASUREMENT AND PAYMENT, IS REVISED AS FOLLOWS:**

**7.1 Supplement Section 1-09.4, Equitable Adjustment, with the following:**

All bilateral agreements shall constitute a full accord and satisfaction and represent payment in full as to adjustments in both Contract price and time of completion for all costs, whether direct or indirect, arising out of, or incidental to, or otherwise attributable to, the changed work including any and all delays and impacts resulting from the change to the contract. Acceptance of payment by Contractor pursuant to such bilateral agreement shall constitute a waiver of any and all claims, known or unknown, arising out of, or incidental to, or otherwise attributable to the changed work.

**7.2 Revise Section 1-09.6, Force Account, as follows:**

Revise Item No. 1 as follows: Substitute "21 Percent" for "29 percent" for Contractor's allowance for overhead and profit.

**7.3 Revise Section 1-09.11(3), TIME LIMITATIONS AND JURISDICTION**

Revise as follows: Substitute Public Utility District No.1 of Skagit County for State of Washington (six times). Substitute Superior Court of Skagit County for Superior Court of Thurston County.

**7.4 Replace Sections 1-09.13(3), (3)A, (3)B and (4), Claims Resolution, with the following:**

**CLAIMS 1-09.13(3)**

The Contractor and Contracting agency mutually agree that claims submitted in accordance with Section 1-09.11 and not resolved by nonbinding ADR process, shall be resolved by litigation unless the Contracting agency elects to resolve the claim through binding arbitration.

**Venue.** The venue of any Dispute Resolution Proceedings between the parties to this Agreement shall be Mount Vernon, Washington unless otherwise mutually agreed in writing.

**Injunctive Proceedings.** Notwithstanding any other provisions of these Dispute Resolution Procedures, any Disputes otherwise subject to submission to these Dispute Resolution Procedures may instead be first submitted, by any party having a legal interest therein, to the jurisdiction of the Superior Court for Skagit County, State of Washington, if and only to the extent necessary to secure injunctive relief reasonably necessary under the circumstances.

**7.5 Add the following new Section 1-09.14 Claims Against Contractor's Retainage and/or Public Contract Bond:**

**1-09.14 Claims Against Contractor's Retainage and/or Public Contract Bond**

The Contractor shall be liable for all costs incurred by the Owner, including, but not limited to, legal fees, salary/wage costs of Owner's employees and litigation costs (whether or not recoverable by statute or court rule) arising out of claims against the retainage or the Contractor's Public Contract Bond. Owner may deduct any such costs from funds otherwise due the Contractor, including the retention, by unilateral Change Order.

**8 SECTION 1-10, TEMPORARY TRAFFIC CONTROL, IS REVISED AS FOLLOWS:**

**8.1 Revise Section 1-10.2(2), Traffic Control Plans, as follows:**

Delete the first sentence of Section 1-10.2(2) and replace with the following:  
Skagit PUD is providing an approved traffic control plan for the project that the Contractor will implement to handle traffic safety during construction.

END OF SECTION

# D I V I S I O N 1

## GENERAL REQUIREMENTS

## SECTION - 01010

### SUMMARY OF WORK

#### PART 1 GENERAL

##### 1.1 THE REQUIREMENT

- A. The Work to be performed under this Contract shall consist of furnishing tools, equipment, materials, supplies, and manufactured articles, and furnishing all labor, transportation, and services, including fuel, power, water, and essential communications, and performing all work or other operations required for the fulfillment of the Contract in strict accordance with the Contract Documents. The Work shall be complete, and all work, materials, and services not expressly indicated or called for in the Contract Documents which may be necessary for the complete and proper construction of the WORK in good faith shall be provided by the CONTRACTOR as though originally so indicated, at no increase in cost to the OWNER.

##### 1.2 WORK COVERED BY CONTRACT DOCUMENTS

- A. The Work of this Contract is as follows:

Installation of approximately 7,550 linear feet of water distribution piping along Hazel Avenue, North Walnut Street, Avon Avenue, Magnolia Avenue, North Oak Street, North Cherry Street, North Pine Street, North Anacortes Street, South Walnut Street, and South Alder Street in the City of Burlington, State of Washington, consisting of 8-inch, 6-inch and 4-inch diameter Ductile Iron piping including fittings, thrust blocks, service connections, fire hydrants, branch and mainline valves, establishment of private water service connections, dewatering, appurtenances and incidentals, pavement repair, abandonment of existing valves in place, temporary traffic control, temporary erosion control, disinfection, and pressure testing, in estimated quantities identified in the Bid Proposal and as shown on the plans.

##### 1.3 WORK BY OTHERS

- A. The CONTRACTOR's attention is directed to the fact that work may be conducted along the project routes by other contractors during the performance of the Work under this Contract. The CONTRACTOR shall conduct its operations so as to cause a minimum of interference with the work of such other contractors and shall cooperate fully with such contractors to allow continued safe access to their respective portions of the Site, as required to perform work under their respective contracts.
- B. **Interference With Work On Utilities:** The CONTRACTOR shall cooperate fully with all utility forces of the OWNER or forces of other public or private agencies engaged in the relocation, altering, or otherwise rearranging of any facilities which interfere with the progress of the Work, and shall schedule the Work so as to minimize interference with said relocation, altering, or other rearranging of facilities.

##### 1.4 CONTRACTOR USE OF SITE

- A. The CONTRACTOR's use of the Site shall be limited to its construction operations. No arrangements have been made for on-site storage of materials or field offices.

##### 1.5 PROJECT MEETINGS

A. **Preconstruction Conference:**

1. Prior to the commencement of Work, a preconstruction conference will be held at Skagit PUD's office at a mutually agreed time. The conference shall be attended by the CONTRACTOR's Project Manager, its superintendent, and its Subcontractors as the CONTRACTOR deems appropriate. Other attendees will be:
  - a. OWNER and OWNER representatives.
  - b. Governmental representatives as appropriate.

- c. Others as requested by CONTRACTOR, OWNER, or ENGINEER.
2. The CONTRACTOR shall bring to the preconstruction conference submittals in accordance with Section 01300.
3. The purpose of the conference is to designate responsible personnel and establish a working relationship. Matters requiring coordination will be discussed and procedures for handling such matters established. The complete agenda will be furnished to the CONTRACTOR prior to the meeting date. However, the CONTRACTOR should be prepared to discuss all of the items listed below.
  - a. Status of CONTRACTOR's insurance and bonds.
  - b. CONTRACTOR's tentative schedules.
  - c. Transmittal, review, and distribution of CONTRACTOR's submittals.
  - d. Processing applications for payment.
  - e. Maintaining record documents.
  - f. Critical work sequencing.
  - g. Field decisions and Change Orders.
  - h. Use of Site, office and storage areas, security, housekeeping, and OWNER's needs.
  - i. Major equipment deliveries and priorities.
  - j. CONTRACTOR's assignments for safety and first aid.
  - k. CONTRACTOR's Daily Report Form.
  - l. Request for Information (RFI) Form, which is appended at the end of this section.
  - m. Substitution Request Form.
  - n. 24-hour emergency contact information for OWNER and CONTRACTOR.
4. The OWNER will preside at the preconstruction conference and will arrange for keeping and distributing the minutes to all persons in attendance.
5. The CONTRACTOR and its Subcontractors should plan on the conference taking no less than 2 hours. The meeting will cover the items listed in paragraphs 2 and 3, and review of the Drawings and Specifications, with the OWNER.

**B. Progress Meetings:**

1. Progress meetings will be held as requested by the OWNER or the CONTRACTOR, as required depending on the progress of work.
2. The OWNER will preside at the progress meetings and will arrange for keeping and distributing the minutes. The purpose of the meetings is to review the progress of the WORK, maintain coordination of efforts, discuss changes in scheduling, address outstanding RFIs and submittals, discuss pending change orders and progress payments, and resolve other problems that may develop. During each meeting, the CONTRACTOR shall present any issues that may impact its progress with a view to resolving these issues expeditiously.

**PART 2 PRODUCTS (NOT USED)**

**PART 3 EXECUTION (NOT USED)**

**END OF SECTION**





Log No.

**Owner:** \_\_\_\_\_

**Contractor:** \_\_\_\_\_

**Project:** \_\_\_\_\_

**Project No.** \_\_\_\_\_

(FOR CONTRACTOR'S USE)

DATE:

SUBJECT:

DESCRIPTION:

CONTRACTOR'S AUTHORIZED SIGNATURE:

(FOR ENGINEER'S USE)

DATE:

SUBJECT:

DESCRIPTION:

ENGINEER'S AUTHORIZED SIGNATURE

**Distribution:**

- 1. Contractor
- 2. Owner
- 3. Project Manager
- 4. Construction Manager
- 5. Project Files

**SECTION - 01025  
MEASUREMENT AND PAYMENT**

**PART 1 GENERAL**

**1.1 SCOPE**

- A. Payment for the various items in the Proposal, as further specified herein, shall include all compensation to be received by the CONTRACTOR for furnishing all tools, equipment, supplies, and manufactured articles, and for all labor, operations, and incidentals appurtenant to the items of work being described, as necessary to complete the various items of the WORK all in accordance with the requirements of the Contract Documents, including all appurtenances thereto, and including all costs of permits and cost of compliance with the regulations of public agencies having jurisdiction, including Safety and Health Requirements of the Occupational Safety and Health Administration of the U.S. Department of Labor (OSHA) and the State of Washington, Division of Industrial Safety and Health (WISHA). No separate payment will be made for any item that is not specifically set forth in the Proposal or in this Section 01025, and all costs therefore shall be included in the prices named in the Proposal for the various appurtenant items of work.
- B. Payment shall only be made for items listed in the Proposal or as listed in executed change orders. References in the Contract Documents to the 2024 Standard Specifications (of the Washington State Department of Transportation) are for purposes of defining products or execution of the WORK, but payment provisions of the 2024 Standard Specifications do not apply unless specifically incorporated by reference in these Contract Documents.

**1.2 ITEM 1 – MOBILIZATION**

- A. No measurement of Mobilization shall be made.
- B. Payment for Mobilization will be by the lump sum price named in the Proposal. Payment shall be made according to the schedule of payments stated in Section 1-09.7 of the WSDOT 2024 Standard Specifications.

**1.3 ITEM 2 – CONTRACTOR’S ACCIDENT PREVENTION PROGRAM AND SITE SPECIFIC HEALTH AND SAFETY PLAN**

- A. No measurement of Contractor’s Accident Prevention Program and a Site Specific Health and Safety Plan shall be made.
- B. The Contractor’s Accident Prevention Program and a Site Specific Health and Safety Plan shall be by the lump sum price named in the Proposal, which price shall constitute full payment for all tools, equipment, labor, and materials required to complete this work as specified herein; including but not limited to incidentals necessary to implement the plan as specified in accordance with requirements of the Contract Documents.
- C. Payment will be made at 90 percent of the lump sum price after receipt and review of the plan and the remaining payment will be at substantial completion.

**1.4 ITEM 3 –SPCC AND TESC PLAN**

- A. No measurement of SPCC and TESC Plan shall be made.
- B. Payment for Spill Prevention Control and Countermeasures Plan (SPCC) and Temporary Erosion and Sediment Control Plan (TESC) shall be by the lump sum price named in the Proposal, which price shall constitute full payment for all tools, equipment, labor, and materials required to complete this work as

specified herein; including but not limited to incidentals necessary to implement the plans as specified in accordance with requirements of the Contract Documents.

- C. Payment will be made at 50 percent of the lump sum price after receipt and review of the plan, and the remaining payment will be at substantial completion.

#### **1.5 ITEM 4 – ESC LEAD**

- A. No measurement for ESC Lead shall be made.
- B. Payment for ESC Lead shall be by the lump sum price named in the Proposal, which price shall constitute full payment for all tools, equipment, labor, and materials required to complete this work as specified in section 8-01.3(1)B of the Standard Specification and as specified herein; including but not limited to each day an inspection is made and a report is generated and filed in accordance with requirements of the Contract Documents.

#### **1.6 ITEM 5 – INSTALL AND MAINTAIN TEMPORARY EROSION CONTROL AND WATER POLLUTION CONTROL MEASURES**

- A. No measurement of Install and Maintain Temporary Erosion Control and Water Pollution Control Measures shall be made.
- B. Payment for Install and Maintain Temporary Erosion Control and Water Pollution Control Measures shall be by the lump sum price named in the Proposal, which payment shall be considered full compensation for all tools, equipment, labor, and materials required to complete this work as specified herein; including but not limited to the establishment, maintenance, and removal of temporary erosion and water pollution control measures in accordance with requirements of the Contract Documents.
- C. Eighty percent of the lump sum unit price will be dispersed according to an agreed upon schedule of value earned, while the remaining twenty percent of the lump sum price will be paid after final site stabilization and removal of erosion control measures.

#### **1.7 ITEM 6 – TRAFFIC CONTROL SUPERVISOR**

- A. Measurement of Traffic Control Supervisor shall be by number of days the Traffic Control Supervisor is on site and for which has completed a Contractor's Daily Report of Traffic Control.
- B. Payment for Traffic Control Supervisor shall be by the unit price per day named in the Proposal, which price shall constitute full payment for all tools, equipment, labor, and materials required to complete this work as specified herein; including but not limited to completion of Contractor's Daily Report of Traffic Control – Summary and Traffic Control Logs in accordance with requirements of the Contract Documents, Flagging, and Maintaining Traffic Control.
- C. Traffic Control Supervisor will be paid as a Traffic Control Supervisor and not a flagger. A Traffic Control Supervisor is required for all hours worked when temporary traffic control measures are present.

#### **1.8 ITEM 7 – FLAGGERS**

- A. Measurement of Flaggers shall be by the number of hours flagging is actually taking place. Traffic Control Supervisor performing flagging duties will not be measured under this unit of pay.
- B. Payment for Flaggers shall be by the unit price per hour named in the Proposal, which payment shall constitute full payment for all tools, equipment, labor, and materials required to complete this work as specified herein; including but not limited to traffic control in accordance with requirements of the Contract Documents.

## **1.9 ITEM 8 - TRAFFIC CONTROL SIGNS AND DEVICES**

- A. No measurement of Traffic Control Signs and Devices shall be made.
- B. Payment for Traffic Control Signs and Devices shall be by the lump sum price named in the Proposal, which price shall constitute full payment for all tools, equipment, labor, and materials required to complete this work as specified herein; including but not limited to furnishing Class “A” & “B” Traffic Control Signs and Devices and take down of all Traffic Control Signs and Devices in accordance with requirements of the Contract Documents.
- C. Schedule of payment for Traffic Control Signs and Devices shall be based on percentage of project completion.

## **1.10 ITEM 9 –FURNISH PORTABLE CHANGEABLE MESSAGE SIGN(S) (PCMS)**

- A. Measurement of Furnish Portable Changeable Message Sign(s) (PCMS) shall be by the number of days display(s) is/are required, as determined by the Engineer, and in use. Measurement shall be to the nearest half-day. No measurement shall be made for mobilization of the sign(s) on site or within the project limits or when the sign(s) is/are not in use.
- B. Payment for PCMS shall be by the unit price per day named in the Proposal, which price shall constitute full payment for all tools, equipment, labor, and materials required to complete this work as specified herein in accordance with requirements of the Contract Documents.

## **1.11 ITEM 10 – FURNISH AND INSTALL ADEQUATE SITE AND TRENCH SAFETY SYSTEMS IN ACCORDANCE WITH CHAPTER 49.17 RCW**

- A. Measurement of Furnish and Install Adequate Site and Trench Safety Systems shall be by the number of linear feet of trench shoring actually installed, regardless of the number of faces shored, as determined by horizontal measurement along the pipe centerline.
- B. Payment for Furnish and Install Adequate Site and Trench Safety System shall be by the unit price per linear foot named in the Proposal, which price shall constitute full payment for all tools, equipment, labor, and materials required to complete this work as specified herein; including but not limited to the setup and take down of all site and trench safety systems in accordance with requirements of the Contract Documents.

## **1.12 ITEM 11 – SAWCUT PAVEMENT FOR PERMANENT PATCH**

- A. Measurement of Sawcut Pavement for Permanent Patch shall be by the unit price per linear foot as measured along each line of sawcut pavement, regardless of depth, for sawcuts made in preparation of HMA permanent patching; only one measurement will be made.
- B. Payment for Sawcut Pavement for Permanent Patch shall be by the unit price per linear foot named in the Proposal, which payment shall constitute full payment for all tools, labor, equipment, and materials required to complete this work as specified herein; including but not limited to compliance with storm water and environmental regulations in accordance with requirements of the Contract Documents.

**1.13 ITEM 12 – FURNISH AND INSTALL ENGINEER-ORDERED TRENCH STABILIZATION MATERIAL**

- A. Measurement of Furnish and Install Engineer-Ordered Trench Stabilization Material shall be by the number of tons placed in the trench, based on truck scale ticket weights.
- B. Payment for Furnish and Install Engineer-Ordered Trench Stabilization Material shall be by the unit price per ton named in the Proposal, which price shall constitute full payment for all tools, equipment, labor, and materials required to complete this work as specified herein; including but not limited to furnishing, placing and compacting the trench stabilization materials, and for filter fabric around the stabilization material in accordance with requirements of the Contract Documents.

**1.14 ITEM 13 – FURNISH AND INSTALL ENGINEER-ORDERED OVER EXCAVATION**

- A. Measurement of Furnish and Install Engineer-Ordered Over Excavation shall be by the number of cubic yards of engineer ordered over excavation as measured by neat lines.
- B. Payment for Furnish and Install Engineer-Ordered Over Excavation shall be by the unit price per cubic yard named in the Proposal, which price shall constitute full payment for all tools, equipment, labor, and materials required to complete this work as specified herein; including but not limited to excavating and removing and disposed of unsuitable material below the bottom of the trench and placement of separation fabric in accordance with requirements of the Contract Documents.

**1.15 ITEM 14 – FURNISH AND PLACE CRUSHED SURFACING MATERIAL, TOP COURSE**

- A. Measurement of Furnish and Place Crushed Surfacing Material, Top Course, shall be by the number of tons placed in the trench and in conformance with the plans, based on truck scale ticket weights.
- B. Payment for Furnish and Place Crushed Surfacing Material, Top Course shall be by the unit price per ton named in the Proposal, which price shall constitute full payment for all tools, equipment, labor, and materials required to complete this work as specified herein; including but not limited to placing and compacting top course material in accordance with requirements of the Contract Documents.

**1.16 ITEM 15 – FURNISH, PLACE, AND COMPACT HMA CLASS ½ INCH, P.G. 64-22 FOR PERMANENT PATCH**

- A. Measurement of Furnish, Place, and Compact HMA Class ½ Inch, P.G. 64-22 for Permanent Patch shall be by the number of tons placed and compacted based on truck ticket weights.
- B. Payment for Furnish Place, and Compact HMA Class ½ Inch, P.G. 64-22 for Permanent Patch shall be by the unit price per ton named in the Proposal, which price shall constitute full payment for all tools, equipment, labor, and materials required to complete this work as specified herein; including but not limited to furnishing, placing and compacting hot mix asphaltic concrete permanent patch in accordance with requirements of the Contract Documents.
- C. Temporary patch work shall be considered incidental to pipeline installation and other pay items.

**1.17 ITEM 16, 28 & 31 – FURNISH AND INSTALL “ ”-INCH DUCTILE IRON PIPE, CL 50 INCLUDING TRENCH EXCAVATION, BACKFILL AND COMPACTION**

- A. Measurement of Furnish and Install “ ”-inch Ductile Iron Pipe, CL 50 Including Trench Excavation, Backfill and Compaction shall be by the number of linear feet of pipe actually installed as determined by horizontal measurement along the pipe centerline.
- B. Payment for Furnishing and Install “ ”-inch Ductile Iron Pipe, CL 50 Including Trench Excavation, Backfill and Compaction shall be by the unit price per linear foot named in the Proposal, which price shall constitute full payment for all tools, equipment, labor, and materials required to complete this work as specified herein; including but not limited to pipe installation, adapters, foster fitting, end caps or plugs, thrust blocking, joint restraints where shown, wax tape wrap, copper blue tracer wire, excavation of pavement and trench, temporary patching, mailbox protection and/or temporary relocation, removal and disposal of asphalt, disposal of excess soils, dewatering, bedding, backfilling, compaction, ditch and landscape restoration, survey and construction staking in accordance with requirements of the Contract Documents.

**1.18 ITEMS 17-25, & 29 – FURNISH AND INSTALL “ ”-INCH DUCTILE IRON ” ” FITTINGS**

- A. Measurement of Furnish and Install “ ”-inch Ductile Iron “ ” Fittings shall be by the number of each type of fitting actually installed, and not included in other lump sum bid items.
- B. Payment for Furnish and Install “ ”-inch Ductile Iron “ ” Fittings shall be by the unit price per each named in the Proposal, which price shall constitute full payment for all tools, equipment, labor, and materials required to complete this work as specified herein; including but not limited to joint connections, wax tape wrap, joint restraints, copper blue tracer wire, excavation of pavement and trench, mailbox protection and/or temporary relocation, removal and disposal of asphalt, disposal of excess soils, dewatering, bedding, backfilling, compaction, ditch and landscape restoration, survey and construction staking in accordance with requirements of the Contract Documents.

**1.19 ITEM 26, 30 & 32 - FURNISH AND INSTALL “ ”-INCH DUCTILE IRON GATE VALVE WITH VALVE BOX AND COVER**

- A. Measurement of Furnish and Install “ ”-inch Ductile Iron Gate Valve with Valve Box and Cover shall be by the number of valves installed.
- B. Payment for Furnish and Install “ ”-inch Gate Valve with Valve Box and Cover shall be by the unit price per each named in the Proposal, which price shall constitute full compensation for all tools, equipment, labor, and materials required to complete this work as specified herein; including but not limited to providing and installing gate valves, valve boxes, covers, extension stems as needed, gaskets, bolt kits, thrust blocking, and copper blue tracer wire, joint connections and restraints, anti-corrosion wrap, excavation of pavement and trench, mailbox protection and/or temporary relocation, removal and disposal of asphalt, disposal of excess soils, dewatering, bedding, backfilling, compaction, ditch and landscape restoration, survey and construction staking in accordance with requirements of the Contract Documents.

**1.20 ITEM 27 - FURNISH AND INSTALL 8”X2” BLIND FLANGE ASSEMBLY WITH 2-INCH DUCTILE IRON GATE VALVE AT STATION 70+20 (MAGNOLIA AVE)**

- A. No measurement of Furnish and Install 8”x2” Blind Flange Assembly with 2-inch Ductile Iron Gate Valve at Station 70+20 (Magnolia Ave) shall be made.
- B. Payment for Furnish and Install 8”x2” Blind Flange Assembly with 2-inch Ductile Iron Gate Valve at Station 70+20 (Magnolia Ave) shall be by the lump sum price named in the Proposal, which price shall constitute full compensation for all tools, equipment, labor, and materials required to complete this work

as specified herein; including but not limited to providing and installing gate valves, valve boxes, supply and installation of 8-inch by 2-inch blind flange, 2-inch brass nipple, 2-inch gate valve, 2-inch pak joint, 2-inch stiffener, covers, extension stems as needed, gaskets, bolt kits, thrust blocking, and copper blue tracer wire, joint connections, anti-corrosion wrap, excavation of pavement and trench, mailbox protection and/or temporary relocation, removal and disposal of asphalt, disposal of excess soils, dewatering, bedding, backfilling, compaction, ditch and landscape restoration, survey and construction staking in accordance with requirements of the Contract Documents.

**1.21 ITEMS 33 – FURNISH AND INTALL 2-INCH REHAU MUNICIPEX**

- A. Measurement of Furnish and Install 2-Inch Rehau Municipex shall be by the linear foot of Rehau pipe installed as determined by horizontal measurement along the pipe centerline.
- B. Payment for Furnish and Install 2-Inch Rehau Municipex shall be made at the unit price per foot named in the Proposal, which payment shall be considered full compensation for all tools, labor, equipment, materials, and incidentals required to complete this work as specified herein; including but not limited to pipe installation, joint connections, copper blue tracer wire, excavation of pavement and trench, temporary patching, mailbox protection and/or temporary relocation, removal and disposal of asphalt, disposal of excess soils, dewatering, bedding, backfilling, compaction, ditch and landscape restoration, survey and construction staking in accordance with the plans and requirements of the Contract Documents.
- C. Asphalt and Crushed Surfacing Top Course will be paid as separate bid items, all other work to complete this work is considered incidental to this bid item.

**1.22 ITEM 34 – FURNISH AND INSTALL FIRE HYDRANT ASSEMBLY**

- A. Measurement of Furnish and Install Fire Hydrant Assembly shall be by the number of fire hydrant assemblies installed.
- B. Payment for Furnish and Install Fire Hydrant Assembly shall be by the unit price per each named in the Proposal, which price shall constitute full payment for all tools, equipment, labor, materials required to complete this work as specified herein: including but not limited to excavation, backfill, thrust blocks, foundations, concrete collar, wax tape wrap, culvert extensions, culvert placement, connections including bolt kits, backer rings, hydrant valve, and joint restraints in accordance with requirements of the Contract Documents.
- C. Mainline valves and flange adapters will be paid as separate unit of work.

**1.23 ITEM 35 – FURNISH AND INSTALL CONCRETE BLOCK WALL**

- A. Measurement of Furnish and Install Concrete Block Wall shall be by the number of square feet of concrete block wall installed.
- B. Payment for Furnish and Install Concrete Block Wall shall be by the unit price per square foot named in the Proposal, which price shall constitute full payment for all tools, equipment, labor, materials required to complete this work as specified herein: including but not limited to excavation, backfill, thrust blocks, foundations, concrete collar, wax tape wrap, culvert extensions, culvert placement, cornerstone F100 block units with caps, fill material, connections including bolt kits, backer rings, hydrant valve, and joint restraints in accordance with requirements of the Contract Documents.
- C. Mainline valves and flange adapters will be paid as separate unit of work.

**1.24 ITEM 36 & 37 – FURNISH AND INSTALL “\_\_”-INCH FLUSHING ASSEMBLY**

- A. Measurement of Furnish and Install “\_\_”-inch Flushing Assembly shall be by the number of each complete flushing assemblies furnished and installed.
- B. Payment for Furnish and Install “\_\_”-inch Flushing Assembly shall be by the unit price per each named in the Proposal which price shall constitute full payment for all tools, equipment, labor, and materials required to complete this work as specified herein: including but not limited to corporation stop, piping and fittings, wax tape wrap, flushing assembly with box, appurtenances, restoration of all landscape, and culvert restorations in accordance with requirements of the Contract Documents.

**1.25 ITEM 38 – FURNISH AND INSTALL 1-INCH COMBINATION AIR VAC ASSEMBLY**

- A. Measurement of Furnish and Install 1-inch Combination Air Vac Assembly shall be by the number of complete assemblies furnished and installed.
- B. Payment for Furnish and Install 1-inch Combination Air Vac Assembly shall be by the unit price per each named in the Proposal, which price shall constitute full payment for all tools, equipment, labor, materials required to complete this work as specified herein: including but not limited to corporation stop, piping and fittings, wax tape wrap, combination air release air/vacuum valve with concrete box, appurtenances, restoration of all landscape, and culvert restorations in accordance with requirements of the Contract Documents.

**1.26 ITEMS 39 & 40 – REPLACE “\_\_”-INCH WATER SERVICE “\_\_”- REHAU MUNICIPEX BY “\_\_” METHODS**

- A. Measurement of Replace “\_\_”-Inch Water Service “\_\_”- REHAU Municipex by “\_\_” Methods shall be by the number of water services replaced or established.
- B. Payment for Replace “\_\_”-Inch Water Service “\_\_”-REHAU Municipex by “\_\_” Methods shall be by the unit price per each named in the Proposal, which payment shall be constitute full payment for all tools, equipment, labor, and materials required to complete this work as specified herein; including but not limited to supply and installation of saddle to the mainline pipe, service corporation, wax tape wrap, REHAU Municipex service line, excavation of trench and asphalt, exposing crossing utilities for moling purposes, backfill, compaction, road restoration, ditch and landscape restoration, culvert restoration, testing, and flushing in accordance with requirements of the Contract Documents.
- C. Asphalt patching and Crushed Surfacing Top Course shall be paid as separate units of work.

**1.27 ITEM 41 - WATERLINE FLUSHING, PRESSURE TESTING, DISINFECTION AND BACTERIA TESTING**

- A. No measurement of Waterline Flushing, Pressure Testing, Disinfection and Bacteria Testing shall be made.
- B. Payment for Waterline Flushing, Pressure Testing, Disinfection and Bacteria Testing shall be by the lump sum price named in the Proposal, which price shall constitute full payment for all tools equipment, labor, and materials required to complete this work as specified herein; including but not limited to waterline pressure testing, flushing and disinfection and bacteria testing, including temporary blocking, temporary flushing assemblies, connections, sample ports, and other appurtenant work, in accordance with the requirements of the Contract Documents.



**1.28 ITEMS 42-63 – CONNECTION WORK AT STA “\_\_+\_\_”**

- A. No measurement of Connection Work at STA “\_\_+\_\_” shall be made.
- B. Payment for Connection Work at STA “\_\_+\_\_” shall be by the lump sum price named in the Proposal, which payment shall constitute full payment for all tools, equipment, labor, and materials required to complete this work as specified herein; including but not limited to excavation, shoring, backfill, thrust blocking, removal and disposal of asphalt, disposal of excess soils, road and shoulder restoration, dewatering for District crew to make final connection to existing pipe lines, ditch and landscape restoration, survey and construction staking in accordance with the requirements of the Contract Documents. No additional measurement will be made for additional contractor tie-ins to facilitate means and methods.
- C. Asphalt patching and Crushed Surfacing Top Course shall be paid as separate units of work.

**PART 2 PRODUCTS (NOT USED)**

**PART 3 EXECUTION (NOT USED)**

**END OF SECTION**

**SECTION - 01060  
REGULATORY REQUIREMENTS**

**PART 1 GENERAL**

**1.1 DESCRIPTION**

- A. This section describes the Contract applicable permits and easements. As shown in the vicinity map on the Contract Plans, work will occur within the County of Skagit, State of Washington.

**1.2 PERMITS**

- A. Keep fully informed of all local ordinances, as well as state and federal laws, which in any manner affect the work herein specified. At all times comply with said ordinances, laws, and regulations, and protect and indemnify the OWNER and its officers and agents against any claim or liability arising from or based on the violation of such laws, ordinances, or regulations. Secure and pay for all permits, licenses, and inspection fees necessary for prosecution and completion of the work unless otherwise specified.
- B. Permits:
1. OWNER will provide and pay all fees for the permits shown in Attachment A.
  2. Comply with all conditions attached to applicable federal, state, and local permits
  3. Obtain all other permits, not provided by the OWNER
  4. Copies of the issued permits are included in Appendix B
- C. Terms and conditions of the permits obtained by the OWNER prior to bid submittal are included in Appendix B. Comply with all applicable terms and conditions contained in such permits.
- D. Anticipated terms and conditions of permits not secured prior to bid submittal which are to be obtained by the OWNER are included in the specifications.

**1.3 EASEMENTS**

- A. The OWNER has or will obtain easements for portions of the work as required. Easements provide for the use of private property for construction purposes or for access during construction to the extent indicated in the easements. It shall be the CONTRACTOR's responsibility to:
1. Determine the limitations in the easement obtained in every case and to abide by all requirements and provisions of the easement.
  2. Confine construction operations to within the easement limits or street right-of-way limits or make special arrangements with the property owner and appropriate public agency for the additional area required.
  3. Pay for any property use outside the prescribed limits and easements provided for in the Contract Documents.
  4. Repair to an equal to or better condition any property damaged either inside or outside the limits of the easements.
  5. Remove, protect, and reinstall all fences, mailboxes, paving, utilities or other items encountered on public or private property.
  6. If the CONTRACTOR makes "special arrangements" with property owner, then the CONTRACTOR shall inform the OWNER of these arrangements and provide written documents.
  7. CONTRACTOR may negotiate with the adjacent property owner if additional easements are required.
- B. CONTRACTOR shall comply with all applicable terms and conditions contained in such easements and additional easements that the CONTRACTOR may acquire.

**1.4 PERMITS AND EASEMENTS OBTAINED AFTER BID SUBMITTAL**

- A. If, after the bid submittal date, the OWNER obtains any permits or easements which require changes to the work hereunder and thereby cause an increase or decrease in the cost of, or the time required for, the performance of the work, submit information sufficient for the OWNER to determine the extent of the effects on the cost and/or schedule. If the OWNER agrees the cost and/or schedule will be affected by such changes, such effects will be handled in accordance with the General Conditions. The OWNER will provide CONTRACTOR with a copy of any such permits or easements. The CONTRACTOR shall comply with all applicable terms and conditions contained in such permits or easements.

**1.5 EASEMENTS AND AGREEMENTS TO BE OBTAINED BY THE CONTRACTOR**

- A. Obtain all other easements, permits and agreements required to perform the work. Prepare and submit to the proper authority all information required for the issuance of such easements, permits and agreements and pay all costs thereof, including agency inspections unless specifically provided otherwise in these Contract Documents. Submit a copy of each such easement, permit and agreement to the OWNER.

**1.6 POSTING PERMITS AND EASEMENTS**

- A. Post permits at the site of the work if required.

**1.7 RESTORATION OF PROPERTY**

- A. Comply with all property restoration requirements contained in permits, easements and agreements to complete the work.
- B. Restoration of road shoulders within the right of way, driveways, and private property and landscaping outside the neat lines of work damaged by the Contractor through the course of the work or by accident shall be repaired to same at no cost to the Owner unless specifically called out as separate units of work.
- C. Whenever any work is performed on property where an easement, permit or agreement has been obtained by the CONTRACTOR, submit to the OWNER, before final payment under Section 01700 – Project Closeout, a written release from the property owner or proper authority acting for the owner, of each property affected, stating that the restoration of structures and surfaces has been completed to the satisfaction of the owner and that the owner has no claims for damages on account of such restoration. Use the release form provided by the OWNER. If, in the opinion of the OWNER, the release is unreasonably withheld by the property owner, the OWNER may, in its sole discretion, accept the portion of the work involved and cause final payment to be made.

**1.8 HOURS OF WORK**

- A. Comply with Section 01313 - Construction and Schedule Constraints.

**1.9 LICENSES**

- A. The CONTRACTOR is responsible for obtaining all required licenses including all required Business License(s).

**PART 2 PRODUCTS (NOT USED)**

**PART 3 EXECUTION (NOT USED)**

**END OF SECTION**



*Owner Release Form*

To: \_\_\_\_\_  
\_\_\_\_\_  
\_\_\_\_\_

We (I), the undersigned, hereby acknowledge that \_\_\_\_\_  
contractor, has satisfactorily restored the surface of the property owned by us (me) upon, or  
under which said contractor has performed work pursuant to contract with the \_\_\_\_\_  
\_\_\_\_\_  
\_\_\_\_\_

\_\_\_\_\_  
(Owner)

\_\_\_\_\_  
(Owner)

Address: \_\_\_\_\_  
\_\_\_\_\_

Date: \_\_\_\_\_ 2024

# **Attachment A**

## **PUD No. 1 of Skagit County Permits/Approvals**

## Attachment A

<b>West Mount Vernon Pipeline Replacement Project Permits/Approvals</b>					
<b>Agency/Jurisdiction</b>	<b>Permit Name</b>	<b>Submitted</b>	<b>Permit #</b>	<b>Status<sup>(1)</sup></b>	<b>Issued Date <sup>(2)</sup></b>
City of Burlington	Right of Way Permit		ROW 24-0036	Approved	7/15/24
			ROW 24-0037	Approved	7/15/24
			ROW 24-0038	Approved	7/15/24
			ROW 24-0039	Approved	7/15/24

Notes:

(1) Issued permits/approvals are included in Appendix B. Remaining permits/approvals will be provided when received.

(2) Date is issuance date or issuance date anticipated for permit. Work cannot begin within the jurisdictions or right-of-ways until after the date shown.

**SECTION - 01070**  
**ABBREVIATIONS OF INSTITUTIONS**

**PART 1 GENERAL**

**1.1 GENERAL**

- A. Wherever in these Specifications references are made to the standards, specifications, or other published data of the various international, national, regional, or local organizations, such organizations may be referred to by their acronym or abbreviation only. As a guide to the user of these Specifications, the following acronyms or abbreviations which may appear in these Specifications shall have the meanings indicated herein.

**1.2 ABBREVIATIONS**

AAMA	Architectural Aluminum Manufacturer's Association
ASQC	American Society for Quality Control
BBC	Basic Building Code, Building Officials and Code Administrators International
BNSF	Burlington Northern Santa Fe Railroad
BPA	Bonneville Power Administration
EIA	Electronic Industries Association
ETL	Electrical Test Laboratories
IAPMO	International Association of Plumbing and Mechanical Officials
ICBO	International Conference of Building Officials
ISA	Instrument Society of America
ISO	International Organization for Standardization
MSS	Manufacturers Standardization Society
NAAMM	National Association of Architectural Metal Manufacturer's
NACE	National Association of Corrosion Engineers
NBS	National Bureau of Standards
NCCLS	National Committee for Clinical Laboratory Standards
PUD	Public Utility District No. 1
RWMA	Resistance Welder Manufacturer's Association
SAMA	Scientific Apparatus Makers Association
SMA	Screen Manufacturers Association
SPFA	Steel Plate Fabricators Association
SPR	Simplified Practice Recommendation
SSPWC	Standard Specifications for Public Works Construction
UBC	Uniform Building Code
UPRR	Union Pacific Railroad
WCRSI	Western Concrete Reinforcing Steel Institute

Other acronyms or abbreviations may appear and shall be determined by the context in which they are used.

**PART 2 PRODUCTS (NOT USED)**

**PART 3 EXECUTION (NOT USED)**

**END OF SECTION**

**SECTION - 01090**  
**REFERENCE STANDARDS**

**PART 1 GENERAL**

**1.1 GENERAL**

- A. **Titles of Sections and Paragraphs:** Captions accompanying specification sections and paragraphs are for convenience of reference only, and do not form a part of the Specifications.
- B. **Applicable Publications:** Whenever in these Specifications references are made to published specifications, codes, standards, or other requirements, it shall be understood that wherever no date is specified, only the latest specifications, standards, or requirements of the respective issuing agencies which have been published as of the date that the WORK is advertised for bids, shall apply; except to the extent that said standards or requirements may be in conflict with applicable laws, ordinances, or governing codes. No requirements set forth herein or shown on the Drawings shall be waived because of any provision of, or omission from, said standards or requirements.
- C. **Specialists, Assignments:** In certain instances, specification text requires (or implies) that specific work is to be assigned to specialists or expert entities, who must be engaged for the performance of that work. Such assignments shall be recognized as special requirements over which the CONTRACTOR has no choice or option. These requirements shall not be interpreted so as to conflict with the enforcement of building codes and similar regulations governing the WORK; also they are not intended to interfere with local union jurisdiction settlements and similar conventions. Such assignments are intended to establish which party or entity involved in a specific unit of work is recognized as "expert" for the indicated construction processes or operations. Nevertheless, the final responsibility for fulfillment of the entire set of contract requirements remains with the CONTRACTOR.

**1.2 REFERENCE SPECIFICATIONS, CODES, AND STANDARDS**

- A. Without limiting the generality of other requirements of the Specifications, all work specified herein shall conform to or exceed the requirements of applicable codes and the applicable requirements of the following documents.
- B. References herein to "Building Code" or "Uniform Building Code" shall mean Uniform Building Code of the International Conference of Building Officials (ICBO). Similarly, references to "Mechanical Code" or "Uniform Mechanical Code," "Plumbing Code" or "Uniform Plumbing Code," "Fire Code" or "Uniform Fire Code," shall mean Uniform Mechanical Code, Uniform Plumbing Code and Uniform Fire Code of the International Conference of the Building Officials (ICBO). "Electric Code" or "National Electric Code (NEC)" shall mean the National Electric Code of the National Fire Protection Association (NFPA). The latest edition of the codes as approved by the Municipal Code and used by the local agency as of the date that the WORK is advertised for bids, as adopted by the agency having jurisdiction, shall apply to the WORK herein, including all addenda, modifications, amendments, or other lawful changes thereto.
- C. In case of conflict between codes, reference standards, drawings and the other Contract Documents, the most stringent requirements shall govern. All conflicts shall be brought to the attention of the OWNER for clarification and directions prior to ordering or providing any materials or furnishing labor. The CONTRACTOR shall bid for the most stringent requirements.
- D. The CONTRACTOR shall construct the WORK specified herein in accordance with the requirements of the Contract Documents and the referenced portions of those referenced codes, standards, and specifications listed herein.



- E. **Applicable Standard Specifications:** References in the Contract Documents to "Standard Specifications" shall mean the Standard Specifications for Road, Bridge, and Municipal Construction of the Washington State Department of Transportation and Washington State Chapter of American Public Works Association, 2024 edition, which applicable parts are incorporated herein and made a part of these Documents by specific reference thereto. If requirements contained in the Standard Specifications are modified by or are in conflict with supplemental information in these Contract Documents, the requirements of these Contract Documents shall prevail.
- F. References herein to "OSHA Regulations for Construction" shall mean **Title 29, Part 1926, Construction Safety and Health Regulations**, Code of Federal Regulations (OSHA), including all changes and amendments thereto.
- G. References herein to "OSHA Standards" shall mean **Title 29, Part 1910, Occupational Safety and Health Standards**, Code of Federal Regulations (OSHA), including all changes and amendments thereto.
- H. References herein to "WISHA Standards" shall mean **Chapter 296 - 24 WAC, General Safety and Health Standard**, State of Washington, Division of Industrial Safety and Health, (WISHA) including all changes and amendments thereto.
- I. References herein to "WISHA Standards for Construction" shall mean **Chapter 296 - 155 WAC, Safety Standards for Construction Work**, State of Washington, Division of Industrial Safety and Health, (WISHA) including all changes and amendments thereto.

### 1.3 REGULATIONS RELATED TO HAZARDOUS MATERIALS

- A. The CONTRACTOR is responsible that all work included in the Contract Documents, regardless if shown or not, shall comply with all EPA, OSHA, RCRA, NFPA, and any other Federal, State, and Local Regulations governing the storage and conveyance of hazardous materials, including petroleum products.

### PART 2 PRODUCTS (NOT USED)

### PART 3 EXECUTION (NOT USED)

END OF SECTION

**SECTION - 01300  
CONTRACTOR SUBMITTALS**

**PART 1 GENERAL**

**1.1 GENERAL**

- A. Wherever submittals are required hereunder, all such submittals by the CONTRACTOR shall be submitted to the OWNER.

**1.2 DEFINITIONS**

- A. Shop Drawings:
1. See General Conditions.
  2. Product data and samples are Shop Drawing information.
  3. Manufacturer Certification
- B. Miscellaneous Submittals:
1. Submittals other than Shop Drawings and O&M Manuals.
  2. Representative types of miscellaneous submittal items include but are not limited to:
    - a. Construction schedule
    - b. Shutdown Plan and Schedule of work for connection to District's 6-inch transmission lines
    - c. Cost breakdown (Schedule of Values)
    - d. Construction Stormwater Pollution Prevention Plan (SWPPP)
    - e. Spill Prevention Control and Countermeasure Plan
    - f. Accident Prevention Plan and Site Health and Site Specific Safety Plan
    - g. Traffic Control Plan
    - h. Dewatering Plan
    - i. Concrete, soil compaction, and pressure test reports.
    - j. Installed equipment and systems performance test reports
    - k. Manufacturer's installation certification letters
    - l. Instrumentation and control commissioning reports
    - m. Warranties
    - n. Construction photographs
    - o. Survey data
    - p. Disinfection and flushing plan

**1.3 PRECONSTRUCTION CONFERENCE SUBMITTALS**

- A. At the preconstruction conference referred to in Section 01010, Summary of Work, which shall be held within ten (10) days of Notice to Proceed, the CONTRACTOR shall submit the following items to the OWNER for review:
1. A preliminary schedule of Shop Drawings and Samples.
  2. A list of all submittals that will be prepared and a schedule for submission to the OWNER.
  3. A list of all permits and licenses the CONTRACTOR is obtaining per the requirements of these Contract Documents indicating the agency required to grant the permit, the expected date of submittal for the permit, and required date for receipt of the permit.
  4. A 30-day plan of operation in accordance with Section 01311 - Scheduling and Reporting.
  5. A Progress Schedule in accordance with Section 01311 - Scheduling and Reporting, which identifies critical activities to meet the project milestones.
  6. Erosion Control Plan for areas outside of the right-of-way and any alternative Traffic Control Plan.

## 1.4 PREPARATION OF SUBMITTALS

### A. General:

1. All submittals and all pages of all copies of a submittal shall be completely legible.
2. Submittals which, in the Engineer's sole opinion, are illegible will be returned without review.

### B. Shop Drawings:

1. Wherever called for in the Contract Documents, or where required by the OWNER, the CONTRACTOR shall furnish to the OWNER for review, three copies, plus one reproducible copy, (When feasible an electronic copy may be substituted), of each shop drawing submittal. The term "Shop Drawings" as used herein shall be understood to include detailed design calculations, shop drawings, fabrication, and installation drawings, erection drawings, lists, graphs, catalog sheets, data sheets, and similar items. Whenever the CONTRACTOR is required to submit design calculations as part of a submittal, such calculations shall bear the signature and seal of an engineer registered in the appropriate branch in Washington State, unless otherwise directed.
2. All Shop Drawing submittals shall be accompanied by the OWNER's standard submittal transmittal form which is appended at the end of this section or the CONTRACTOR's standard transmittal form approved by the OWNER. Any submittal not accompanied by such a form, or where all applicable items on the form are not completed, will be returned for resubmittal.
3. Except as may otherwise be indicated herein, the OWNER will return prints of each submittal to the CONTRACTOR with its comments noted thereon, within 14 calendar days following their receipt by the OWNER. It is considered reasonable that the CONTRACTOR shall make a complete and acceptable submittal to the OWNER by the second submission of a submittal item. The OWNER reserves the right to withhold money due to the CONTRACTOR to cover additional costs of the submittal review beyond the second submittal. The OWNER'S maximum review period for each submittal, including all resubmittals, will be 14 days per submittal. In other words, for a submittal that requires two resubmittals before it is complete, the maximum review period for that submittal could be 28 days.
4. The OWNER's review of CONTRACTOR shop drawings submittals shall not relieve the CONTRACTOR of the entire responsibility for the correctness of details and dimensions. The CONTRACTOR shall assume all responsibility and risk for any misfits due to any errors in CONTRACTOR submittals. The CONTRACTOR shall be responsible for the dimensions and the design of adequate connections and details.
5. Numbering letter of transmittal:
  - a. Assign submittal numbers beginning with "001" and increasing sequentially with each additional transmittal.
6. Describing transmittal contents:
  - a. Provide listing of each component or item in submittal capable of receiving an independent review action.
  - b. Identify for each item:
    - 1) Manufacturer and Manufacturer's Drawing or data number.
    - 2) Contract Drawing Section or detail number if applicable.
    - 3) Specification Article/Paragraph number if applicable.
    - 4) Unique page numbers for each page of each separate item.
  - c. When submitting "or-equal" items that are not the products of named manufacturers, include the words "or-equal" in the item description.
7. Resubmittals:
  - a. Number with original root number and a suffix letter starting with "A" on a (new) duplicate transmittal form.
  - b. Do not increase the scope of any prior transmittal.
  - c. Account for all components of prior transmittal.
    - 1) If items in prior transmittal received "A" or "B" Action code, list them and indicate "A" or "B" as appropriate.
      - a) Do not include submittal information for items listed with prior "A" or "B" Action in resubmittal.

- 2) Indicate "Outstanding-To Be Resubmitted At a Later Date" for any prior "C" or "D" Action item not included in resubmittal.
  - a) Obtain Engineer's approval to exclude items.
8. Contractor shall not use red color for marks on transmittals.
  - a. Duplicate all marks on all copies transmitted, and ensure marks are photocopy reproducible.
  - b. Outline Contractor marks on reproducible transparencies with a rectangular box.
9. Transmittal contents:
  - a. Coordinate and identify Shop Drawing contents so that all items can be easily verified by the Engineer.
  - b. Identify equipment or material use, Drawing detail reference, weight, and other Project specific information.
  - c. Provide sufficient information together with technical cuts and technical data to allow an evaluation to be made to determine that the item submitted is in compliance with the Contract Documents.
  - d. Submit items such as equipment brochures, cuts of fixtures, product data sheets or catalog sheets on 8-1/2 x 11-inch pages.
    - 1) Indicate exact item or model and all options proposed.
  - e. When a Shop Drawing submittal is called for in any Specification Section, include as appropriate, scaled details, sizes, dimensions, performance characteristics, capacities, test data, anchoring details, installation instructions, storage and handling instructions, color charts, layout Drawings, rough-in diagrams, wiring diagrams, controls, weights and other pertinent data in addition to information specifically stipulated in the Specification Section.
    - 1) Arrange data and performance information in format similar to that provided in Contract Documents.
    - 2) Provide, at minimum, the detail specified in the Contract Documents.
  - f. If proposed equipment or materials deviate from the Contract Drawings or Specifications in any way, clearly note the deviation and justify the said deviation in detail in a separate letter immediately following transmittal sheet.

## 1.5 ENGINEER'S REVIEW ACTION

- A. Shop Drawings and Samples:
  1. Items within transmittals will be reviewed for overall design intent and will receive one of the following actions:
    - a. A - FURNISH AS SUBMITTED.
    - b. B - FURNISH AS NOTED.
    - c. C - REVISE AND RESUBMIT.
    - d. D - REJECTED.
    - e. E - ENGINEER'S REVIEW NOT REQUIRED.
  2. Submittals received will be initially reviewed to ascertain inclusion of Contractor's approval stamp.
    - a. Submittals not stamped by the Contractor or stamped with a stamp containing language other than that specified herein will not be reviewed for technical content and will be returned without any action.
  3. In relying on the representation on the Contractor's review and approval stamp, Owner and Engineer reserve the right to review and process poorly organized and poorly described submittals as follows:
    - a. Submittals transmitted with a description identifying a single item and found to contain multiple independent items:
      - 1) Review and approval will be limited to the single item described on the transmittal letter.
      - 2) Other items identified in the submittal will:
        - a) Not be logged as received by the Engineer.
        - b) Be removed from the submittal package and returned without review and comment to the Contractor for coordination, description and stamping.
        - c) Be submitted by the Contractor as a new series number, not as a re-submittal number.
    - b. Engineer, at Engineer's discretion, may revise the transmittal letter item list and descriptions, and conduct review.

- 1) Unless Contractor notifies Engineer in writing that the Engineer's revision of the transmittal letter item list and descriptions was in error, Contractor's review and approval stamp will be deemed to have applied to the entire contents of the submittal package.
4. Submittals returned with Action "A" or "B" are considered ready for fabrication and installation.
  - a. Three copies of said submittal will be returned to the Contractor.
  - b. If for any reason a submittal that has an "A" or "B" Action is resubmitted, it must be accompanied by a letter defining the changes that have been made and the reason for the resubmittal.
  - c. Destroy or conspicuously mark "SUPERSEDED" all documents having previously received "A" or "B" Action that are superseded by a resubmittal.
5. Submittals with Action "A" or "B" combined with Action "C" (Revise and Resubmit) or "D" (Rejected) will be individually analyzed giving consideration as follows:
  - a. The portion of the submittal given "C" or "D" will not be distributed (unless previously agreed to otherwise at the Preconstruction Conference).
    - 1) One (1) copy or the one (1) transparency of the "C" or "D" Drawings will be marked up and returned to the Contractor.
      - a) Correct and resubmit items so marked.
    - b. Items marked "A" or "B" will be fully distributed.
    - c. If a portion of the items or system proposed is acceptable, however, the major part of the individual Drawings or documents are incomplete or require revision, the entire submittal may be given "C" or "D" Action.
      - 1) This is at the sole discretion of the Engineer.
      - 2) In this case, some Drawings may contain relatively few or no comments or the statement, "Resubmit to maintain a complete package."
      - 3) Distribution to the Owner and field will not be made (unless previously agreed to otherwise).
  6. Failure to include any specific information specified under the submittal paragraphs of the Specifications will result in the submittal being returned to the Contractor with "C" or "D" Action.
  7. Calculations required in individual Specification Sections will be received for information purposes only, as evidence calculations have been performed by individuals meeting specified qualifications, and will be returned stamped "E. Engineer's Review Not Required" to acknowledge receipt.
  8. All costs associated with the Engineer's review of any Shop Drawing resubmitted more than once shall be borne by the Contractor with said costs being deducted from the Contract Price.
  9. Transmittals of submittals which the Engineer considers as "Not Required" submittal information, which is supplemental to but not essential to prior submitted information, or items of information in a transmittal which have been reviewed and received "A" or "B" Action in a prior submittal, will be returned with Action "E. Engineer's Review Not Required."
  10. Samples may be retained for comparison purposes.
    - a. Remove samples when directed.
    - b. Include in bid all costs of furnishing and removing samples.
  11. Approved samples submitted or constructed, constitute criteria for judging completed work.
    - a. Finished work or items not equal to samples will be rejected.

## 1.6 SAMPLES

- A. Whenever in the Specifications samples are required, the CONTRACTOR shall submit not less than three samples of each item or material to the OWNER for acceptance at no additional cost to the OWNER.
- B. Samples, as required herein, shall be submitted for acceptance a minimum of 21 days prior to ordering such material for delivery to the jobsite, and shall be submitted in an orderly sequence so that dependent materials or equipment can be assembled and reviewed without causing delays in the WORK.
- C. All samples shall be individually and indelibly labeled or tagged, indicating thereon all specified physical characteristics and Manufacturer's name for identification and submitted to the OWNER for acceptance. Upon receiving acceptance of the OWNER, one set of the samples will be stamped and dated by the

OWNER and returned to the CONTRACTOR, and one set of samples will be retained by the OWNER, and one set of samples shall remain at the job site until completion of the WORK.

- D. Unless indicated otherwise, all colors and textures of specified items presented in sample submittals shall be from the manufacturer's standard colors and standard materials, products, or equipment lines. If the samples represent non-standard colors, materials, products, or equipment lines and their selection will require an increase in contract time or price, the CONTRACTOR will clearly indicate same on the transmittal page of the submittal.

#### **1.7 CONTRACTOR'S SCHEDULE SUBMITTAL**

- A. See Section 01311 for CONTRACTOR's schedule submittal requirements.

#### **PART 2 PRODUCTS (NOT USED)**

#### **PART 3 EXECUTION (NOT USED)**

**END OF SECTION**



# Contractor's Submittal Transmittal Form

For all contractor submittals, including shop drawings, samples calculation, data, or other

Date	Transmittal No.
------	-----------------

**Project Name: North Burlington Pipeline Replacement Project**

Owner: Public Utility District No. 1 of Skagit County	Contractor:
---	-------------

Attention: Michelle Peters	Attention:
----------------------------	------------

Address: 1415 Freeway Drive Mount Vernon, WA 98273	Address:
--	----------

<b>Action Legend:</b> A – Furnish As Submitted B – Furnish As Noted C – Revise and Resubmit D – Rejected E – Engineer’s Review Not Required	<b>This is:</b> Check one <div style="display: flex; justify-content: space-between; align-items: flex-start;"> <div style="width: 40%;"><input type="checkbox"/></div> <div style="width: 60%;">an original submittal</div> </div> <div style="display: flex; justify-content: space-between; align-items: flex-start; margin-top: 10px;"> <div style="width: 40%;"><input type="checkbox"/></div> <div style="width: 60%;">a 2nd submittal</div> </div> <div style="display: flex; justify-content: space-between; align-items: flex-start; margin-top: 10px;"> <div style="width: 40%;"><input type="checkbox"/></div> <div style="width: 60%;">a ____ submittal</div> </div>
--	---

Item No.	Description	Spec Section or Drawing No.	Action Taken

District Reviewer: \_\_\_\_\_

Contractor to complete either (a) or (b), following:

(a) We have verified that the materials or equipment contained in this submittal meets all the requirements specified or shown (no exceptions)

(b) We have verified that the material or equipment contained in this submittal meets all the requirements specified or shown, except for the following deviations (List Deviations):

--	--

Contractor's Authorized Representative \_\_\_\_\_

## SECTION - 01311

### SCHEDULING AND REPORTING

#### PART 1 GENERAL

##### 1.1 GENERAL

- A. The scheduling of the WORK under the Contract shall be performed by the CONTRACTOR in accordance with the requirements of this section. Where submittals are required hereunder, the CONTRACTOR shall submit four copies of each submittal item.
- B. Scheduling terms and practices shall conform to the standards established in "Construction Planning and Scheduling, Second Edition", published by the Associated General Contractors of America. Except for weekly look-ahead schedules, all schedules shall meet these general requirements and provide the following information:
  - 1. Include all activities necessary to physically complete the project.
  - 2. Show the planned order of WORK activities in a logical sequence.
  - 3. Show durations of WORK activities in working days.
  - 4. Show activity durations that are reasonable for the intended WORK.
  - 5. Show activity durations in sufficient detail to evaluate progress of individual activities on a daily basis.
  - 6. Show the completion of all work within the authorized contract time.

##### 1.2 SCHEDULE SUBMITTALS

- A. The CONTRACTOR shall submit two schedule documents at the Preconstruction Conference. The schedule documents shall reflect the Construction and Schedule Constraints identified in Section 01313.
  - 1. **Progress Schedule:** The Progress Schedule may be a critical path method (CPM) schedule, bar chart, or other standard schedule format. Regardless of which format is used, the schedule shall identify the critical path. The Progress Schedule shall indicate the relationships and time frames in which the various components of the WORK will be made substantially complete and placed into service in order to meet the project milestones. For the main pipeline work, sufficient detail shall be included for the identification of subdivisions of major components into such activities as (1) shop drawing submittals, (2) pipe fabrication and delivery, (3) installation of erosion/sedimentation control measures, (4) Traffic Control Plan signage procurement and installation, (5) trench excavation and backfill with pipe laying and erosion/sedimentation control, (6) surface restoration including pavement and revegetation, (7) pipeline testing and disinfection, startup of pipeline and related facilities, (8) permit and other scheduling constraints, and (9) other important work for each major facility within the overall project scope.
  - 2. **3-Week Bar Chart:** Throughout the duration of the project the Contractor shall submit weekly bar charts of operation showing the work that has been completed over the course of the previous work week and the plan of operation for the next two weeks. The bar chart so prepared and submitted shall show the accomplishments of the Contractor and for comparison to the Progress Schedule.
- B. If requested by the OWNER, the OWNER and the CONTRACTOR shall meet to review and discuss the 3-Week Bar Chart and Progress Schedule and within 5 days after they have been submitted to the OWNER. The OWNER's review and comment on the schedules shall be limited to Contract conformance (with the construction and schedule constraints as stated in Section 01313). The CONTRACTOR shall make corrections to the schedules necessary to comply with the Contract requirements and shall adjust the schedules to incorporate any missing information requested by the OWNER.
- C. Within 14 days of receipt of comments, the CONTRACTOR shall have revised the original Progress Schedule submittal to address all review comments from the original schedule review meeting and resubmit revised Progress Schedule for the OWNER'S review. The OWNER, within 14 days from the date that the CONTRACTOR submitted his revised schedule will either (1) accept the schedule as submitted, or (2) advise the CONTRACTOR in writing to revise any part or parts of the schedule which



either do not meet the Contract requirements or are unsatisfactory for the OWNER to monitor the project's progress and status or evaluate monthly payment requests by the CONTRACTOR. The OWNER reserves the rights to require that the CONTRACTOR adjust, add to, or clarify any portion of the schedule that may later be insufficient for the monitoring of the WORK or approval of partial payment requests. No additional compensation will be provided for such adjustments or clarifications.

- D. The acceptance of the CONTRACTOR'S schedule by the OWNER will be based solely upon the schedule's compliance with the Contract requirements. By way of the CONTRACTOR assigning activity durations and proposing the sequence of the WORK, the CONTRACTOR agrees to utilize sufficient and necessary management and other resources to perform the work in accordance with the schedule. Upon submittal of a schedule update, the updated schedule shall be considered the "current" project schedule.
  - 1. Submission of the CONTRACTOR's progress schedule to the OWNER shall not relieve the CONTRACTOR of total responsibility for scheduling, sequencing, and pursuing the WORK to comply with the requirements of the Contract Documents, including adverse effects such as delays resulting from ill-timed work.
- E. Following the acceptance of the CONTRACTOR's schedule, the CONTRACTOR shall monitor the progress of the WORK and adjust the schedule at each meeting to reflect actual progress and any changes in planned future activities. Each schedule update submitted must be complete including all information requested in the original schedule submittal. Each update shall continue to show all work activities including those already completed. These completed activities shall accurately reflect the "as built" information by indicating when the work was actually started and completed.
  - 1. Neither the submission nor the updating of the CONTRACTOR's original schedule submittal nor the submission, updating, change or revision of any other report, curve, schedule or narrative submitted to the OWNER by the CONTRACTOR under this Contract, nor the OWNER's review or acceptance of any such report, curve, schedule or narrative shall have the effect of amending or modifying, in any way, the Contract completion date or milestone dates or of modifying or limiting, in any way, the Contractor's obligations under this Contract. Only a signed, fully executed change order can modify these contractual obligations.
- F. The 3-Week Bar Chart will be reviewed with the CONTRACTOR during the weekly construction progress meeting. The goal of these meetings is to enable the CONTRACTOR and the OWNER to initiate appropriate remedial action to minimize any known or foreseen delay in completion of the WORK and to determine the amount of WORK completed since the previous schedule update. The status of the WORK will be determined by the percent completion of each activity shown on the schedule. These meetings are considered a critical component of the overall schedule update submittal and the CONTRACTOR shall have appropriate personnel attend. As a minimum, these meetings shall be attended by the contractor's Project Manager and General Superintendent.

### **1.3 CHANGE ORDERS**

- A. Upon approval of a change order, or upon receipt by the CONTRACTOR of authorization to proceed with additional work, the change shall be reflected in the next submittal of the schedule by the CONTRACTOR.

### **1.4 PROJECT STATUS REPORTING**

- A. The CONTRACTOR shall prepare monthly written narrative reports of the status of the project for submission to the OWNER.
  - 1. Written status reports shall include:
    - a. The status of major project components (Percent Complete, amount of time ahead or behind schedule) and an explanation of how the project will be brought back on schedule if delays have occurred.
    - b. The progress made on critical activities indicated on the Progress Schedule.
    - c. Explanations for any work scheduled but not completed on critical path activities during the previous month.
    - d. Explanations for any schedule changes.
    - e. A list of the critical activities scheduled to be performed in the next month period.
    - f. The status of major material and equipment procurement.

- g. The value of materials and equipment properly stored at the site, but not yet incorporated into the work-in-place.
  - h. Any delays encountered during the reporting period.
2. The CONTRACTOR may include any other information pertinent to the status of the project. The CONTRACTOR shall include additional status information requested by the OWNER.

**PART 2 PRODUCTS (NOT USED)**

**PART 3 EXECUTION (NOT USED)**

**END OF SECTION**

**SECTION - 01313  
CONSTRUCTION AND SCHEDULE CONSTRAINTS**

**PART 1 GENERAL**

**1.1 DESCRIPTION**

- A. This section identifies constraints on the construction schedule imposed by permits, environmental regulation, and other agency requirements. The CONTRACTOR is expected to use this information in preparing construction schedules. The purpose of this section is to ensure adequate planning and performance of the work by the CONTRACTOR in compliance with permits and other regulatory constraints.

**1.2 SUBMITTALS**

- A. Submittals for this section shall be in accordance with Section 01300 and Section 01311 of these Specifications.
- B. Construction schedule shall clearly show restricted portions of the project with respect to time and hours of work.

**1.3 RELATED SECTIONS**

- A. Section 01060 – Regulatory Requirements.
- B. Section 01311 – Scheduling and Reporting.

**1.4 SCHEDULE CONSTRAINTS**

- A. Some permits may have specific restrictions on construction timing, work hours and type of construction activity allowed. The CONTRACTOR shall abide by all restrictions imposed by these permits.
- B. The CONTRACTOR shall prepare a construction schedule, which incorporates the schedule information shown on the drawings and in Table 1 at the end of this section. These constraints have been identified here for the convenience of the CONTRACTOR. However, all schedule constraints identified in permits, regulations, or elsewhere in the Specifications or Drawings shall be incorporated into the CONTRACTOR's schedule, whether included in Table 1 or not.
- C. The CONTRACTOR shall attend meetings with affected property owner to coordinate work activities.

**1.5 PROPERTY CONSTRAINTS**

- A. **Landowner Coordination Meetings:** The CONTRACTOR shall be available for periodic construction coordination meetings with the landowner as the CONTRACTOR proceeds with work along the access road, as this road is the only ingress and egress for the landowner. These meetings will ensure the proper coordination for safe ingress and egress of the property.

**1.6 TRAFFIC CONTROL CONSTRAINTS**

- A. Working hours for the project shall be from Table 1 at end of this section.

**1.7 PIPELINE SHUTDOWN AND CONNECTION WORK CONSTRAINTS**

- A. The interconnection to the existing pipelines will be completed by Skagit PUD crews only. Provide 3 Days Notice to the OWNER prior to requesting Skagit PUD connections to existing water system.
- B. The contractor will be responsible for all excavation, shoring, dewatering, traffic control, concrete thrust blocking, blocking, backfill, compaction, and surface and/or landscape restoration work necessary for Skagit PUD's connection work as indicated on the plans.
- C. Scheduling of Connection Work shall be reflected on the schedule as mile stones.

**PART 2 PRODUCTS (NOT USED)**

**PART 3 EXECUTION (NOT USED)**

<b>TABLE 1</b>		
<b>CONSTRUCTION TIMING CONSTRAINTS SUMMARY</b>		
<b>Location/ Jurisdiction<sup>(1)</sup></b>	<b>Activity</b>	<b>Constraints<sup>(2)</sup></b>
City of Burlington	Construction Hours	<ul style="list-style-type: none"> <li>• 7 AM – 9 PM, Monday through Friday</li> <li>• 8 AM – 9 PM, Saturday and Sunday</li> <li>• To work outside of normal hours, a request must be submitted to the City of Burlington. The City Official will review and issue a written approval (administrative process).</li> </ul>
PUD No. 1 of Skagit County	Connection to Existing Pipeline  Project Phasing  Customers	<ul style="list-style-type: none"> <li>• Provide 3-day Notice prior to start of work</li> <li>• Tie in Notification</li> <li>• Service Connection</li> <li>• Reflect Project Phasing in Order of Operation and on Schedule</li> <li>• Give Customers 24 hours notice that water will be shut off to property in order to make connections to existing mainlines.</li> </ul>
Notes: (1) Per locations noted on drawings. (2) Unless otherwise noted, a time period is when construction can occur. If there is a conflict between permits/approvals, the more restrictive constraint will apply. (3) Attached in Appendix C is a copy of the Archaeological Inadvertent Discovery Plan. In the event of such a discovery the Contractor shall comply with the plan.		

**END OF SECTION**

**SECTION - 01350**  
**SAFE WORKPLACE**

**PART 1 GENERAL**

**1.1 GENERAL**

- A. CONTRACTOR warrants that before starting the job, it will develop and furnish Skagit PUD with a copy of the table of contents from its written Accident Prevention Program (APP) and a complete site-specific Health and Safety Plan (HSP), which identifies anticipated job safety hazards within the scope of its contract and for all phases of its contract and which addresses the specific means it will use to address each hazard. CONTRACTOR warrants that their APP and HSP conforms to the requirements of the Washington Industrial Safety and Health Act (WISHA). CONTRACTOR warrants it will ensure that its employees follow all APPs, HSPs and workplace safety rules and regulations. CONTRACTOR warrants that it will communicate all workplace safety rules to its employees and that it will consistently enforce those rules throughout the length of this contract, no matter who discovers a violation. CONTRACTOR warrants that it will select and furnish to its employees all appropriate safety equipment and participate fully in coordination of all safety issues among all CONTRACTORS/SUBCONTRACTORS on the job. CONTRACTOR warrants that it will make its APP and HSP available and accessible at the site to all its employees. CONTRACTOR agrees that it will have available in its job file weekly documentation relating to CONTRACTOR's safety compliance, identification of hazards or safety violations, actions taken to correct them, disciplinary action taken related to safety, and safety training undertaken. CONTRACTOR warrants that it will provide safety training to all workers as required by WISHA, will conduct safety inspections as required by WISHA and will report all identified hazards and safety deficiencies. CONTRACTOR agrees to undertake any hazard abatement actions required upon the discovery of safety deficiencies. CONTRACTOR warrants and agrees to require each SUBCONTRACTOR to have its own APP and site-specific HSP.

**1.2 PLAN SUBMITTALS**

- A. The table of contents from a written Accident Prevention Program (APP) and a complete site-specific Health and Safety (HSP) Plan for the CONTRACTOR and each SUBCONTRACTOR which identifies anticipated job safety hazards within the scope of CONTRACTOR's and SUBCONTRACTOR's work for all phases of the CONTRACT, including the specific means used to address each hazard prior to starting the job. The APP and HSP must conform to the requirements of the Washington Industrial Safety and Health Act (WISHA). A copy of both the APP table of contents and the HSP shall be furnished prior to starting the job.

**PART 2 PRODUCTS (NOT USED)**

**PART 3 EXECUTION**

- A. CONTRACTOR and all SUBCONTRACTORS shall:
- a. Select all appropriate safety equipment required to do the job and furnish it to workers.
  - b. Participate in coordination of all safety issues among all contractors on the job.
  - c. Make your APP and HSP available and accessible to your workers at the site.
  - e. Communicate all workplace safety rules to employees and consistently enforce those rules, no matter who discovers a violation. Provide weekly documentation relating to safety compliance; identification of hazards or safety deficiencies, and the actions taken to correct them; and disciplinary action related to safety taken; and safety training undertaken.
  - f. Provide safety training to all workers as required by WISHA.
  - g. Conduct safety inspections as required by WISHA and report all identified hazards and safety deficiencies.

**END OF SECTION**

**SECTION - 01400**  
**QUALITY CONTROL**

**PART 1 GENERAL**

**1.1 DEFINITION**

- A. Specific quality control requirements for the Work are indicated throughout the Contract Documents. The requirements of this Section are primarily related to performance of the Work beyond furnishing of manufactured products. The term "Quality Control" includes inspection, sampling and testing, and associated requirements.

**1.2 INSPECTION AT PLACE OF MANUFACTURE**

- A. Unless otherwise indicated, all products, materials, and equipment shall be subject to inspection by the OWNER at the place of manufacture.
- B. The presence of the OWNER at the place of manufacture, however, shall not relieve the CONTRACTOR of the responsibility for furnishing products, materials, and equipment which comply with all requirements of the Contract Documents. Compliance is a duty of the CONTRACTOR, and said duty shall not be avoided by any act or omission on the part of the OWNER.

**1.3 SAMPLING AND TESTING**

- A. Unless otherwise indicated, all sampling and testing shall be in accordance with the methods prescribed in the current standards of the ASTM, NESC or NEC, and 2023 Standard Specifications as applicable to the class and nature of the article or materials considered; however, the OWNER reserves the right to use any generally-accepted system of sampling and testing which, in the opinion of the OWNER will ensure the OWNER that the quality of the workmanship is in full accord with the Contract Documents.
- B. Any waiver by the OWNER of any specific testing or other quality assurance measures, whether or not such waiver is accompanied by a guarantee of substantial performance as a relief from the specified testing or other quality assurance requirements as originally specified, and whether or not such guarantee is accompanied by a performance bond to assure execution of any necessary corrective or remedial Work, shall not be construed as a waiver of any requirements of the Contract Documents.
- C. Notwithstanding the existence of such waiver, the OWNER reserves the right to make independent investigations and tests, and failure of any portion of the Work to meet any of the requirements of the Contract Documents, shall be reasonable cause for the OWNER to require the removal or correction and reconstruction of any such work in accordance with the General Provisions.

**1.4 INSPECTION AND TESTING LABORATORY SERVICE**

- A. Inspection and testing laboratory service shall comply with the following:
  - 1. OWNER will appoint, employ, and pay for services of an independent firm to perform inspection and testing or will perform inspection and testing itself.
  - 2. The OWNER or independent firm will perform inspections, testing, and other services specified in individual specification sections and as required by the OWNER.
  - 3. Reports will be submitted by the independent firm to the OWNER in duplicate, indicating observations and results of tests and indicating compliance or non-compliance with Contract Documents.
  - 4. The CONTRACTOR shall cooperate with the OWNER or independent firm and furnish samples of materials, design mix, equipment, tools, storage and assistance as requested.
  - 5. The CONTRACTOR shall notify OWNER 24 hours prior to the expected time for operations requiring inspection and laboratory testing services.

6. Retesting required because of non-conformance to specified requirements shall be performed by the same independent firm on instructions by the OWNER. The CONTRACTOR shall bear all costs for such retesting at no additional cost to the OWNER.
7. For samples and tests required for CONTRACTOR's use, the CONTRACTOR shall make arrangements with an independent firm for payment and scheduling of testing. The cost of sampling and testing for the CONTRACTOR's use shall be included in the Contract Price.

## **PART 2 PRODUCTS (NOT USED)**

## **PART 3 EXECUTION**

### **3.1 INSTALLATION**

- A. **Inspection:** The CONTRACTOR shall inspect materials or equipment upon the arrival on the jobsite and immediately prior to installation, and reject damaged and defective items.
- B. **Measurements:** The CONTRACTOR shall verify measurements and dimensions of the Work, as an integral step of starting each installation.
- C. **Manufacturer's Instructions:** Where installations include manufactured products, the CONTRACTOR shall comply with manufacturer's applicable instructions and recommendations for installation, to whatever extent these are more explicit or more stringent than applicable requirements indicated in Contract Documents.

**END OF SECTION**



**SECTION - 01505  
MOBILIZATION**

**PART 1 GENERAL**

**1.1 GENERAL**

- A. Mobilization shall include the obtaining of all permits; moving onto the site of all equipment; furnishing and erecting plants, temporary buildings, and other construction facilities; and implementing security requirements; all as required for the proper performance and completion of the Work. Mobilization shall include the following principal items:
1. Moving on to the site of all CONTRACTOR's plant and equipment required for first month operations.
  2. Submittals for ordering long lead time materials and major equipment within ten (10) days of Notice to Proceed.
  3. Installing temporary construction power, wiring, and lighting facilities.
  4. Developing construction water supply.
  5. Providing all on-site communication facilities, including telephones.
  6. Providing on-site sanitary facilities and potable water facilities.
  7. Arranging for and erection of CONTRACTOR's work and storage yard.
  8. Obtaining all required permits.
  9. Having all OSHA required notices and establishment of safety programs.
  10. Having the CONTRACTOR's superintendent at the job site full time.
  11. Preparation and submitting of initial submittals
  12. Project Phasing
- B. Mobilization shall include demobilization of all equipment and facilities from the site and the restoration thereof.

**PART 2 PRODUCTS (NOT USED)**

**PART 3 EXECUTION (NOT USED)**

**END OF SECTION**

**SECTION - 01550  
SITE ACCESS AND STORAGE**

**PART 1 GENERAL**

**1.1 HIGHWAY LIMITATIONS**

- A. The CONTRACTOR shall make its own investigation of the condition of available public and private roads and of clearances, restrictions, bridge load limits, and other limitations affecting transportation and ingress and egress to the site of the Work. It shall be the CONTRACTOR's responsibility to construct and maintain any haul roads required for its construction operations.

**1.2 TEMPORARY CROSSINGS**

- A. **Temporary Bridges:** Wherever necessary, the CONTRACTOR shall provide suitable temporary bridges or steel plates over unfilled excavations, except in such cases as the CONTRACTOR shall secure the written consent of the individuals or authorities concerned to omit such temporary bridges or steel plates, which written consent shall be delivered to the OWNER prior to excavation. All such bridges or steel plates shall be maintained in service until access is provided across the backfilled excavation. Temporary bridges or steel plates for street crossing shall conform to the requirements of the authority having jurisdiction in each case, and the CONTRACTOR shall adopt designs furnished by said authority for such bridges or steel plates, or shall submit designs to said authority for approval, as may be required.
- B. **Street Use:** Nothing herein shall be construed to entitle the CONTRACTOR to the exclusive use of any public street, or parking area during the performance of the Work hereunder, and it shall so conduct its operations as not to interfere unnecessarily with the authorized work of utility companies or other agencies in such streets, or parking areas. Fire hydrants on or adjacent to the Work shall be kept accessible to fire-fighting equipment at all times. Temporary provisions shall be made by the CONTRACTOR to assure the use of sidewalks and the proper functioning of all gutters, storm drain inlets, and other drainage facilities.
- C. **Traffic Control:** See Section 01570 – Traffic Regulations. For the protection of traffic in public or private streets and ways, the CONTRACTOR shall provide, place, and maintain all necessary barricades, traffic cones, warning signs, lights, and other safety devices in accordance with the requirements of the "Manual of Uniform Traffic Control Devices, Part VI - Traffic Controls for Street and Highway Construction and Maintenance Operations," published by U.S. Department of Transportation, Federal Highway Administration (ANSI D6.1).
- D. The CONTRACTOR shall take all necessary precautions for the protection of the WORK and the safety of the public. All barricades and obstructions shall be illuminated at night, and all lights shall be kept illuminated from sunset until sunrise. All signs, signals, and barricades shall conform to the requirements of Subpart G, Part 1926, of the OSHA Safety and Health Standards for Construction.
- E. The CONTRACTOR shall remove traffic control devices when no longer needed, repair all damage caused by installation of the devices, and shall remove post settings and backfill the resulting holes to match grade.

**1.3 PIPE AND MATERIAL STORAGE**

- A. The CONTRACTOR shall not string pipe nor stockpile imported earth materials on streets or in places which interfere with vehicular traffic.
- B. The CONTRACTOR may enter into an agreement with local property owners for temporary storage of project materials as required. If the CONTRACTOR does so, the costs for all access improvements,

TESC measures, site grading, fencing, security, permits, and any other site improvements are the responsibility of the CONTRACTOR.

**PART 2 PRODUCTS (NOT USED)**

**PART 3 EXECUTION (NOT USED)**

**END OF SECTION**

**SECTION - 01560  
ENVIRONMENTAL CONTROLS**

**PART 1 GENERAL**

**1.1 DESCRIPTION**

- A. This section specifies temporary environmental controls required to be maintained during construction in addition to Section 02270 – Erosion and Sediment Control.
- B. The CONTRACTOR shall prepare a Storm Water Pollution Prevention Plan (SWPPP). The SWPPP will contain detailed plans to cover all exposed soils (with plastic sheets, straw mulch, etc.) to prevent stormwater from conveying soils into the water body. Soil stabilization activities in the vicinity of the impaired water body will not include the use of phosphorus-containing fertilizers, compost, or other products that could cause excess phosphorus or other nutrients to be discharged. In addition, sediment control measures (silt fence, waddles, etc.) will be installed and maintained to ensure that sediment-laden stormwater is not discharged during the construction activity.
- C. The CONTRACTOR shall prepare a Spill Prevention, Control and Countermeasures Plan (SPCC) in conformance with Section 1-07.15(1) of the Standard Specifications.

**1.2 SUBMITTALS**

- A. Construction SWPPP in conformance with Washington State Department of Ecology Stormwater Management Manual for Western Washington (SWMMWW). Temporary erosion and sediment control BMPs the Contractor anticipates using may be hand drawn on 11x17-inch copies of construction plans supplied by the Owner.
- B. SPCC Plan in conformance with Section 1-07.15(1) of the Standard Specifications.

**PART 2 PRODUCTS (NOT USED)**

**PART 3 EXECUTION**

**3.1 TEMPORARY DAMS**

- A. Except in time of emergency, earth dams are not acceptable at catch basin openings, local depressions, or elsewhere. Temporary dams of sand bags, asphaltic concrete, or other acceptable material will be permitted when necessary to protect the work, provided their use does not create a hazard or nuisance to the public. Such dams shall be removed from the site as soon as they are no longer necessary.

**3.2 AIR POLLUTION CONTROL**

- A. The CONTRACTOR shall not discharge smoke, dust, and other contaminants into the atmosphere that violate the regulations of legally constituted authorities. Minimize dust nuisance by cleaning, sweeping, and sprinkling with water, or other means. The use of water, in amounts resulting in mud on public streets, is not acceptable as a substitute for sweeping or other methods.

**3.3 NOISE CONTROL**

- A. The CONTRACTOR shall perform all work in compliance with the local jurisdiction's Noise Ordinance, except where additional restrictions are applicable. The CONTRACTOR shall schedule noisy operations to minimize their duration.

- B. The CONTRACTOR shall use whatever means necessary to comply with the Noise Ordinance. The CONTRACTOR shall be responsible for all costs necessary to reduce noise levels to those specified in the Noise Ordinance or to obtain a variance from the specific levels.
- C. The CONTRACTOR shall provide the following noise abatement equipment or operate construction equipment in the following manner so as to avoid exceeding noise limitations:
  1. Each internal combustion engine, used for any purpose on the job or related to the job, shall be equipped with a muffler of a type recommended by the manufacturer. No internal combustion engine shall be operated on the project without said muffler.
  2. Equipment that cannot meet the noise levels specified under the local Noise Ordinance shall be quieted by use of improved exhaust mufflers or other means.
  3. Noisy portable equipment, such as generators, compressors or pumps shall be located as far away from sensitive noise receptor areas as practicable. (Noise sensitive receptors include residences.)
  4. Noise barriers shall be constructed around stationary construction equipment which has to be utilized at locations near sensitive noise receptors.
  5. Idling equipment shall be shut off when not in active use.

### 3.4 WATER AND EROSION CONTROL

- A. **Temporary Drainage:** Conform to the regulations and requirements of legally authorized surface water management agencies.
- B. Keep trenches and areas of excavations free from water as required to permit continuous progress of, or to prevent damage to, the work or the work of others.
- C. Discharge dewatering waters and runoff or other waters collected in or intercepted by excavations under the work of this Contract in conformance with all permits. The CONTRACTOR must obtain approval from the appropriate local sewer authority or drainage authority, in writing, for any discharge to local sewers. The CONTRACTOR's operations shall be conducted in such a manner as to prevent sediment from reaching the storm drains and surface waters.
- D. Prevent solids or turbid runoff from entering waterways. No dirt, sediments, cement leachate or other material harmful to fish shall enter fish bearing waters. Cover and secure excavated area, spoils piles and imported or stored fill materials. Cut and cover techniques, storm drains filter socks, straw bales around construction sites, silt fencing and similar erosion control measures shall be employed as required to prevent contamination of local waterways.
- E. Erosion control measures shall be in accordance with Section 02270 – Erosion and Sediment Control Drawings and general notes, and shall be installed prior to excavation, clearing or grading activities.

### 3.5 PROGRESS CLEANING AND SITE MAINTENANCE

- A. Maintain areas free of waste materials, debris, and rubbish. Maintain site in a clean and orderly condition.
- B. Remove waste materials, debris and rubbish from the site immediately upon such materials becoming unfit for use in the work. In the event this material is not removed, the OWNER reserves the right to have the material removed and the expense charged to the CONTRACTOR.
- C. Prevent dirt and dust from escaping trucks departing the site by covering dusty loads, washing truck tires before leaving the site, or other methods as applicable.
- D. The CONTRACTOR is responsible for controlling dust and mud within the project limits. All streets outside the project limits used by the CONTRACTOR during the execution of this Contract shall be kept clean. The CONTRACTOR shall use watering trucks equipped with high-velocity water jets and low-head sprinkling devices, power sweepers, and any other pieces of equipment necessary to render the streets free

of all mud, debris, and foreign materials. Any damage caused by dust or mud accumulation on the streets and in the storm drain system shall be the sole responsibility of the CONTRACTOR.

- E. Watering trucks may be used on paved streets with an adequate storm drainage system. Watering trucks shall not be used on streets where, in the opinion of the OWNER, mud could be created, causing a nuisance. Where water flushing is not allowed, street sweepers (not power brooms) shall be used.
- F. Sweep or flush all surface roadways upon completion of each day's activities. Equipment required for this operation shall be on the job site or available at all times. Failure to have this equipment on the job site or available may necessitate a shutdown of the project.
- G. Clean all roadways, streets, and appurtenances, including sidewalks and paths which are open for public use, of all material or debris which has been dropped or otherwise deposited thereon, as a result of CONTRACTOR on- and off-site operations, at the conclusion of each working day, and at such other times as deemed necessary by the OWNER to ensure the safety of the traveling public and to prevent inconvenience to the public and owners of private property adjacent to the project.
- H. Any violation of the above requirements will be sufficient grounds for the OWNER to order the roadways, streets and appurtenances cleaned or sprinkled by others, and to deduct all costs of such cleaning or sprinkling from any money due, or to become due to the CONTRACTOR.

### 3.6 TREE AND PLANT PROTECTION

- A. Protect existing trees as directed by the OWNER. The CONTRACTOR shall be responsible for restoration of trees and plants damaged by the CONTRACTOR's operation or damaged as a result of insufficient or improper protection, as determined by the OWNER.

### 3.7 OIL SPILL PREVENTION AND CONTROL

- A. **Regulations:** The CONTRACTOR is advised that discharge of oil from equipment or facilities into state waters or onto adjacent land is not permitted under Washington State water quality regulations.
- B. **Responsibility:** The CONTRACTOR shall be responsible for prevention, containment, and cleanup of spilling of oil, fuel and other petroleum products used in the CONTRACTOR's operations. All such prevention, containment and cleanup costs shall be borne by the CONTRACTOR. The CONTRACTOR shall, at a minimum, take the following measures regarding oil spill prevention, containment and cleanup.
- C. **Minimum Precautions:**
  - 1. Fuel hoses, lubrication equipment, hydraulically operated equipment, oil drums, and other equipment and facilities shall be inspected regularly for drips, leaks, or signs of damage, and shall be maintained and stored properly to prevent spills. Proper security shall be maintained to discourage vandalism.
  - 2. All land-based oil and products storage tanks shall be diked or located so as to prevent spills from escaping to the water. Diking and subsoil's shall be lined with impervious material to prevent oil from seeping through the ground and dikes.
  - 3. All visible floating oils shall be immediately contained with booms, dikes, or other appropriate means and removed from the water prior to discharge into state waters. All visible oils on land shall be immediately contained using dikes, straw bales, or other appropriate means and removed using sand, ground clay, sawdust, or other absorbent material, which shall then be properly disposed of by the CONTRACTOR.
  - 4. In the event of any oil or product discharges into public waters, or onto land with a potential for entry into public waters, the CONTRACTOR shall immediately notify the following agencies at their listed 24-hour response numbers:
    - a. Washington DOE Northwest Regional Office, Telephone No. (425) 649-7000.
    - b. U.S. Coast Guard Telephone No. (206) 217-6232.

- c. Maintain on the job site, in the vicinity of ongoing work, the following spill response and containment materials:
  - 1) Oil-absorbent booms: minimum four (4) each, five (5) feet long.
  - 2) Oil-absorbent pads or bulk material, adequate for coverage of 200 square feet of surface area, minimum.
  - 3) Straw bales.
  - 4) Dry all.
  - 5) Gloves.
  - 6) Plastic bags.

### **3.8 CULTURAL RESOURCES FINDINGS**

#### **A. References:**

- 1. The CONTRACTOR shall adhere to the National Historic Preservation Act of 1966 and 36 CFR 800 which provide for the preservation of potential historical architectural, archaeological, or cultural resources (hereinafter called “cultural resources”).
- 2. The CONTRACTOR shall conform to the applicable requirements of the National Historical Preservation Act of 1966 as it relates to the preservation of cultural resources and fair compensation to the CONTRACTOR for delays resulting from such cultural resources investigations.

#### **B. Findings Procedures:**

- 1. Attached in Appendix C is a copy of the Archaeological Inadvertent Discovery Plan. In the event of such a discovery the Contractor shall comply with the plan.

**END OF SECTION**

**SECTION - 01570  
TRAFFIC REGULATIONS**

**PART 1 GENERAL**

**1.1 DESCRIPTION OF WORK**

- A. This section specifies furnishing, erecting, and maintaining, per the Approved Traffic Control Plans; temporary barricades, signs, flaggers, off duty police officers, lights, road surfaces, detours and other safeguards necessary to protect life, health and safety of the public and workers during performance of the work.
- B. Single lane, two-way traffic with flaggers may be used for project areas during normal work hours for road side work, shoulder construction and delivery of materials.
- C. Access to residences and businesses shall also be maintained. Temporary closure of driveways shall be minimized. Full driveway access shall be restored after work hours.
- D. Coordination of advanced notice to traveling public and adjacent residents and business shall be the responsibility of the CONTRACTOR.
- E. Furnishing, installing, programing, and maintaining Portable Changeable Message Signs.

**1.2 CONTRACTOR RESPONSIBILITY**

- A. The traffic control plan or plans appearing in the contract documents show a method of handling traffic. All flaggers are to be shown on the traffic control plan except for emergency situations. The CONTRACTOR shall designate and adopt in writing the specific traffic control plan or plans required for their method of performing the work. If the CONTRACTOR's methods differ from the contract traffic control plan(s), the CONTRACTOR shall propose modification of the traffic control plan(s) by showing the necessary construction signs, flaggers, and other traffic control devices required for the project. The CONTRACTOR's modified traffic control plan(s) shall be in accordance with the established standards for plan development as shown in the MUTCD, Part VI. The CONTRACTOR's letter designating and adopting the specific traffic control plan(s) or any proposed modified plan(s) shall be submitted to the OWNER for approval at least 30 calendar days in advance of the time the signs and other traffic control devices will be required. The CONTRACTOR shall be solely responsible for providing copies of the approved Traffic Control Plans to the Traffic Control Supervisor and jurisdictions.
- B. The OWNER will grant to the CONTRACTOR all traffic right-of-way and road crossing permits from the appropriate jurisdiction to accomplish the work.
- C. The CONTRACTOR and his surety shall be liable for injuries and damages to persons and property suffered by reason of the CONTRACTOR's operations or negligence.
- D. When ordered by the Engineer, the CONTRACTOR shall provide advanced notice of work through the use of Portable Changeable Message Signs (PCMS). Advance notice signs shall be placed 5 days in advance of commencement of earthwork or other operations requiring long duration lane closures. Advanced notice time shall include 2 consecutive weekends.
- E. Provide a Traffic Control Supervisor in accordance with Section 1-10.2(1)B of the Standard Specifications for the duration of the time when traffic control signs, devices, or flaggers and spotters are in use.



### 1.3 OWNER'S AUTHORITY

- A. If the CONTRACTOR fails or refuses to provide and maintain all traffic controls required by the Contract Documents or ordered by the OWNER, the OWNER may:
  - 1. Suspend all work without further notice to the CONTRACTOR or the CONTRACTOR's surety until the CONTRACTOR complies with requirements.
  - 2. At the CONTRACTOR's expense immediately obtain the services of a uniformed police officer.
  - 3. At the CONTRACTOR's expense provide, erect, maintain, and remove required traffic control devices.
- B. The OWNER will deduct all related costs from any payments due or coming due to the CONTRACTOR.
- C. If the CONTRACTOR fails or refuses to complete and furnish Contractor's Daily Report of Traffic Control –Traffic Control Log and Contractor's Daily Report of Traffic Control – Summary, the OWNER shall engage a third party to complete the reports and deduct any excess cost over the Contract amount for Traffic Control Supervisor from payments due the CONTRACTOR. Upon the CONTRACTOR's receipt of three written notices, by the Engineer, of the CONTRACTOR's failure to fulfill these Contract obligations, the OWNER shall exercise its right to complete this work and withhold excess amounts from payments due the CONTRACTOR.
- D. The above options shall not bar the OWNER from exercising other remedies as a result of the CONTRACTOR's failure or refusal to comply with a contractual obligation.

### 1.4 QUALITY ASSURANCE

- A. Referenced Standards:
  - 1. MUTCD: U.S. Department of Transportation, Federal Highway Administration: Manual on Uniform Traffic Control Devices, Part VI, "Work Zone Traffic Control Standards and Guidelines"
  - 2. Washington State Department of Transportation Standard Plans

### 1.5 SUBMITTALS

- A. **Procedures:** Section 01300 - Contractor Submittals.
- B. Submit a Notification Plan within 10 days of the effective date of the Notice to Proceed and update for monthly coordination/progress meetings a notification procedure and plan to maintain access for adjacent or affected properties and businesses. Notification procedure and access plan should include:
  - 1. Advanced notice time
  - 2. Method of notice
  - 3. Detail of how access will be maintained
  - 4. A copy of a standard written notice with the CONTRACTOR's contact name and 24-hour phone number
  - 5. Estimated week of construction within 150 feet of affected property.
  - 6. Estimated number of days that construction will be fronting the property.
  - 7. Special issues for maintaining access.

### 1.6 CONSTRAINTS

- A. Multiple construction crews are allowed, however, two consecutive street intersections shall not be impacted at the same time.
- B. Maintain pedestrian and bicycle access at all times where practical.

- C. **Traffic Control Requirements:** Consider and include the following street and lane closure restrictions:
1. Vehicular and pedestrian routing on streets where the work is not being performed shall not be revised.
  2. Annotate proposed location of barricades, lighting, signing, temporary striping and other traffic control devices.
  3. All Flaggers directing traffic shall possess a current Flagger Certification Card
  4. Make arrangements for emergency exiting from buildings within and immediately adjacent to the construction site.
  5. At each site where a two-way roadway is restricted to one lane of two-way traffic, provide a minimum of two certified flaggers in order to insure safe and effective movement of traffic through the constricted zone. Provide three certified flaggers when the construction zone length causes sight distance or communication problems between a two member team of flaggers to operate safely.
  6. Submit for approval any specific streets not addressed above which will have a traffic impact.
  7. Maintain emergency access, access to businesses, public service buildings and residences at all times. Provide a minimum of one week notice when driveway access will be restricted or modified. Provide cleared residential driveway access at the end of every work day. Provide businesses, public service buildings, and industrial sites driveway access during their operating hours.
  8. Provide local access to all businesses, industrial sites and residences. Provide a certified flagger to reduce conflicts between local access traffic and construction crews and/or heavy equipment whenever local access is required into/out of the construction zone.
  9. Channel traffic flow into the work zone per approved Traffic Control Plan.
- D. Refer to Construction Timing Constraints Summary at the end of Section 01313 for specific restrictions.

## 1.7 JOB COORDINATION

- A. Coordinate all construction to offer the least possible obstruction and inconvenience to public.
- B. Do not open areas of work and leave the area unfinished; finish work in process insofar as practical. All work areas must be filled or covered at the end of the work shift.
- C. Coordinate with property and business owners in order to maintain convenient access for local traffic to private properties along the line of work at all times and/or as specified in paragraph 01570-3.2 and on the Drawings.
- D. Coordinate revisions to existing traffic control with the affected agencies. Keep traffic controls in operation unless otherwise required by the OWNER for the benefit of the traveling public during progress of the work. As work progresses and as conditions permit, reset temporarily relocated or removed traffic and street name signs in their permanent location. Replace or repair signs and other traffic control devices damaged or lost. The option whether a sign can be repaired or is to be replaced is the OWNER's.
- E. Keep existing street lighting systems in operation during progress of the work.

## 1.8 NOTIFICATIONS

- A. Obtain written approval from the OWNER and the jurisdiction before scheduling to partially or completely close any street.
- B. Detail notification for the time of commencement, completion of the work, names of streets to be closed, schedule of operation, routes of detours, etc.

- C. To accommodate emergency vehicle rerouting, notify in writing, local fire and law enforcement authorities and other affected agencies not less than 72 hours prior to construction operations which deviate or delay traffic from the existing traffic patterns.
  - 1. Fire
    - a. City of Burlington (360) 755-0261
  - 2. City of Burlington
    - a. Police (360) 755-0921
  - 3. Skagit County
    - a. Sheriff (360) 336-9450
  - 4. Washington State Patrol
    - a. Burlington Office (360) 757-7553
    - b. Marysville (360) 654-1204
- D. Notification of the residents living adjacent to the work will be by the CONTRACTOR a minimum of 48-hours in advance of the construction in the area of work. The notification procedure and access plan is used for the advance notice and contains a general description of the purpose of construction work and proposed schedule.
- E. Directly inform individual owners or household residents at least 48 hours in advance of beginning the work to minimize or eliminate inconveniences to the public. Inform owners of work which blocks the use of the property in any way by construction or equipment.
- F. Advanced notice of lane closure signs shall be placed 10 days in advance, including 2 consecutive weekends, of lane closures unless indicated otherwise on the drawings.
- G. Notify the local school district at least one week in advance of any construction that may disrupt school bus routes.

## **1.9 MEETINGS**

- A. Prior to the beginning of hauling materials, hold an awareness meeting with truck drivers regarding traffic concerns discussed at the preconstruction meeting, including methods to reduce congestion, obeying speed limits, specific locations identified as safety hazards, and allowable haul times.
- B. During construction, discuss traffic safety and traffic concerns at the regularly scheduled progress meetings. Reinforce the importance of traffic safety and update the crews regarding safety in the particular area where construction is occurring at the time and communicate feedback received from the local jurisdictions.

## **PART 2 PRODUCTS**

### **2.1 SPECIAL SIGNS**

- A. Signs with special or non-standard messages may be included as part of the Traffic Control Plan as required to properly convey information to the motorist or pedestrian. Use signs in accordance with the requirements in paragraph 01570 - 1.2.
- B. All signs shall conform and meet the minimum standards established in the latest adopted edition of the "Manual on Uniform Traffic Control Devices" (MUTCD) U.S. Department of Transportation, Federal Highway Administration, or the accepted Standards of the governing agency.
- C. Portable Changeable Message Signs in accordance with Section 9-35.5 of the Standard Specifications.

## **PART 3 EXECUTION**

### 3.1 GENERAL

- A. Comply with all requirements of the latest issue of the “Manual on Uniform Traffic Control Devices” for In-Street Work, local permits obtained by the CONTRACTOR, and the following permits obtained by the OWNER:
  - 1. Skagit County – Right-of-Way Use Permit
- B. The CONTRACTOR shall comply with all local permits, conditions, and mitigation requirements related to the use of area roadways affected by construction activities. The CONTRACTOR shall haul only during permitted hours.
- C. Comply with the following:
  - 1. When the CONTRACTOR, OWNER, Police Department, Skagit County, determine it is necessary, additional flaggers shall be stationed within the construction area to mitigate congestion caused by construction.
  - 2. Construction equipment shall be parked off the traveled way with adequate barricades and flashers provided at night to lessen traffic hazards associated with construction activity.
  - 3. The CONTRACTOR shall have steel plate and steel beams available on the job site for bridging of trench cuts to mitigate safety hazards and problems associated with emergency and property access requirements.
  - 4. CONTRACTOR shall inspect and maintain the control site at least once per work shift.
  - 5. CONTRACTOR shall remove or cover all non-applicable signs when not in use.

### 3.2 TRAFFIC MAINTENANCE

- A. Take all necessary measures to maintain a normal flow of vehicular and pedestrian traffic to prevent accidents and to protect the work throughout the construction stages until completion of the work. Make the necessary arrangements to reroute traffic, provide and maintain barriers, cones, guards, barricades, and construction warning and regulatory signs. Make all regulatory devices suitable for nighttime operation. Take effective measures necessary to protect all other portions of the work during construction and until completion. This includes providing and maintaining all necessary barricade lights, construction signs, guards, temporary crossovers, and flaggers in accordance with the requirements referenced in paragraph 01570-1.2.
- B. Maintain emergency exiting from buildings within and immediately adjacent to the construction site.
- C. Maintain vehicular traffic at all locations to the greatest extent possible and reduce and reroute traffic only for the shortest time possible consistent with effective construction operations. Do not block required travel lanes including trucks delivering materials. Material deliveries and other related trucking activities to occur in the CONTRACTOR's protected work area. Upon completion of a segment of work in streets traffic shall be restored to normal flow as soon as possible. Maintain existing directional operation of street systems at all times.
- D. Access by emergency vehicles shall be maintained at all times in all roadways. Use temporary covers over cuts to accommodate traffic. Notification shall be given to the OWNER and the fire station chief prior to limitation of access in any section of the roadway.
- E. Maintain pedestrian movements through construction areas. Facilities for pedestrians include provisions for the safe movement of mobility and sight-impaired individuals. This includes temporary ramps.
- F. Coordinate traffic control plan with other contractor's traffic control plan for all work.
- G. Inspect the control area at least once per work shift. Reset and repair all traffic control devices immediately.

### 3.3 ACCESS

- A. Maintain access for emergency vehicles to private properties and businesses at all times. Access to private property shall be restored at the end of each work shift.
- B. Where, during some urgent stages of construction, the OWNER determines that temporary closure of an access to a property is unavoidable, coordinate the closure with the property and business owner.
- C. When the abutting business or owners' access across the right-of-way is to be temporarily closed and replaced by other access, place an interim surface to restore access. Arrange work so that access is available to all properties at all times work is not occurring. Provide unimpeded local access to properties during non-construction periods.

### 3.4 SAFETY

- A. Use adequate safeguards, safety devices and protective equipment. Take any actions needed to protect life, health and safety of the public and to protect property in connection with the performance of the work.
- B. Use such flaggers, signs and other devices, and erect and maintain all barricades, guards, standard construction signs, warning signs and detour signs, as are necessary to warn and protect the public at all times from injury or damage as a result of the construction operations.
- C. Where flaggers are employed to safeguard traffic, use flagger equipment in accordance with the referenced standards except for personal wearing apparel. This equipment must be used by flaggers while actually flagging traffic. All flaggers are required to possess a current flagging certification card.
- D. Furnish any standard signs as well as any other appropriate signs prescribed by the OWNER as applicable and necessary for the work. Erect signs on posts and supports and maintain them in a neat and safe condition until the necessity for them has ceased. When the need for any sign has ceased, upon approval by the OWNER, take down such sign. All control signs necessary for nighttime traffic control or remaining in place during the night shall be fully reflectorized.
- E. Safeguard and direct traffic after the existing signs have been removed. Preserve and maintain traffic control and street name signs. Signs and other traffic control devices damaged or lost by the CONTRACTOR shall be replaced or repaired. The option whether a sign can be repaired or be replaced shall be the OWNER's. Such decision shall be final and binding on the CONTRACTOR.
- F. Patrol traffic control areas and reset all disturbed signs and traffic control devices immediately. Remove or cover all non-applicable signs during periods not needed.
- G. Use flaggers, barricades, lights and signs for protection of the work and the public at all times.
- H. The OWNER may without further notice supply such material and equipment as necessary and deduct all of the costs thereof from any payments due, upon CONTRACTOR failure to immediately supply flaggers; erect, maintain and remove barricades and lights, and erect, maintain and remove standard signs when ordered to do so by the OWNER.
- I. During the hours of non-construction, maintain all existing traffic lanes safe for vehicular traffic. Leave all unfinished work in a safe, non-hazardous condition to the public in Accordance with "Safety Standards for Construction Work," Department of Labor and Industries, Chapter 296-155 WAC.

### **3.5 SIGNS**

- A. Signs are required for the duration of construction from commencement of earth moving activities through substantial completion.
- B. Replace signs that are stolen, vandalized or damaged before work commences.

### **3.6 TRAFFIC CONTROL SUPERVISOR**

- A. The Contractor shall have one (1) Traffic Control Supervisor on duty for the period of time work is being conducted under traffic and traffic control measures are in place. No more than one Traffic Control Supervisor will be allowed.
- B. The Traffic Control Supervisor (TCS) shall fulfill all duties listed in Section 1-10.2(1)B of the Standard Specifications. No payment will be provided for any day in which a Contractor's Daily Report of Traffic Control – Summary and Traffic Control Log are not completed. A copy of each is attached hereto.
- C. Failure to complete the Contractor's Daily Report of Traffic Control -Traffic Control Log or the Contractor's Daily Report of Traffic Control – Summary will result in no measurement for this work.

**END OF SECTION**

# **Attachment A**

## **Contractor's Daily Report of Traffic Control**

Use separate sheets for each setup. (May be altered to record Class A signs.)

Page
Contract Number
SR Number
Day
Date

Sta A	Setup				Sta B
	Station	Time	Station	Time	
◇	-		-		◇
◇	-		-		◇
◇	-		-		◇
◇	-		-		◇
◇	-		-		◇
<b>Work Area</b>					
◇	-		-		◇
◇	-		-		◇
◇	-		-		◇
◇	-		-		◇
◇	-		-		◇
Sta C	↑	One Way Traffic (one or more lanes)	↑		Sta D
	↓	Two Way Traffic (two or more lanes)	↑		

**Legend**  
(List of Signs Used)

1	_____
2	_____
3	_____
4	_____
5	_____
6	_____
7	_____
8	_____

Cones Yes     No     
  Piloted Yes     No

Per Approved Plan Yes     No     
 \_\_\_\_\_ Plan Title

Flagger/Spotter Sta	Start	End	Hours
Station A			
Station B			
Station C			
Station D			

**Other Traffic Control Labor**

Name	Start	End	Hours

\_\_\_\_\_ Contractor

\_\_\_\_\_ Contractor's Traffic Control Supervisor's Signature

Type of Traffic Control	Time Set Up	Time(s) Checked	Time Removed

To be Completed by Contractor's Traffic Control Supervisor (TCS)

DOT Form 421-040B EF  
Revised 03/2008

Distribution: White - Contractor; Canary - Project Engineer





**SECTION - 01600**  
**PRODUCTS, MATERIALS, EQUIPMENT AND SUBSTITUTIONS**

**PART 1 GENERAL**

**1.1 DEFINITIONS**

- A. The word "Products", as used herein, is defined to include purchased items for incorporation into the Work, regardless of whether specifically purchased for the project or taken from CONTRACTOR's stock of previously purchased products. The word "Materials," is defined as products which must be substantially cut, shaped, worked, mixed, finished, refined, or otherwise fabricated, processed, installed, or applied to form units of work. The word "Equipment" is defined as products with operational parts, regardless of whether motorized or manually operated, and particularly including products with service connections (wiring, piping, and other like items). Definitions in this paragraph are not intended to negate the meaning of other terms used in the Contract Documents, including "specialties," "systems," "structure," "finishes," "accessories," "furnishings," special construction," and similar terms, which are self-explanatory and have recognized meanings in the construction industry.
- B. Neither "Products" nor "Materials" nor "Equipment" includes machinery and equipment used for preparation, fabrication, conveying and erection of the Work.

**1.2 QUALITY ASSURANCE**

- A. **Source Limitations:** To the greatest extent possible for each unit of work, the CONTRACTOR shall provide products, materials, and equipment of a singular generic kind from a single source.
- B. **Compatibility of Options:** Where more than one choice is available as options for CONTRACTOR's selection of a product, material, or equipment, the CONTRACTOR shall select an option which is compatible with other products, materials, or equipment. Compatibility is a basic general requirement of product, material and equipment selections.

**1.3 PRODUCT DELIVERY AND STORAGE**

- A. The CONTRACTOR shall deliver and store products in accordance with manufacturer's written recommendations and by methods and means which will prevent damage, deterioration, and loss including theft. Delivery schedules shall be controlled to minimize long-term storage of products at the site and overcrowding of construction spaces. In particular, the CONTRACTOR shall ensure coordination to ensure minimum holding or storage times for flammable, hazardous, easily damaged, or sensitive materials to deterioration, theft, and other sources of loss.

**1.4 TRANSPORTATION AND HANDLING**

- A. Products shall be transported by methods to avoid damage and shall be delivered in undamaged condition in manufacturer's unopened containers and packaging.
- B. The CONTRACTOR shall provide equipment and personnel to handle products, materials, and equipment by methods to prevent soiling and damage.
- C. The CONTRACTOR shall provide additional protection during handling to prevent marring and otherwise damaging products, packaging, and surrounding surfaces.

**1.5 STORAGE AND PROTECTION**

- A. Products shall be stored in accordance with manufacturer's written instructions and with seals and labels intact and legible. Sensitive products shall be stored in accordance with manufacturer's recommendations.

- B. For exterior storage of fabricated products, products shall be placed on sloped supports above ground. Products subject to deterioration shall be covered with impervious sheet covering and ventilation shall be provided to avoid condensation.
- C. Loose granular materials shall be stored on solid flat surfaces in a well-drained area and shall be prevented from mixing with foreign matter.
- D. Storage shall be arranged to provide access for inspection. The CONTRACTOR shall periodically inspect to assure products are undamaged and are maintained under required conditions.

#### **1.6 MAINTENANCE OF STORAGE**

- A. The CONTRACTOR shall comply with manufacturer's product storage requirements and recommendations.
- B. The CONTRACTOR shall ensure that surfaces of products exposed to the elements are not adversely affected and that weathering of finishes does not occur.
- C. The CONTRACTOR shall maintain manufacturer-required environmental conditions continually.
- D. For mechanical and electrical equipment, the CONTRACTOR shall provide a copy of the manufacturer's service instructions with each item and the exterior of the package shall contain notice that instructions are included.
- E. Products shall be serviced on a regularly scheduled basis, and a log of services shall be maintained and submitted as a record document prior to acceptance by the OWNER in accordance with the Contract Documents.

#### **1.7 PROPOSED SUBSTITUTES OR "OR APPROVED EQUAL" ITEM**

- A. Whenever materials or equipment are indicated in the Contract Documents by using the name of a proprietary item or the name of a particular Supplier, the naming of the item is intended to establish the type, function, and quality required. If the name is followed by the words "or approved equal" indicating that a substitution is permitted, materials or equipment of other suppliers may be accepted if sufficient information is submitted by the CONTRACTOR to allow the OWNER to determine that the material or equipment proposed is equivalent or equal to that named, subject to the following requirements:
  - 1. Any item for which the Contractor seeks a substitution, such substitution request is required to be submitted two full business days prior to bid opening. Only those items approved for substitution through a formal Addenda published one business day, or more, prior to bid opening will be accepted for incorporation into the work. Submitting a proposed substitution prior to two business days in advance of bid opening does not guarantee approval.
  - 2. The burden of proof as to the type, function, and quality of any such substitute product, material or equipment shall be upon the CONTRACTOR.
  - 3. The OWNER will be the sole judge as to the type, function, and quality of any such substitute and the OWNER's decision shall be final.
  - 4. The OWNER may require the CONTRACTOR to furnish at the CONTRACTOR'S expense additional data about the proposed substitute.
  - 5. The OWNER may require the CONTRACTOR to furnish at the CONTRACTOR'S expense a special performance guarantee or other surety with respect to any substitute.
  - 6. Acceptance by the OWNER of a substitute item proposed by the CONTRACTOR shall not relieve the CONTRACTOR of the responsibility for full compliance with the Contract Documents and for adequacy of the substitute.
  - 7. The CONTRACTOR shall be responsible for resultant changes including design and construction changes and all additional costs resulting from the changes which the accepted substitution requires in the CONTRACTOR's Work, the Work of its subcontractors and of other contractors, and shall effect such changes without cost to the OWNER.

- B. The procedure for review by the OWNER will include the following:
1. If the CONTRACTOR wishes to provide a substitute item, the CONTRACTOR shall make written application to the OWNER a minimum of two full business days prior to bid opening
  2. Wherever the submission of a proposed substitute material or equipment has been judged unacceptable by the OWNER, is not timely, or incomplete, the CONTRACTOR shall provide the material or equipment indicated in the Contract Documents. Only those substitutions noticed through a formal Addendum will be accepted for incorporation into the Work.
  3. The CONTRACTOR shall certify that the proposed substitute will perform adequately the functions and achieve the results called for by the general design and be similar and of equal substance to that indicated and be suited to the same use as that specified.
  4. The OWNER will evaluate each proposed substitute within a reasonable period of time.
  5. As applicable, no shop drawing submittals shall be made for a substitute item nor shall any substitute item be ordered, installed, or utilized without the OWNER'S prior written acceptance of the CONTRACTOR'S substitution request.
- C. The CONTRACTOR's substitution request transmitted with the OWNER's standard form, which is appended at the end of this section, or the CONTRACTOR's standard form approved by the OWNER, shall contain the following statements and information which shall be considered by the OWNER in evaluating the proposed substitution:
1. The evaluation and acceptance of the proposed substitute will not prejudice the CONTRACTOR's achievement of substantial completion on time.
  2. Whether or not acceptance of the substitute for use in the Work will require a change in any of the Contract Documents to adapt the design to the proposed substitute.
  3. Whether or not incorporation or use of the substitute in connection with the Work is subject to payment of any license fee or royalty.
  4. All variations of the proposed substitute from the items originally specified will be identified.
  5. Available maintenance, repair, and replacement service will be indicated. The manufacturer shall have a local service agency (within 50 miles of the site) which maintains properly trained personnel and adequate spare parts and is able to respond and complete repairs within 24 hours.
  6. Itemized estimate of all costs that will result directly or indirectly from acceptance of such substitute, including cost of redesign and claims of other contractors affected by the resulting change.
  7. Itemized proposed savings that the OWNER will realize.
- D. OWNER reserves the right to require proposed product to comply with color and pattern of specified product if necessary to secure design intent.
- E. Substitutions will be rejected if:
1. Submittal is not through the Contractor with his stamp of approval.
  2. Requests are not made in accordance with this Section.
  3. In the OWNER's opinion, acceptance will require substantial revision of the original design.
  4. In the OWNER's opinion, substitution will not perform adequately the function consistent with the design intent.

**PART 2 PRODUCTS (NOT USED)**

**PART 3 EXECUTION (NOT USED)**

**END OF SECTION**



# Substitution Request Form

To: PUD No. 1 of Skagit County  
1415 Freeway Drive  
Mount Vernon, WA 98273

Project: North Burlington Pipeline Replacement  
Project  
 Attention: Michelle Peters

Specified Item:

Section	Page	Paragraph	Description
---------	------	-----------	-------------

The undersigned requests consideration of the following:

**Proposed Substitution:** \_\_\_\_\_

Attached data includes product description, specifications, drawings, photographs, performance and test data adequate for evaluation of the request. Applicable portions of the data are clearly identified.

The undersigned states that the following paragraphs, unless modified on attachments, are correct:

1. The proposed substitution does not affect dimensions shown on Drawings and will not require a change in any of the Contract Documents.
2. The undersigned will pay for changes to the design, including Engineering design, detailing, and construction costs caused by the request substitution which is estimated to be \$\_\_\_\_\_.
3. The proposed substitution will have no adverse effect on other contractors, the construction schedule (specifically the date of substantial completion), or specified warranty requirements.
4. Maintenance and service parts will be locally available for the proposed substitution.
5. The incorporation or use of the substitute in connection with the work is not subject to payment of any license fee or royalty.

The undersigned further states that the function, appearance, and quality of the Proposed Substitution are equivalent or superior to the Specified item.

Submitted by **Contractor:** \_\_\_\_\_ Reviewed by **OWNER:** \_\_\_\_\_

Signature \_\_\_\_\_  Accepted  Accepted as Noted  
 Not Accepted  Received too Late

Firm \_\_\_\_\_ By: \_\_\_\_\_

\_\_\_\_\_ Title: \_\_\_\_\_

Date: \_\_\_\_\_ Date: \_\_\_\_\_

Telephone: \_\_\_\_\_ Remarks: \_\_\_\_\_

Attachments:

**SECTION - 01700  
PROJECT CLOSEOUT**

**PART 1 GENERAL**

**1.1 FINAL CLEANUP**

- A. The CONTRACTOR shall promptly remove from the vicinity of the completed work, all rubbish, unused materials, concrete forms, construction equipment, and temporary structures and facilities used during construction. Final acceptance of the WORK by the OWNER will be withheld until the CONTRACTOR has satisfactorily complied with the foregoing requirements for final cleanup of the project site.

**1.2 CLOSEOUT TIMETABLE**

- A. The CONTRACTOR shall establish dates for pipeline and equipment testing, acceptance periods, and on-site instructional periods (as required under the Contract). Such dates shall be established not less than one week prior to beginning any of the foregoing items, to allow the OWNER and their authorized representative's sufficient time to schedule attendance at such activities.

**1.3 FINAL SUBMITTALS**

- A. The CONTRACTOR, prior to requesting final payment, shall obtain and submit the following items to the OWNER:
1. Written guarantees, where required.
  2. Operating Manuals and instructions, as required
  3. New permanent cylinders and key blanks for all locks
  4. Record Drawings.
  5. Bonds for maintenance, etc., as required.
  6. Certificates of inspection and acceptance by local governing agencies having jurisdiction.
  7. Releases from all parties who are entitled to claims against the subject project, property, or improvement pursuant to the provisions of law, on the OWNER-furnished form or on the CONTRACTOR's standard form as approved by the OWNER.
  8. Releases from property owners where the CONTRACTOR has secured an easement, permit or agreement for use of the property.

**1.4 MAINTENANCE AND GUARANTEE**

- A. The CONTRACTOR shall comply with the maintenance and guarantee requirements contained in the Supplementary General Conditions.
- B. Replacement of earth fill or backfill, where it has settled below the required finish elevations, shall be considered as a part of such required repair work, and any repair or resurfacing constructed by the CONTRACTOR which becomes necessary by reason of such settlement shall likewise be considered as a part of such required repair work unless the CONTRACTOR shall have obtained a statement in writing from the affected private owner or public agency releasing the OWNER from further responsibility in connection with such repair or resurfacing.
- C. The CONTRACTOR shall make all repairs and replacements promptly upon receipt of written order from the OWNER. If the CONTRACTOR fails to make such repairs or replacements promptly, the OWNER reserves the right to do the WORK and the CONTRACTOR and his surety shall be liable to the OWNER for the cost thereof.

**1.5 BOND**

- A. The CONTRACTOR shall provide a bond to guarantee performance of the provisions contained in Paragraph "Maintenance and Guarantee" above, and Section 4.4 of the Supplementary General Conditions.

**PART 2 PRODUCTS (NOT USED)**

**PART 3 EXECUTION (NOT USED)**

**END OF SECTION**

D I V I S I O N 2

---

SITE WORK



**SECTION - 02100  
SITE PREPARATION**

**PART 1 GENERAL**

**1.1 THE REQUIREMENT**

- A. The Work of this section includes measures required during the CONTRACTOR's initial move onto the site to protect existing fences, houses and associated improvements, streets, and utilities near the construction areas from damage and clearing, grubbing and stripping.

**1.2 SITE INSPECTION**

- A. Prior to moving onto the site, the CONTRACTOR shall inspect the Site conditions and review maps of the pipeline routes and facilities delineating the OWNER's property and right-of-way lines.
- B. The OWNER will document existing alignment conditions with video and photo records. These will be available to the CONTRACTOR if requested.

**1.3 COORDINATION OF WORK**

- A. Coordinate all work in this section with Section 02270 – Erosion and Sediment Control. The scheduling and performance of this work is dependent on meeting the requirements of the Erosion Control (EC) section. No ground disturbing activities shall be performed before approved EC measures are implemented for that area to the satisfaction of the OWNER.
- B. Comply with provisions on the Drawings and in Section 01060 – Regulatory Requirements, regarding restrictions on work within wetland areas and general environmental protection measures.

**PART 2 PRODUCTS (NOT USED)**

**PART 3 EXECUTION**

**3.1 SITE ACCESS**

- A. The CONTRACTOR shall develop any necessary access to the pipeline route; including access barriers to prohibit entry of unauthorized persons.
- B. **Utility Interference:** Where existing utilities interfere with the WORK, notify the utility owner and the OWNER before proceeding.

**3.2 CLEARING, GRUBBING, AND STRIPPING**

- A. Construction areas shall be cleared of grass and weeds to at least a depth of six inches and cleared of structures, pavement, sidewalks, concrete or masonry debris, trees, logs, upturned stumps, loose boulders, and any other objectionable material of any kind which would interfere with the performance or completion of the WORK, create a hazard to safety, or impair the subsequent usefulness of the WORK, or obstruct its operation. Pavement, curbs, and sidewalk requiring removal shall be sawcut along neat lines as shown on the plans. Trees and other natural vegetation outside the actual limits of construction shall be protected from damage during construction, as directed by the OWNER.
- B. Within the limits of excavation, the areas below the natural ground surface shall be grubbed to a depth necessary to remove all stumps, roots, buried logs, and all other objectionable material. Septic tanks, drain fields, and connection lines and any other underground structures, debris or waste shall be removed

if found on the Site unless marked for protection by OWNER. All objectionable material from the clearing and grubbing process shall be removed from the Site and wasted in approved safe locations.

- C. In areas not covered with pavement or sidewalks, and outside of wetlands, the topsoil shall be removed to a depth of 6 inches below the stripping limits across the full width of the clearing limits. The stripped materials shall be stockpiled for later incorporation as the final backfill material for the trench and other disturbed areas as shown on the Drawings.
- D. Unless otherwise indicated, native trees larger than three inches in diameter at the base shall not be removed without the OWNER's approval. The removal of any trees, shrubs, fences, or other improvements outside of rights-of-way, if necessary for the CONTRACTOR's choice of means and methods, shall be arranged with the owner of the property, and shall be removed and replaced, at no additional cost to the OWNER.
- E. Backfill all holes and depressions resulting from tree root and stump removals.
  - 1. Use native material
  - 2. Compact by track-walking until no further settlement is noted under equipment weight.
  - 3. Grade to conform to the surrounding ground contours.
- F. Level all soil piles left from stump removal by rough grading.

### **3.3 EROSION CONTROL**

- A. Requirements for erosion control are specified in Section 02270. Coordinate the requirements of this section with Section 02270.

**END OF SECTION**

**SECTION - 02140  
DEWATERING**

**PART 1 GENERAL**

**1.1 THE REQUIREMENT**

- A. The CONTRACTOR shall provide all labor, materials, and equipment necessary to dewater trench and structure excavations, in accordance with the requirements of the Contract Documents.
- B. The CONTRACTOR shall make a judgment of the level of effort required based on his review of the project his own independent investigations and include costs of dewatering all other areas not specifically listed.
- C. The CONTRACTOR shall secure all other necessary permits to complete the requirements of this Section of the Specifications.
- D. The CONTRACTOR shall regularly monitor the quality of the water being pumped and discharged. If the water is determined to be unsuitable for disposal to receiving waters based on code and permit requirements, the CONTRACTOR shall provide appropriate treatment of the water to achieve minimum water quality levels to allow release.
- E. Costs for dewatering shall be included in the unit cost for furnishing and installing the pipe.

**1.2 GENERAL REQUIREMENTS**

- A. Where groundwater is encountered during construction, the CONTRACTOR shall immediately take measures to control the rate of flow into the work area, and quality of water discharged from the work area. The OWNER shall judge the adequacy of the CONTRACTOR's dewatering effort, determine whether construction can continue without violating terms of any permit, and direct a course of action.
- B. Areas of high groundwater may need to be dewatered with deep wells or well points prior to construction. In tight soil areas, where the rate of groundwater infiltration is slow, pumping directly from the trench may be feasible.
- C. Depending on the site, sediment-laden water from trenches shall be settled in temporary storage facilities, such as ponds or Baker Tanks, and only clean water meeting permit requirements shall be discharged to drainage channels.
- D. If the settling process does not adequately remove sediment such that water can be released to receiving waters, the CONTRACTOR shall employ mechanical or chemical treatment to meet water quality discharge requirements prior to release.
- E. To reduce sediment in water pumped directly from trenches, the following measure shall be implemented when site conditions allow.
  - 1. If possible, a depression in the down-gradient portion of the trench shall be excavated to collect water before removal.

**1.3 QUALITY CONTROL**

- A. It shall be the sole responsibility of the CONTRACTOR to control the rate and effect of the dewatering in such a manner as to avoid all objectionable settlement and subsidence.
- B. All dewatering operations shall be adequate to assure the integrity of the finished project and shall be the responsibility of the CONTRACTOR.

- C. The responsibility for conducting the dewatering operation in a manner which will protect adjacent structures and facilities rests solely with the CONTRACTOR. The cost of repairing any damage to adjacent structures and restoration of facilities shall be the responsibility of the CONTRACTOR.
- D. In the event that dewatering is determined to be affecting an adjacent structure, the CONTRACTOR shall cease dewatering until satisfactory methods can be developed so as not to endanger the integrity of the existing facility or structure. If an existing facility or structure is damaged in any way or if the owner of such facility claims damage of any type, the CONTRACTOR shall be solely responsible for correcting the problem to the satisfaction of the owner of that structure or facility.

## **PART 2 PRODUCTS**

### **2.1 EQUIPMENT AND MATERIALS**

- A. Dewatering, where required, may include the use of wells, well points, sump pumps, temporary pipelines for water disposal, rock or gravel placement, and other means. Standby pumping equipment shall be maintained on the jobsite.
- B. If the water produced as a result of dewatering operations is not suitable for direct discharge to receiving waters, the water shall be treated. The CONTRACTOR is responsible for the selection of proper equipment, chemicals and process to successfully treat the water for discharge.

### **2.2 CONTINGENCY EQUIPMENT AND MATERIALS**

- A. The CONTRACTOR shall have onsite, at all times, sufficient pumping equipment to dewater any open sections of trench, in good working condition, with spare pumps and other equipment for emergencies including, but not limited to, power outage. The CONTRACTOR shall have onsite, at all times, competent workers for the operation and repair of the pumping equipment.

## **PART 3 EXECUTION**

### **3.1 GENERAL REQUIREMENTS**

- A. The CONTRACTOR shall provide all equipment necessary for dewatering. It shall have on hand, at all times, sufficient pumping equipment and machinery in good working condition and shall have available, at all times, competent workmen for the operation of the pumping equipment. Adequate standby equipment shall be kept available at all times to insure efficient dewatering and maintenance of dewatering operation during power failure.
- B. Dewatering for structures, pits, and pipelines shall commence when groundwater is first encountered, and shall be continuous until such times as water can be allowed to rise in accordance with the provisions of this Section or other requirements.
- C. At all times, site grading shall promote drainage. Surface runoff shall be diverted from excavations. Water entering the excavation from surface runoff shall be collected in shallow ditches around the perimeter of the excavation, drained to sumps, and be pumped or drained by gravity from the excavation to maintain a bottom free from standing water.
- D. Dewatering shall at all times be conducted in such a manner as to preserve the undisturbed subgrade soils at proposed bottom of excavation. Use of sumps for dewatering is acceptable if undisturbed subgrade soils are maintained. If undisturbed subgrade soils cannot be maintained by this method, then the groundwater table shall be lowered to a level at least 2 feet below the bottom of the excavation by other means. The groundwater table shall be lowered further as required for safety or other reasons.

- E. The groundwater control system shall be designed for continuous, 24-hour operation and shall not be shut down between shifts, on holidays, or weekends, or during work stoppage, without written permission from the OWNER.
- F. The groundwater control system shall be monitored continuously while in operation.
- G. The groundwater control system shall include a means for measuring the quantity of discharge.
- H. The quality and quantity of discharge water from the groundwater control and dewatering system shall be in conformance with all Federal, State, and local laws and regulations.
- I. If foundation soils are disturbed or loosened by the upward seepage of water or an uncontrolled flow of water, the affected areas shall be excavated and replaced with foundation stabilization material at no additional cost to the OWNER.
- J. In general, the CONTRACTOR shall maintain the water level below the bottom of excavation in all work areas where groundwater occurs during excavation construction, backfilling, and up to acceptance.
- K. Flotation shall be prevented by the CONTRACTOR by maintaining a positive and continuous removal of water. The CONTRACTOR shall be fully responsible and liable for all damages which may result from failure to adequately keep excavations dewatered.
- L. Where well points or wells are used, they shall be adequately spaced to provide the necessary dewatering and shall be sandpacked and/or other means used to prevent pumping of fine sands or silts from the subsurface. A continual check by the CONTRACTOR shall be maintained to ensure that the subsurface soil is not being removed by the dewatering operation.

### **3.2 SUMPS**

- A. Open or cased sumps may be used provided they meet the requirements of paragraph 3.1.
- B. Sumps shall be designed and constructed to prevent the removal of native or other soils.

### **3.3 SYSTEM MODIFICATIONS**

- A. If the system does not meet the above requirements as determined by the OWNER, the CONTRACTOR shall modify sumps or wells, add sumps or wells, or install additional alternative systems as needed at no additional cost to the OWNER. If during the course of construction, the system or a part thereof becomes inoperable, it shall be repaired or replaced at no additional cost to the OWNER.

### **3.4 SYSTEM PROTECTION**

- A. Necessary precautions shall be taken, including, but not limited to, marking wells and pipes, protecting pipes at vehicular crossings, and routing vehicular traffic away from dewatering facilities to protect the groundwater control system from damage and ensure continued operation.

### **3.5 DISPOSAL OF WATER**

- A. Pumped water shall be disposed of in such a manner so as not to cause damage to public or private property or adversely impact downstream receiving waters or facilities. Quality of discharge water will comply with all State and local regulations and with requirements of all applicable permits.
- B. Quality of discharge water shall comply with permit requirements specified in Section 01060 – Regulatory Requirements.

- C. The removal of natural, in-place soils during dewatering operations shall be prevented. In order to remove sand and fine sized soil particles before disposal into any drainage system, water shall be filtered or coagulated using an approved method or allowed to settle in a sediment trap designed to meet the requirements of the DOE Stormwater Management Manual for Western Washington. If filtration or coagulation methods are used, they shall be conducted to achieve a minimum of 90 percent reduction in total suspended solids. The OWNER may require submission of test results to a frequency of one per day to demonstrate adequate reduction in total suspended solids. No water shall be released directly to private property without written permission from the owner. Water released into any ditch, swale or water course shall be at such a rate so as to avoid any downstream flooding or channel erosion. The system shall be set up such that after initial development, the quantity and size of soil particles will decrease until no visible soil particles are present in water being pumped at any time after 24 hours from initial pumping.
- D. Pumped water shall not be disposed of in a manner which causes contamination of wells in the vicinity.

### **3.6 TERMINATING DEWATERING**

- A. The pumping equipment shall be operated prior to complete shutdown in a manner that will allow the groundwater level to rise gradually to its static level. The release of groundwater to its static level shall be performed in such a manner as to maintain the undisturbed state of the natural foundation soils, prevent disturbance of compacted backfill and prevent flotation or movement of structures, pipelines, and sewers.
- B. After the groundwater control system is deactivated, all wells, sumps and drains shall be removed and the ground shall be restored to a condition better than or equal to the condition prior to installation of the groundwater control system.
- C. The construction, permitting, and abandonment of all wells used in dewatering systems shall comply with Washington State Department of Ecology requirements (Chapter 173-160 WAC and Chapter 18.104 RCW).

**END OF SECTION**

**SECTION - 02270  
EROSION AND SEDIMENT CONTROL**

**PART 1 GENERAL**

**1.1 WORK INCLUDED**

- A. This section covers the work necessary for Install and Maintain Temporary Erosion Control and Water Pollution Control Measures at all CONTRACTOR work and staging areas.
- B. The CONTRACTOR is be responsible for the preparation and implementation of the Stormwater Pollution Prevention Plan (SWPPP), all temporary erosion and sediment controls, plans, sampling, and reporting, and closeout.
- C. CONTRACTOR shall prepare a Construction Stormwater Pollution Prevention Plan (SWPPP) for the entire project in accordance with the requirements Stormwater Management Manual for Western Washington (SWMMWW).
- D. The CONTRACTOR's SWPPP shall include erosion control plans for staging areas used by the CONTRACTOR that are outside designated work area limits.

**1.2 RELATED SECTIONS**

- A. Division 1
- B. Section 01300 - Contractor Submittals
- C. Section 01560 – Environmental Controls
- D. Section 02100 - Site Preparation.
- E. Section 02140 - Dewatering.
- F. Section 02300 – Earthwork
- G. Section 02700 – Bases, Ballasts, Pavement and Appurtenances
- H. Washington State Department of Ecology – Stormwater Management Manual for Western Washington (SMMWW), current version.

**1.3 GENERAL REQUIREMENTS**

- A. All erosion and sediment control procedures shall conform to the current version of the Washington State Department of Ecology Stormwater Management Manual for Western Washington.
- B. The CONTRACTOR shall designate a person responsible as the Certified Erosion and Sediment Control Lead (CESCL). The CESCL shall hold a current certification with Washington State Department of Ecology or associated training programs as CESCL. The CESCL will have overall responsibility for implementation of the Contractor's SWPPP plan and implementation on site erosion control measures.
- C. The CONTRACTOR shall take all precautions to prevent the silting of streams or water impoundments during construction and to control water pollution during the life of the Contract through the use of sediment traps, silt fences, mulching, covering stored piles of soil and backfill, and other erosion control devices or methods. Also, wherever feasible, natural vegetation should be retained and protected.

- D. CONTRACTOR shall prepare a Construction Stormwater Pollution Prevention Plan required to complete the project. The SWPPP will follow the guidelines set in the DOE Stormwater Management Manual for Western Washington.
- E. CONTRACTOR shall represent, on the drawings, required temporary erosion sediment control BMP measures the Contractor intends to use in the implementation of the SWPPP. The SWPPP should extend to such facilities including, but are not limited to, staging areas, parking areas, truck washing areas, and waste storage/disposal areas.
- F. Perform no ground-disturbing activities on the project, unless specifically authorized in writing by the OWNER, until the temporary erosion control BMP's, required in the SWPPP, are completely in place and functional.
- G. CONTRACTOR shall have back-up equipment readily available in case emergency situations arise. This includes pumps, hoses, backhoes, and bulldozers. In addition, CONTRACTOR shall have a stockpile of extra temporary erosion and sediment control BMP materials such as filter fence, gravel, and crushed rock for emergency situations.
- H. Clean water may be discharged into existing waterways or storm drains if the discharge points are sufficiently protected or into vegetated areas within the construction area if the ground infiltration characteristics are adequate to handle the discharge over the period of pumping, as approved by the CESCL.
- I. Depending on the site, sediment-laden water from trenches shall be dispersed over vegetated areas outside of sensitive area buffers or the sediment shall be settled in temporary storage facilities, and only clean water discharged to drainage channels.

#### **1.4 SUBMITTAL REQUIREMENTS AND PROCEDURES**

- A. Submit in accordance with Section 01300 a SWPPP for the project an erosion and sediment control plan to the OWNER for review. No work may begin before the SWPPP is submitted and reviewed by the OWNER.
- B. Where the Contractor or Owner determine temporary erosion sediment control measures are required, they shall be designed in accordance with the current version of the Washington State Department of Ecology Stormwater Management Manual for Western Washington and all other relevant regulations and design standards.
- C. Plans for Temporary Erosion Sediment Control Measures:
  - 1. The CONTRACTOR shall describe how it intends to construct, inspect, operate, and maintain temporary erosion sediment control BMP measures shown on the Drawings or CONTRACTOR facilities such as stockpile areas or waste disposal sites.
  - 2. The CONTRACTOR may schedule the installation or implementation of BMPs in phases, providing no construction activity, including truck traffic, occurs in a segment with incomplete BMPs in place.
  - 3. The SWPPP shall be coordinated with, and in no way contradict, the progress schedule required in Section 01311.
- D. The CONTRACTOR shall revise and bring the SWPPP up to date whenever the OWNER makes written request for revisions and whenever the CONTRACTOR proposes to change the sequence of work. All revisions shall be coordinated with the current approved progress schedule.
- E. The CONTRACTOR's proposed SWPPP shall include:
  - 1. Scheduling and timing of temporary erosion sediment control BMP installations.
  - 2. Manufacturer's data and detailed plans for the products specified in this section.



3. Plans for diverting, collecting, pumping, and piping surface stormwater runoff, process water and seepage from source to the treatment/disposal facilities. The plan shall include the provisions for operating and maintaining the system during periods of inactivity. The plan shall include:
    - a. Layout and details of the system.
    - b. Flow calculations for stormwater, seepage, and dewatering pump discharge. Sketch of location and sizing calculations for dewatering systems.
    - c. Information on pumps, including flow/head, power (gas, diesel, electric), and placement. See Section 01560 for requirements and restrictions on gas and diesel powered equipment.
  4. Plans for all work not shown on the Drawings, including:
    - a. Additional earthwork proposed by CONTRACTOR.
    - b. Temporary access or haul roads.
    - c. CONTRACTOR-provided waste disposal areas.
    - d. Staging, CONTRACTOR's field office, and parking sites.
    - e. Storage of pipe and other trench materials along the right-of-way.
    - f. Stockpile and material processing areas.
  5. Plans and schedules for operating, inspecting, and maintaining erosion and sediment control measures and equipment.
  6. The name and 24-hour-a-day phone number and alternate contacts for responsible CONTRACTOR personnel.
  7. Plans for site restoration of the following areas:
    - a. Work areas.
    - b. Office and parking areas.
    - c. Waste areas.
    - d. Temporary access roads.
  8. A designated individual who will have primary responsibility for the installation and maintenance of the temporary erosion sediment control measures, as well as a designated group of work personnel who will report to the designated lead.
  9. A description of training that will be provided to all construction personnel to establish the importance of and the mechanics of the temporary erosion control measures on the project, including the individual expectations for following the SWPPP.
  10. A plan for the locations and outlets of dewatering systems shall be required.
- F. Shop Drawings, Samples, and Product Data:
1. Samples of all fabrics.
  2. Manufacturer's data on all products.
  3. Stone filter material gradation.
  4. Riprap gradation.
  5. Rock gradation for check dams.
- G. Submission of SWPPP Plan: All submissions shall meet the requirements of Section 01300.
- H. Prepare a schedule of value earned on which to base payment.

## **1.5 OPERATION AND MAINTENANCE OF BMP FACILITIES AND PRACTICES**

- A. Requirements:
1. The CONTRACTOR shall be directly responsible for the operation and maintenance of all BMP facilities, equipment, and treatment.
  2. Provide to the OWNER the name and emergency phone number of one person who can be contacted on a 24-hour-a-day, 7-day-a-week basis. This person shall have the authority to implement maintenance of erosion sediment control measures.
  3. The CONTRACTOR shall respond with adequate personnel, equipment, and material immediately when notified of an emergency situation.
  4. Adhere to approved schedules for inspection and maintenance.

- B. Noncompliance:
1. After notification by the OWNER, in writing, of noncompliance with the requirements of this section, the OWNER may have the work required to restore compliance performed immediately by OWNER's forces or by such other means as the OWNER may deem necessary.
  2. For the purpose of this section, "compliance" shall be agreed to include all items of work shown in the plans, specifications, the approved SWPPP, and any additional items of work directed by the OWNER to meet the requirements of representatives of other agencies charged with enforcement of these requirements.
  3. Direct and indirect costs incurred by the OWNER attributable to correcting noncompliance with this section shall be paid by the CONTRACTOR. Payment will be deducted by the OWNER from monies due, or to become due, the CONTRACTOR. Such direct or indirect cost shall include, but not be limited to, compensation for additional professional services required, all fines or penalties levied against the OWNER for damages relating to this section, corrections, repair and replacement of damaged work, and compensation for OWNER overhead cost related to these activities.
  4. The rights exercised under the provisions of this section shall not diminish the OWNER's ability to pursue any other avenue for additional remedy of damages with respect to the CONTRACTOR's failure to perform the work as required.

## PART 2 PRODUCTS

### 2.1 SILT FABRIC FENCE

- A. Filter Fabric Type 1: Woven polypropylene, monofilament yarn. The fabric shall be inert to biological degradation and shall be resistant to alkalis and acids found in soils. The base plastic shall contain stabilizers and inhibitors to make the fabric resistant to ultraviolet radiation. Filter Fabric Type 1 shall also meet the following physical properties:

Description	Test	Result
Minimum thickness	ASTM D1777	13 mils
Minimum weight	ASTM D3776	6.5 oz/sy
Grab tensile strength	ASTM D4632	415 lbs x 250 lbs
Mullen burst strength	ASTM D3786	510 psi
Equivalent opening size	ASTM D4751	70-100 U.S. Std Sieve
Permeability (cm/sec)	ASTM D4991	0.015
Permittivity (1/sec)	ASTM D4991	0.2
Water Flow Rate (gpm/sf)	ASTM D4991	20

1. Filter Fabric Type 1 shall be Mirafi 700X Synthetic Industries Erosion 1, or approved equal.
- B. Posts shall be either 2-inch by 4-inch standard grade lumber or steel fence posts. The posts shall be spaced no further apart than 6 feet. Closer spacing may be required if the fabric begins to sag and allow leakage over the top.
- C. Washed gravel for backfilling the trench shall have a minimum diameter of 3/4 inch and a maximum diameter of 1-1/2 inches.

### 2.2 MULCHING

- A. Straw shall be used as the mulching material. The straw shall conform to the requirements in the Stormwater Manual.

**2.3 PLASTIC COVERING**

- A. Plastic covering shall meet the requirements of the ASTM D4397 and have a minimum thickness of 6 mils.

**2.4 PIPE SLOPE DRAIN**

- A. Flexible corrugated high density polyethylene (HDPE) pipe shall be used for the pipe slope drains.
- B. A flared entrance section made of HDPE shall be used at the upstream end of each pipe slope drain. The entrance shall transition to a corrugated HDPE pipe with diameter equal to the diameter of the diversion pipe as shown on the Drawings.
- C. Pipe sections shall be joined using HDPE external split couplers with neoprene gaskets. The external split couplers shall be tightened with plastic locking cable ties or wire ties.

**2.5 CHECK DAMS**

- A. Material for rock check dams shall be 4-inch minus rock spalls.
- B. Material for sandbag check dams shall be approved by the OWNER.
- C. Triangular silt dikes may be used as approved by the OWNER.

**2.6 RIPRAP PROTECTION**

- A. Riprap material used as energy dissipating rock for the outlets of the stormwater diversion pipes shall be quarry spalls conforming to Washington State Department of Transportation (WSDOT) Standard Specification Section 9-13 and meeting the following requirements for grading:

Sieve Size	Percent Passing
8-inch	100
6-inch	40 - 60
2-inch	0 - 10

**2.7 WIRE FABRIC FOR SILT FENCE**

- A. 2-inch x 4-inch mesh, 14 gage, or approved equal.
- B. Hot-dip galvanized, ASTM A392, Class 2.
- C. Height: As shown on Drawings.

**2.8 STONE FILTER OVERFLOW WEIR FOR SEDIMENT TRAP**

- A. As shown on the Drawings.

## **2.9 HOLD DOWNS FOR PLASTIC SHEETING**

- A. As approved by the OWNER.
- B. Hold downs to consist of sandbags secured with 1/4-inch polypropylene rope at 10 feet on center maximum each way.
- C. Anchor rope with 2-inch x 4-inch stake fir, standard or better.

## **2.10 STABILIZED CONSTRUCTION ENTRANCES**

- A. Quarry spalls shall meet the requirements of Section 9-13.6 of the WSDOT Standard Specifications.

## **2.11 STORM DRAIN INLETS**

- A. As shown on the Drawings.

## **PART 3 EXECUTION**

### **3.1 GENERAL**

- A. All construction procedures shall conform to the approved erosion and sediment control plans and the requirements of the respective jurisdictions and as shown on the Drawings.
- B. All excavated materials shall be stockpiled at the CONTRACTOR staging area or at a site designated by the CONTRACTOR and approved by the OWNER.
- C. During the period of October 1 to April 30, any stockpiled material that is left unworked for more than 24 hours shall be protected with plastic covering. In addition, any stock piled material near sensitive areas left unworked for 12 hours during the period May 1 to September 30 shall be protected with plastic.
- D. Stockpiled material shall be covered during rain storms.
- E. During the period of October 1 to April 30, plastic covering shall be placed on bare soil slopes.
- F. Where spoil is placed on the downhill side of the trench, it shall be backsloped to drain toward the trench.
- G. CONTRACTOR shall not side cast, push, sluice or cause foreign, waste, or excavated material to enter surface waters. Materials shall be carefully excavated and moved to an approved spoil or waste area. Provide and maintain erosion and sediment control measures.
- H. Sediment shall be trapped onsite using filter fabric fences, sedimentation ponds, sediment traps, and other appropriate methods.
- I. All erosion and sediment control measures and facilities provided shall be maintained in proper condition so that they will individually and collectively perform the functions for which they were provided. In order to ensure the efficiency and proper maintenance of the measures and facilities, inspections shall be made daily to detect any impairment of the structural stability, adequate capacity or other requisites of the measures and facilities which might impair their effectiveness, and the CONTRACTOR shall take immediate steps to correct any such impairment found to exist.
- J. All erosion and sediment control devices shall be removed immediately after the disturbed areas are brought to their final, completed condition. Removal of erosion sediment control devices shall be approved by the OWNER and/or the jurisdiction.

- K. Runoff, stormwater and wastewater flows shall be controlled and treated during construction to minimize water quality impacts. Runoff from undisturbed areas shall be diverted from areas of construction activity by utilizing existing road drainage ditches and drainage ways as much as possible. Where this is not possible, and as practical, diversion dikes and swales shall be constructed so runoff from undisturbed areas will not be contaminated by construction activity. Construction and grading materials shall not be stored within 50 feet of the Ordinary High Water Level of streams, dry or flowing; and shall not be deposited or stored in or alongside wetlands, wetland buffers, streams, rivers, lakes, or watercourses where the materials can be eroded by high water or storm runoff. The OWNER shall approve all stockpile locations.
- L. Water from runoff, dewatering and process wastewater shall be treated and disposed by dispersing it across vegetated (grassy) areas. The method of disposing of water shall be approved by the OWNER. Water with pollutants will require other disposal methods in accordance with local, State, and Federal law.
- M. Stormwater runoff from disturbed areas within the limits of construction and from CONTRACTOR staging and laydown areas shall be collected and treated before releasing. The extent of erosion and sediment control measures required will depend on the extent of the CONTRACTOR's earthwork and ground cover disturbance and resulting erosion potential. The CONTRACTOR is responsible for meeting specified water quality criteria for all stormwater runoff discharge from construction areas.
- N. The CONTRACTOR shall comply with the water quality criteria stated in the permits if sediment-laden flow from the disturbed area enters any streams.

### **3.2 SILT FENCE**

- A. The silt fabric shall be one piece or continuously sewn to make one piece for the full height of the fence including the portion buried in the toe trench. Care shall be taken not to puncture the fabric during installation. Any damaged area shall be repaired or replaced. All joints shall have a 1.5-foot minimum overlap and shall be made in a manner that will not allow soil materials to pass through the joint. Posts shall be embedded a minimum of 1.5 feet. Minimize disturbance of native soils and vegetation when installing filter fabric fences. Side casting soils on the downhill side will not be allowed. Filter fabric material must be toed in as shown on the Drawings for fences to function. Bury filter fabric using washed gravel as shown on the Drawings. Monitor the condition of the filter fabric fences, remove accumulated sediments and keep the filter fabric fence in good condition. Completely remove all fabric and posts at completion of construction.
- B. Wire Fabric:
  - 1. Install wire fabric for attachment of filter fabric for sediment fence.
  - 2. Secure wire fabric to posts with aluminum alloy wire, minimum 10 gage. Secure at top, middle, and bottom.
  - 3. Bury 4-inch minimum of wire fabric in trench upslope and adjacent to the wood post for the full length.
  - 4. Set posts at 6 feet maximum per Drawings.
  - 5. Wire fabric to extend not more than 24 inches above the ground surface unless otherwise noted on Drawings.

### **3.3 GROUND COVER**

- A. Do not clear any areas until construction is ready to begin. Disturb only the minimum area necessary to accomplish the work. The summer construction season is defined as May 1 to September 30. If construction extends beyond the summer construction season, permanent seeding erosion control measures shall be installed in areas unworked for more than 15 consecutive days. In addition, all disturbed areas shall be covered with plastic sheeting when work has stopped for more than 24 hours. If seasonal cover and erosion control practices have already been placed, plastic sheeting is required during the winter season until plant growth is firmly established. If construction has stopped for more than 15

consecutive days during the summer season, temporary cover measures shall be applied to the affected cleared areas. All temporary measures (Summer and Winter) must be inspected and repaired daily.

- B. Protect all disturbed areas, including cleared, cut, fill, or other areas of reduced plant cover or exposed soil caused by work in this contract from erosion until permanent erosion control measures are established. Protection shall include plastic sheeting, organic or inorganic erosion control matting, riprap, temporary seeding, or straw mulch.
- C. Temporary seeding shall be done in accordance with the provisions of Section 02935. Erosion control matting shall be applied according to the manufacturer's printed instructions and Section 02935. Temporary erosion control measures shall be removed prior to installing permanent seeding erosion control only if the temporary facilities interfere with proper installation of permanent seeding (e.g., plastic on slopes to be seeded).
- D. All work areas that are disturbed shall receive temporary or permanent cover measures. The table and text below lists required cover measures by slope and season.

Season	Slope 3:1 or Flatter
Temporary, May 1 to September 30 (Dry Season)	3,000 lb/acre straw mulch if unworked for more than 15 consecutive days; temporary hydroseed mix if future earthwork delayed more than 30 days.
Temporary, October 1 to April 30 (Wet Season)	Plastic on all slopes and stockpiles, with more than 10 feet of vertical relief, if unworked for more than 24 hours. Permanent measures (except hydroseeding, which must be performed in the next growing season) if unworked for more than 15 consecutive days.
Permanent Measures (After Construction)	Hydroseed. Erosion control matting required at critical steeper areas as indicated on the Drawings.

- 1. Slopes steeper than 3:1 and with more than 10 feet of vertical relief, require erosion control matting, as shown on the Drawings, in addition to the measures in the above table.
- E. Areas receiving temporary treatments other than seeding shall be hydroseeded at the beginning of the following seeding season.
- F. Temporary stockpile slopes shall not exceed 2:1. Stockpiles shall be covered with plastic sheeting.
- G. Plastic covering shall be installed and maintained tightly in place by using sandbags or tires on ropes with a maximum 10-foot grid spacing in all directions. All seams shall be overlapped 12 inches and taped or weighted down for the full length. Plastic covering sheets shall be toed in a minimum of 2 feet at the top of slopes in order to prevent surface water flow beneath the sheets.
- H. Areas requiring mulching will be determined by the OWNER based on weather and site conditions. Mulching techniques and rates shall conform to the 1992 Puget Sound Stormwater Manual and the Washington State Department of Ecology Stormwater Management Manual for the Puget Sound Basin.

### 3.4 FLOW ROUTING

- A. To the extent practical, install filter fabric and construct swales, berms, and ditches as required to route surface water from offsite around the areas disturbed by construction. In locations where the offsite flow must cross the disturbed areas, install temporary culvert pipe as required to convey the water across the disturbed areas.

### **3.5 OTHER EROSION CONTROL MEASURES**

- A. Construction of other erosion control measures, in addition to those detailed in these specifications, shall be in accordance with the current Washington State Department of Ecology Stormwater Manual for Western Washington.

### **3.6 MAINTENANCE DURING CONSTRUCTION**

- A. Inspect all erosion control facilities daily or more frequently if necessary, to ensure that they are in good condition and operating properly. Repair or replace damaged or missing items immediately.
- B. Clean, repair, and replace filter fabric fences, straw bale barriers, stormwater diversion pipe sections, check dams, and rip rap pads as necessary to maintain their effectiveness and proper operation.
- C. Maintain seeded surfaces throughout construction including watering and mowing.
- D. Maintain an inspection report file.
- E. Remove and properly dispose of trapped sediment, debris, trash, and all other material from measures designed to retain sediment.
- F. After excavation and/or grading construct slope protection where required or as instructed by the OWNER.
- G. Construct and replace existing storm drains and inlets as soon as possible or as directed by the OWNER.
- H. Provide necessary ditches, swales and dikes to direct all water towards and into sediment ponds or traps.
- I. Excavate sediment out of basins, catch basins, check dams, and traps when capacity has been reduced by 50 percent or when more than 1 foot of sediment has accumulated.
  - 1. Remove sediment from behind sediment fence to prevent overtopping.
  - 2. Prevent sediments from being flushed to the downstream system during cleaning.
  - 3. Check dams shall be replaced before the pore spaces are filled with sediment.

### **3.7 HEAVY RAIN EVENTS**

- A. During periods of heavy rain storms, as determined by the OWNER, construction work on the pipeline shall be discontinued. The CONTRACTOR's equipment and personnel shall be available to construct and maintain the erosion control facilities.
- B. A "Heavy Rain Event" is defined as a rain storm that, in the opinion of the OWNER, is of sufficient duration and intensity that excavation activities must be stopped, and the personnel and equipment from the excavation work are needed to maintain the erosion control facilities.

### **3.8 SITE RESTORATION**

- A. As soon as practical after completion of a portion of the work, or when a work or waste area is no longer required, commence site restoration and install permanent erosion control measures. Temporary erosion and sedimentation control methods shall be kept in effect until the permanent erosion control is established, and the OWNER approves removal of designated temporary facilities. The time period between clearing/grubbing and final ground restoration shall be no more than 4 months in duration.
- B. All disturbed areas shall be properly cleared of temporary structures, rubbish and waste materials upon completion of the Project.

- C. All designated temporary water diversion and treatment areas or devices shall be removed and the areas restored to a permanent protected condition and drainage configuration after completion of work.
- D. Work, staging, laydown, office and other disturbed areas shall be returned to their original condition. Contaminated material and captured sediment shall be removed from the site and disposed of in an approved location.

**END OF SECTION**



**SECTION - 2300**  
**TRENCHING, BACKFILLING, AND COMPACTING FOR UTILITIES**

**PART 1 GENERAL**

**1.1 SUMMARY**

- A. Section Includes:
  - 1. Excavation, trenching, backfilling and compacting, trench safety, removal of pavement and concrete, and haul and disposal of trench material for all underground utilities.
  
- B. Related Sections include but are not necessarily limited to:
  - 1. Skagit Public Utility District No. 1 General Conditions
  - 2. Division 1 - General Requirements.
  - 3. Section 02100 - Site Preparation.
  - 4. Section 02210 - Controlled Low Strength Material.
  - 5. Section 02515 - Precast Concrete Manholes and Vaults.
  - 6. Section 02700 – Bases, Ballasts, Pavement and Appurtenances
  - 7. Section 15000 – Piping: General
  
- C. No subsurface investigation was performed for this project

**1.2 QUALITY ASSURANCE**

- A. Referenced Standards:
  - 1. ASTM International (ASTM):
    - a. C33, Standard Specification for Concrete Aggregates.
    - b. D1557, Standard Test Methods for Laboratory Compaction Characteristics of Soil Using Modified Effort (56,000 ft-lbf/ft<sup>3</sup> (2,700 kN-m/m<sup>3</sup>)).
    - c. D2487, Standard Classification of Soils for Engineering Purposes (Unified Soil Classification System).
    - d. D4253, Standard Test Methods for Maximum Index Density and Unit Weight of Soils Using a Vibratory Table.
    - e. D4254, Standard Test Methods for Minimum Index Density and Unit Weight of Soils and Calculation of Relative Density.

**1.3 DEFINITIONS**

- A. Excavation for trenches shall be structure excavation in accordance Section 2-09 of the Standard Specifications.
  
- B. Removal of Pavement and Concrete Panels refers to the removal of Bituminous Surface Treatments (BST) and asphalt occurring at the surface, and existing concrete pavement panels overlain with asphalt located at unspecified depth below the existing surface layer and layer of aggregate base.
  
- C. Relative Compaction: The ratio, in percent, of the as-compacted field dry density to the laboratory maximum dry density as determined by ASTM D1557. Corrections for oversize material may be applied to either the as-compacted field dry density or the maximum dry density, as determined by the ENGINEER.
  
- D. Optimum Moisture Content: Determined by the ASTM standard specified to determine the maximum dry density for relative compaction. Field moisture content shall be determined on the basis of the fraction passing the ¾-inch sieve.

- E. Well-Graded: A mixture of particle sizes that has no specific concentration or lack thereof of one or more sizes. Well-graded does not define any numerical value that must be placed on the coefficient of uniformity, coefficient of curvature, or other specific grain size distribution parameters. Well-graded is used to define a material type that, when compacted, produces a strong and relatively incompressible soil mass free from detrimental voids.
- F. Unsuitable Material: The term “Unsuitable Material” refers to (1) in-situ or site soils that are unsuitable as foundation or subgrade materials because of their density, moisture content, organic content, plasticity, or gradation; and (2) soil (onsite or imported) that is not suitable as fill or backfill because it does not meet the requirements of the Specifications.
- G. Imported Material: Material obtained by the CONTRACTOR from sources off the site.

#### **1.4 SUBMITTALS**

- A. Miscellaneous Submittals:
  - 1. Trench safety plan and/or trench shoring drawing including current certification of trench shields (trench boxes) if employed.
  - 2. Haul Routes: Submit planned haul routes for material disposal and importation. Include the planned number and frequency of trips.
  - 3. Copies of reclamation permits or fill permit where surface and trenching materials are being disposed.
  - 4. Backfill material gradation testing.

#### **1.5 IMPORTED MATERIAL ACCEPTANCE**

- A. Tests necessary for the CONTRACTOR to locate an acceptable source of imported material shall be made by the CONTRACTOR. Certification that the material conforms to the Specification requirements along with copies of the test results from a qualified commercial testing laboratory shall be submitted to the OWNER for approval as stated in 1.4.A. All sieve analysis testing shall be at the CONTRACTOR’s sole expense.
- B. No imported materials shall be delivered to the site until the proposed source and materials tests have been accepted by the OWNER.

#### **1.6 PROTECTION OF EXISTING UTILITIES AND STRUCTURES**

- A. Existing Utilities: Protect existing utilities in accordance with Section 1-07.17 of the Standard Specifications.
- B. Existing Mailboxes: Protect existing mailboxes which may include the temporary relocation of mailboxes.
- C. Damage to Existing Improvements: The CONTRACTOR shall be responsible for damage in accordance with Section 1-07.17 of the Standard Specifications.

#### **1.7 BACKFILL AND COMPACTION CONTROL TESTS**

- A. Backfill of all signs, mailboxes, trench excavations and behind walls is incidental to other work under the contract. Material shall be in conformance with the Plans and these specifications.
- B. Laboratory densities will be determined by ASTM D1557, Moisture-Density Relations of Soils and Soil-Aggregate Mixtures. For imported materials (e.g., sand, aggregate backfill), CONTRACTOR shall provide current laboratory density test results and pay for same for each source of backfill material to be used.

- C. Density sampling of backfill placed by the CONTRACTOR will be performed by OWNER.
- D. In-place density will be determined by one or more of the following methods:
  - 1. ASTM D1556, Test for Density of Soil In-place by the sand cone method.
  - 2. ASTM D2167, Test for Density of Soil In-place by the rubber balloon method.
  - 3. ASTM D2922, Test for Density of Soil In-place by the nuclear method.
- E. The CONTRACTOR shall assist with this testing work by leveling small test areas and excavating and shoring test pits when and where designated by the OWNER. Backfill the test areas and test pits after the test is complete at the CONTRACTOR's sole expense. The frequency and location of testing shall be determined solely by the OWNER. The OWNER may test any lift of backfill at any time, location, or elevation.

## **1.8 TYPE OF SURFACE RESTORATION**

- A. Surface restoration and backfill above the pipe zone is indicated on the Drawings. The OWNER reserves the right to modify the use, location, and quantities of the various types of restoration during construction as the OWNER considers to be in the best interest of the OWNER.

## **1.9 SITE CONDITIONS**

- A. Avoid overloading or surcharge a sufficient distance back from edge of excavation to prevent slides or caving.
  - 1. Maintain and trim excavated materials in such manner to be as little inconvenience as possible to public and adjoining property owners.
- B. Provide full access to public and private premises and fire hydrants, at street crossings, sidewalks and other points as designated by OWNER to prevent serious interruption of travel.
- C. Protect and maintain bench marks, monuments or other established points and reference points and if disturbed or destroyed, replace items to full satisfaction of OWNER and controlling agency.
- D. Verify location of existing underground utilities.

## **PART 2 PRODUCTS**

### **2.1 SUITABLE FILL AND BACKFILL MATERIAL REQUIREMENTS**

- A. General:
  - 1. Fill, backfill, and embankment materials shall be suitable processed select clean, fine earth, rock, or sand, free from grass, roots, brush, trash, organic matter, debris, and other deleterious material.
  - 2. Backfill within 6-inches of finish grade between the shoulder edge and Fire Hydrant walls may consist of native backfill upon approval by the Engineer.
- B. Fill and backfill materials to be placed within 6 inches of any structure or pipe shall be free of rocks or unbroken masses of earth materials having a maximum dimension larger than 1-inch.
- C. Suitable Materials: Materials not defined as unsuitable in Article 2.2 below are defined as suitable materials and may be used in fills, backfilling, and embankment construction subject to the indicated limitations. In addition, when acceptable to the OWNER, some of the material listed as unsuitable may be used when thoroughly mixed with suitable material to form a stable composite provided it is capable of being compacted to the specified relative compaction.
- D. See Section 02700-Bases, Ballasts, Pavements, and Appurtenances for additional information regarding backfill aggregate requirements.

## **2.2 UNSUITABLE MATERIAL**

- A. Unsuitable materials include the materials listed below.
  - 1. In-situ or site soils that are unsuitable as foundation or subgrade materials because of their density, moisture content, organic content (including coal), plasticity, or gradation.
  - 2. Soils (onsite or imported) that are not suitable as fill because they cannot be compacted sufficiently to achieve the density specified for the intended use according to the requirements of the Specifications.
  - 3. Materials that contain hazardous or designated waste materials including petroleum hydrocarbons, pesticides, heavy metals, and any material which may be classified as hazardous or toxic according to applicable regulations.

## **2.3 USE OF BACKFILL MATERIAL TYPES**

- A. The CONTRACTOR shall use the types of materials as shown on the Drawings for all required backfill construction hereunder.
- B. Where these Specifications conflict with the requirements of any local agency having jurisdiction or with the requirements of a pipe material manufacturer, the OWNER shall be immediately notified. In case of conflict between types of pipe embedment backfills, the CONTRACTOR shall use the agency-specified backfill material if that material provides a greater degree of structural support to the pipe, as determined by the OWNER. In case of conflict between types of trench or final backfill types, the CONTRACTOR shall use the agency-specified backfill material if that material provides the greater in-place density after compaction.
- C. Backfill types shall be consistent with Section 02700 – Bases, Ballasts, Pavement and Appurtenances.
- D. Engineer Ordered Trench Stabilization material shall consist of Quarry Spalls meeting Section 9-16.3 of the Standard Specifications.

## **2.4 FILTER FABRIC**

- A. Geotextile used for Trench Stabilization shall conform to Section 9-33.1, Table 3, of the Standard Specifications for “Soil Stabilization” fabric.

## **PART 3 EXECUTION**

### **3.1 EXCAVATION - GENERAL**

- A. General: Except when specifically provided to the contrary, excavation shall include the removal of all materials of whatever nature encountered, including all obstructions of any nature that would interfere with the proper execution and completion of the WORK. The removal of said materials shall conform to the lines and grades indicated or ordered. Unless otherwise indicated, the entire construction site shall be stripped of all vegetation and debris, and such material shall be removed from the site prior to performing any excavation or placing any fill. The CONTRACTOR shall furnish, place, and maintain all supports and shoring that may be required for the sides of the excavations. Excavations shall be sloped or otherwise supported in a safe manner in accordance with applicable State safety requirements and the requirements of OSHA Safety and Health Standards for Construction (29CFR1926).
- B. Removal of Bituminous Surface Treatment, Pavement, and/or Concrete Panels to accommodate the new pipe shall be in accordance with the work shown on the plans and detail for Typical Trench Restoration. Work shall be in accordance with Section 2-02.3(3) and shall include haul and disposal of removed pavement.

C. Removal and Exclusion of Water:

1. The CONTRACTOR shall remove and exclude water, including stormwater, groundwater, irrigation water, and wastewater, from all excavations unless specifically stated herein. Dewatering shall conform to Section 02140 – Dewatering. Water shall be removed and excluded until backfilling is complete and all field soils testing has been completed.

### 3.2 PIPELINE AND UTILITY TRENCH EXCAVATION

A. Pothole Existing Utility Location:

1. The CONTRACTOR shall excavate and expose existing utilities where indicated on the Drawings as “depth unknown”. Excavation shall be performed in advance of pipeline laying in order to allow time for resolution of utility conflicts by the OWNER.
2. Data, including dates, locations excavated, sketches and photos, depths to existing ground, and horizontal distances shall be submitted to the OWNER as soon as possible in order to minimize delays.
3. Damage to utilities from excavation activities shall be repaired by the CONTRACTOR at no additional cost to the OWNER.

B. Furnish and Install Adequate Site and Trench Safety Systems in Accordance with RCW 49.17:

1. Install and maintain shoring, sheeting, bracing and sloping necessary to support the sides of the excavation and to prevent any movement that may damage adjacent facilities, delay the work, endanger life and health, or pose a threat to the environment. Conform to the requirements of WISHA and other applicable governmental regulations and agencies.
2. All cribbing, sheeting, and shoring shall be designed by a licensed professional engineer in the State of Washington and meet the requirements of W.A.C. 296-155 (Safety Standards for Construction Work, Part N, Excavation, Trenching, and Shoring).
3. The CONTRACTOR shall familiarize themselves with, and comply with, all other applicable codes, ordinances and statutes, and bear sole responsibility for the penalties imposed for noncompliance.
4. The CONTRACTOR shall be solely responsible for making and maintaining all excavations in a safe manner.
5. Use any combination of shoring and overbreak, tunneling, boring, sliding trench shield, or other method allowed by the applicable local, state, and federal safety codes.
6. Carefully reconsolidate the bedding and side support behind a trench shield prior to placing backfill.
7. Leave in place those portions of cribbing and sheeting extending below the crown elevation of the pipe, unless the bedding and side support can be reconsolidated to the satisfaction of the OWNER.
8. Where removal of sheeting would result in damage to adjacent utilities or other property, the OWNER may order all or a portion of sheeting to be cut off and left in place.
9. Do not use horizontal strutting below the barrel of a pipe.
10. Do not use the pipe as support for trench bracing.
11. Damages resulting from improper shoring and failure to shore shall be the sole responsibility of the CONTRACTOR.

C. Contaminated Soil and/or Water:

1. There are no known locations of soil contamination at the project site. However, contaminated material may exist within the work area.
2. Activities involving contaminated materials, should they be encountered, shall be in accordance with:
  - a. Washington State Department of Health Regulations.
  - b. Federal Resources Conservation and Recovery Act (RCRA), 42 USC, Sections 6901 through 6987.
  - c. Federal Hazardous and Solid Waste Amendments (HSWA), PL 98-616.
  - d. Other codes and regulations related to the scope of work.
3. If contaminated materials are encountered during construction, the CONTRACTOR shall stop work immediately in this area, and shall sufficiently secure the work area such that contaminated materials or potentially contaminated materials are not exposed to public. This shall be accomplished through temporary backfilling, trench plating, covering the exposed areas with plastic sheeting, or other means. The CONTRACTOR shall immediately notify the OWNER of his findings, shall secure the

area, and then shall continue work in another area away from the area in question. The CONTRACTOR shall not continue work in the potentially contaminated area until directed by the OWNER. Stopping work in a potentially contaminated area, and moving to another work area, shall be considered part of the work and no additional payment will be made. Payment for work within contaminated areas will be paid in accordance with that specified later in this section.

4. If contaminated materials are encountered, and if directed by the OWNER, the CONTRACTOR shall prepare a site-specific Health and Safety Plan (HSP), subject to review by the OWNER, which details how the CONTRACTOR intends to protect workers while working in the presence of contaminated soils and groundwater.
  5. The HSP shall be prepared, signed, and stamped by a Certified Industrial Hygienist employed by the CONTRACTOR. The HSP shall be reviewed and signed by the CONTRACTOR and all personnel who will be overseeing work in the contaminated construction zones, including subcontractors.
  6. A copy of the HSP shall be provided to all personnel working in the contaminated areas. All CONTRACTOR personnel performing work in the identified contaminated areas shall be required to read the HSP and shall be required to sign an acknowledgement that he/she has obtained and read a copy of the HSP. No worker shall be allowed in the identified contaminated areas until a copy of his/her signed acknowledgement has been submitted to the OWNER by the CONTRACTOR.
  7. The HSP shall conform to the requirements of all local, state, and federal ordinances, rules, regulations, and guidelines concerning occupational health and safety issues. Included as part of the HSP is the requirement for and the implementation of ongoing monitoring of the project by the CONTRACTOR for contaminated materials. This monitoring shall, at a minimum, include visual observation and odor detection by personnel with appropriate hazardous materials training, including 40 hours of EPA-approved Health and Safety training.
  8. The excavation or exposure of soil within 300 feet of the described locations shall be monitored by the CONTRACTOR for subsurface contamination in compliance by personnel with appropriate hazardous materials training, including 40 hours of EPA-approved Health and Safety training.
  9. Analysis of contamination of soil and water samples will be provided by the OWNER through a certified hazardous waste laboratory using U.S. EPA approved analytical methods.
  10. Implementation of the HSP for the project, beyond the monitoring which is included with the HSP, requires: first, detection of contaminated materials; second, a written request by the CONTRACTOR to the OWNER; and third, approval by the OWNER in writing that the HSP shall be implemented.
  11. Stockpiling of contaminated material will be allowed only at locations approved by the OWNER and shall comply with all regulatory requirements. Unless otherwise indicated on the plans, CONTRACTOR shall provide temporary site or sites for stockpiling, and no stockpiling of contaminated material shall be allowed within or adjacent to the pipeline alignment.
  12. In the event that groundwater contamination is encountered, CONTRACTOR shall comply with all applicable federal, state, and local laws and regulations pertaining to the work performed during the dewatering and disposal of contaminated groundwater.
  13. Payment for furnishing the HSP and for removing, storing, and disposing of contaminated soil and/or groundwater will be made in accordance with an agreed price. If agreement cannot be reached, payment will be made by force account in accordance with Section 7.2 of the Supplementary General Provisions.
- D. Trench Bottom: The bottom of the trench shall be excavated uniformly to the grade of the bottom of the pipe bedding. Excavations for pipe bells shall be made as required.
- E. Open Trench:
1. Except for work in roadways, the maximum amount of open trench permitted in any one location shall be 250 feet, or the length necessary to accommodate the amount of pipe installed in a single day, whichever is greater.
  2. In roadways, the open trench length shall be held to the minimum length necessary for pipe installation.
  3. All trenches shall be fully backfilled at the end of each day or, in lieu thereof, shall be covered by heavy steel plates adequately braced and capable of supporting vehicular traffic in those locations where it is impractical to backfill at the end of each day.

4. The above requirements for backfilling or use of steel plate will be waived in cases where the trench is located further than 100 feet from any traveled roadway or occupied structure. In such cases, however, barricades and warning lights meeting safety requirements shall be provided and maintained.
- F. Over-Excavation: When ordered by the OWNER, trenches shall be over-excavated beyond the depth and/or width shown. Such over-excavation shall be to the dimensions ordered. The trench shall then be backfilled to the grade of the bottom of the pipe bedding. Over-excavation less than 6 inches below the limits on the Drawings shall be done at no increase in cost to the OWNER. When the over-excavation ordered by the OWNER is 6 inches or greater below the limits shown, or wider, additional payment will be made to the CONTRACTOR. Said additional payment will be made under the unit price bid item for over-excavation and trench stabilization material.
- G. Where pipelines are to be installed in embankments, fills, or structure backfills, the fill shall be constructed to a level at least one foot above the top of the pipe before the trench is excavated.
- H. If a moveable trench shield is used during excavation operations, the trench width shall be wider than the shield so that the shield is free to be lifted and then moved horizontally without binding against the trench sidewalls. If the trench walls cave in or slough, the trench shall be excavated as an open excavation with sloped sidewalls or with trench shoring, as indicated and as required by the pipe structural design.

### **3.3 TRENCH STABILIZATION**

- A. When, in the opinion of the OWNER, the existing material in the bottom of the trench is unsuitable for supporting the pipe, excavate below the bottom of the pipe, as shown on the Drawings or as directed by the OWNER.
- B. Install Geotextile across full width of trench and up the trench sides to a height adequate to form a 2-foot-minimum lap of fabric over the installed trench stabilization material.
- C. Backfill the trench to subgrade of pipe base with trench stabilization material specified herein. Place the trench stabilization material over the full width of the trench to the required grade. Compact material to provide a firm, non-yielding surface as approved by the OWNER. Providing a minimum 2-foot lap at seams.
- D. At the CONTRACTOR's option, trench stabilization may be constructed to aid dewatering, at no additional cost to the OWNER.

### **3.4 OVER-EXCAVATION NOT ORDERED OR INDICATED**

- A. Any over-excavation carried below the grade ordered or indicated, shall be backfilled to the required grade with the indicated material and compacted. Such work shall be performed by the CONTRACTOR at no additional cost to the OWNER.

### **3.5 PRESERVATION AND RESTORATION OF ADJACENT LANDSCAPE AND SHOULDER**

- A. Where excavation occurs in landscaped or lawn areas the Contractor shall repair areas damaged through the course of the work to substantially similar condition on completion of the work.
- B. CONTRACTOR shall restore City Roads and shoulders to substantially the same condition as prior to the work, with Crushed Surfacing Top Course meeting City and Washington's specifications, at the CONTRACTOR's expense.

### **3.6 EXCAVATION IN VICINITY OF TREES**

- A. Except where trees are indicated to be removed, trees shall be protected from injury during construction operations. Conform to applicable portions of Section 02100 – Site Preparation regarding tree preservation. No tree roots over 2 inches in diameter shall be cut without express permission of the OWNER. Trees shall be supported during excavation by any means previously reviewed by the OWNER.

### **3.7 BACKFILL - GENERAL**

- A. Backfill shall not be dropped directly upon any structure or pipe. Backfill shall not be placed around or upon any structure until the concrete has attained sufficient strength to withstand the loads imposed.
- B. Backfill shall be placed after all water is removed from the excavation, and the trench sidewalls and bottom have been dried to a moisture content suitable for compaction.
- C. If a moveable trench shield is used during excavation, pipe installation, and backfill operations, the shield shall be moved by lifting the shield free of the trench bottom or backfill and then moving the shield horizontally. The CONTRACTOR shall not drag trench shields along the trench causing damage or displacement to the trench sidewalls, the pipe, or the bedding and backfill.
- D. Immediately prior to placement of imported backfill materials, the bottoms and sidewalls of trenches and structure excavations shall have all loose sloughing, or caving soil and rock materials removed. Trench sidewalls shall consist of excavated surfaces that are in a relatively undisturbed condition before placement of backfill materials.

### **3.8 PLACING AND SPREADING OF BACKFILL MATERIALS**

- A. Backfill materials shall be placed and spread evenly in layers. When compaction is achieved using mechanical equipment, the layers shall be evenly spread so that when compacted, each layer shall not exceed 6 inches in thickness.
- B. During spreading, each layer shall be thoroughly mixed as necessary to promote uniformity of material in each layer. Pipe zone backfill materials shall be spread around the pipe so that when compacted the pipe zone backfill will provide uniform bearing and side support.
- C. Where the backfill material moisture content is below the specified moisture content, water shall be added before or during spreading until the proper moisture content is achieved.
- D. Where the backfill material moisture content is too high to permit the specified degree of compaction the material shall be dried until the moisture content is satisfactory.

### **3.9 COMPACTION OF BACKFILL MATERIALS**

- A. Pipe Bedding: When laying the pipe, not less than six inches of specified bedding shall be provided below the bottom of the pipe. An additional six inches of bedding shall be carefully screeded by means of a template shaped to the outside radius of the pipe to provide firm bearing for the full length of each pipe section except at bell holes. A string and/or laser beam must be used to guide the template.
- B. Pipe Zone Backfill: Backfill up to a minimum 6 inches above the top of pipe shall be specified pipe zone material, which is tamped as specified herein. Backfill shall consist of a minimum of two steps, with the first step consisting of backfill and compaction to the springline, and the second step including backfill and compaction to 6 inches above the top of the pipe.



1. After the pipe has been laid and adjusted to specified line and grade, it shall be carefully cradled. Cradling shall be carried on, on both sides of the pipe simultaneously and thoroughly tamped under and around the pipe to secure a uniform bedding for the lower one-half of the pipe. Great care shall be exercised not to damage the protective coating. Backfilling shall be continued when necessary to prevent movement and/or flotation of the pipe.
  2. After the pipe in the trench has been assembled, the CONTRACTOR shall backfill all bell holes in the same manner as specified for cradling pipe.
  3. The CONTRACTOR shall place a protective covering of pipe zone material not less than 6 inches in thickness to cover the entire upper half of the pipe before the trench is backfilled by mechanical equipment. Conform to Standard Detail for "Typical Trench Section" on the Drawings.
- C. Equipment weighing more than 10,000 pounds shall not be used closer to walls than a horizontal distance equal to the depth of the fill at that time. Hand operated power compaction equipment shall be used where use of heavier equipment is impractical or restricted due to weight limitations.
- D. Compaction Requirements: The following compaction test requirements shall be in accordance with ASTM D1557 - Test Method for Laboratory Compaction Characteristics of Soils Using Modified Effort (56,000 ft - lbf/ft<sup>3</sup>) (2,700 kN-m/m<sup>3</sup>) for fine-grained materials (sand and select trench backfill) materials; and in accordance with ASTM D4253 - Standard Test Method for Maximum Index Density and Unit Weight of Soils Using a Vibratory Table, and D4254 - Standard Test Method for Minimum Index Density and Unit Weight of Soils and Calculation of Relative Density, for coarse materials (4-inch-minus gravel and coarse drain rock). Where agency or utility company requirements govern, the highest compaction standards shall apply.

<b>Location or Use of Fill</b>	<b>Relative Compaction</b>	<b>Moisture Content</b>
Pipe zone backfill	90	Within $\pm 2\%$ of optimum
Trench backfill, beneath paved or gravel areas, and beneath structures	95	Within $\pm 2\%$ of optimum
Trench backfill, not beneath paved or gravel areas or structures	80	Within $\pm 2\%$ of optimum
Backfill around structures	90	Within $\pm 2\%$ of optimum
Backfill beneath structures	95	Within $\pm 2\%$ of optimum
Embankment fill for road	95	Within $\pm 2\%$ of optimum
Embankment supporting pipe	95	Within $\pm 2\%$ of optimum
Roadway Gravel Subbase	95	Within $\pm 2\%$ of optimum
Base course and top course	95	Within $\pm 2\%$ of optimum
Overexcavation Backfill	95	Within $\pm 2\%$ of optimum
Topsoil	Lightly rolled, suitable for seeding	—

### **3.10 DISPOSAL OF EXCESS EXCAVATED MATERIALS**

- A. Excess excavated materials not required or not suitable for backfill or fill material shall be removed from the site. Material may not be placed on the right-of-way other than specifically shown on the grading and drainage plans. Make all arrangements hauling and disposal of the excavated material and conform to the requirements of the local agency having jurisdiction.

### **3.11 TOPSOIL REPLACEMENT**

- A. Upon completion of trench backfill, embankment fills and finished grading, previously stockpiled topsoil shall be placed and spread evenly over the disturbed areas. CONTRACTOR shall not operate vehicles and equipment resulting in compaction of topsoil after placement. All topsoil shall be retained and used on site where regrading occurs. Additional topsoil may need to be imported to provide the required top soil depth.

### **3.12 SURFACE RESTORATION**

- A. Conform to the requirements of Section 02700 - Bases, Ballasts, Pavement and Appurtenances.

### **3.13 FIELD QUALITY CONTROL**

- A. Testing:
  1. Perform in-place moisture-density tests as directed by the Owner.
  2. Perform tests through recognized testing laboratory approved by Owner.
  3. Costs of "Passing" tests paid by Owner.
  4. Perform additional tests as directed until compaction meets or exceeds requirements.
  5. Cost associated with "Failing" tests shall be paid by Contractor.
  6. Reference to Engineer in this section will imply Soils Engineer when employed by Owner and directed by Engineer to undertake necessary inspections as approvals as necessary.
  7. Assure Owner has immediate access for testing of all soils related work.
  8. Ensure excavations are safe for testing personnel.

**END OF SECTION**

**SECTION - 02567**  
**INTERFERING UTILITY PROTECTION**

**PART 1 GENERAL**

**1.1 THE REQUIREMENT**

- A. The CONTRACTOR shall protect and keep in service water pipelines and services, stormwater drains, underground power lines, telephone lines, cable TV lines, fiber optic lines, natural gas lines, oil pipelines and shall perform water main relocations and cutting and replacement of other utilities that interfere with the pipeline alignment, complete and in place, in accordance with the Contract Documents.

**PART 2 PRODUCTS**

**2.1 UTILITY REPLACEMENT PIPING**

- A. Utility lines that are cut or otherwise damaged during installation of the new water pipeline shall be replaced with new pipe of the same type material (e.g. reinforced concrete, ductile iron, copper, etc.) as that removed unless otherwise shown on the Drawings or as otherwise specified herein. New materials shall conform to the requirements of this Section.

**2.2 WATER PIPE**

- A. Pipe materials shall conform to Division 15 of these specifications and shall be compatible with existing pipe materials.

**PART 3 EXECUTION**

**3.1 GENERAL**

- A. The CONTRACTOR shall protect from damage and keep in service private and public utilities encountered during the work. Utilities shall include, but are not limited to, storm drain systems, water distribution systems, electrical distribution systems, telephone, fiberoptics and CATV systems, power lines and appurtenances, natural gas lines, oil pipelines, and similar facilities and systems.
- B. The CONTRACTOR shall, a minimum of 2 working days before an excavation, call the Utilities Underground Location Center at 811. In the case of the high pressure gas pipelines and the oil pipelines that are noted on the drawings, provide a minimum of 10 days advance notice before excavation and crossing of the pipeline.
- C. The right is reserved to the OWNER and the owners of utilities, or their authorized agents, to enter upon the CONTRACTOR's work area for the purpose of making changes, connections, or repairs to their facilities. The CONTRACTOR shall cooperate with forces engaged in this work and shall avoid any unnecessary delay or hindrance to work being performed by other forces.
- D. It shall be the CONTRACTOR's responsibility to make whatever notifications and applications as may be necessary in coordinating utility and CONTRACTOR work. Directly inform individual owners or household residents at least 48 hours in advance of beginning the work to minimize or eliminate inconveniences to the public. Inform owners of work which blocks the use of the property in any way by construction or equipment or which interferes with water or sewer service.
- E. In the event any existing utility lines are cut or otherwise disrupted per requirements of the Work, or unintentionally cut or disrupted, the CONTRACTOR shall coordinate directly with the utility affected to restore service as quickly as possible without delay. CONTRACTOR shall bear all costs associated with

removal and replacement of interfering utilities, which CONTRACTOR intentionally or unintentionally cuts, damages, or disrupts, that are not required to be cut and replaced as part of Work.

### **3.2 LOCATIONS OF UTILITIES**

- A. The locations shown on the Drawings for existing utilities are in accordance with available information obtained, for the most part, without uncovering, measuring or other verification. It is the CONTRACTOR's responsibility to call the Utilities Underground Location Center and make every effort to identify the location of existing utilities before digging. The CONTRACTOR shall make necessary arrangements for removal and replacement or repair of these utilities as necessary to facilitate pipeline construction, and the CONTRACTOR shall bear all related costs.
- B. The locations of the high pressure gas pipelines are shown on the Drawings after consultation with the utility owners, without uncovering, measuring or other verification. Per the notes on the Drawings, it is the CONTRACTOR's responsibility to contact the utility owners 10 days in advance of excavation near the pipeline so a representative can be present.
- C. Attention is directed to the possible existence of other underground facilities, such as below-grade vaults, which are not shown on the Drawings. When the removal and/or relocation of these facilities is necessary to accommodate the Work, the OWNER will provide for this additional work by other forces, or this additional work shall be performed by the CONTRACTOR as extra work pursuant to a Change Order. Notify OWNER if utilities not shown on the Drawings are encountered.
- D. It is anticipated that the CONTRACTOR will encounter water, sewer, and electric utilities (service lines running between street mains and private residences and businesses) during work operations. Records of these utility locations may be incomplete and therefore do not appear on the Drawings and will not be field located by the owning utilities. The locations of these services can usually be ascertained by relative meter location, residence location, or through discussion with various private property owners. It shall be the CONTRACTOR's responsibility to locate and protect these private services from damage.

### **3.3 UTILITY POLE AND GUY WIRE INTERFERENCE**

- A. Where trenching is close to power poles or if guys must be removed temporarily during construction, the CONTRACTOR shall coordinate with PSE to provide temporary supports, as necessary, to support electric power poles during construction. Replace permanent guys in original locations unless directed otherwise by PSE or the OWNER. All costs for temporary supports and guy relocation will be paid for by the OWNER.

### **3.4 INTERFERING WATER SERVICES INTERRUPTIONS AND REPLACEMENT**

- A. Individual water services shall be maintained during construction. The CONTRACTOR shall coordinate with the OWNER to relocate and/or replace the interfering services.

### **3.5 INSTALLATION OF REPLACEMENT UTILITY PIPELINES (IF NECESSARY BECAUSE OF INADVERTENT DAMAGE BY CONTRACTOR OR IF AC WATER MAIN)**

- A. Install replacement storm drains, water lines, and sewer line connections, in accordance with Section 7-08.3 of the Standard Specifications, except that trench excavation, bedding, and backfill shall conform to this Section.
- B. Storm drain replacement shall conform to Section 7-04.3 of the Standard Specifications, except that infiltration / exfiltration testing will not be required.
- C. Waterline replacement shall conform to Section 7-11 of the Standard Specifications, including the requirements of hydrostatic testing and disinfection.

- D. The CONTRACTOR shall provide temporary pumps and piping as required to maintain storm and sanitary sewer flows past reaches of sewers temporarily interrupted by the water transmission main construction.

### **3.6 TRENCH EXCAVATION, BEDDING, AND BACKFILL**

- A. Excavation, bedding and backfill shall conform to Section 02300.
- B. Backfill materials at the location of the utility crossing shall be as specified for the adjacent trench condition identified on the Drawings for the new water transmission main.

### **3.7 MINIMUM CLEARANCES**

- A. Where possible, minimum clearance between the new water transmission main and existing utilities shall be 12 inches. Where grades of existing gravity sewers or storm drains must be maintained, resulting in a clearance of less than 12 inches, notify the OWNER for direction.
- B. Where clearance between the new water transmission main and an existing utility is less than 12 inches a two-inch thick neoprene pad shall be placed between the pipes.

### **3.8 DISSIMILAR PIPE ENDS**

- A. Where cut ends of existing sewer or storm drain pipes will not fit the standard factory integral fitting of the replacement pipe, CONTRACTOR shall join pipe with a factory-fabricated adapter coupling or a rubber sleeve type coupling (Fernco, Calder, or approved equal). Similarly, in the case of waterline replacement, CONTRACTOR shall use an appropriately sized transition coupling.

**END OF SECTION**

**SECTION - 02700**  
**BASES, BALLASTS, PAVEMENT AND APPURTENANCES**

**PART 1 GENERAL**

**1.1 THE REQUIREMENT**

- A. The CONTRACTOR shall furnish aggregates, HMA Class ½-inch, P.G. 64-22, Bituminous Surface Treatment (Seal Coat), and appurtenances or other surfacing as directed by the OWNER, complete and in place, in accordance with the Contract Documents and Plans.
- B. Material placement shall be as designated on the Plans and as described in these or referenced specifications.
- C. Supply and placement of backfill for of all sign posts, mail box supports, trench excavations, bore pit excavations, valves, and hydrant wall is considered incidental work.
- D. Appurtenances include Pavement Markings, Beam Guardrail, Remove and Replace Mailbox, and Remove and Replace Permanent Sign and Post.

**1.2 CONTRACTOR SUBMITTALS**

- A. Submittals shall be in accordance with Section 01300. Include materials testing reports for aggregates and asphalt concrete mixes, and emulsified asphalt for chip seal BST.

**1.3 RELATED SECTIONS**

- A. Public Utility District General Notes
- B. Division 1
- C. Section 02270 – Erosion and Sediment Control
- D. Section 02300 – Trenching, Backfilling, and Compactions for Utilities
- E. Section 04200 – Masonry Units
- F. Division 15 - Mechanical

**1.4 QUALITY ASSURANCE**

- A. Settlement of replaced pavement over trenches within the warranty period shall be considered the result of improper or inadequate compaction of the subbase, base materials, or trench backfill. The CONTRACTOR shall promptly repair all pavement deficiencies noted during the warranty period at the CONTRACTOR's sole expense.

**PART 2 PRODUCTS**

**2.1 TOPSOIL**

- A. Topsoil shall be Topsoil Type B according to WSDOT Standard Specifications Section 9-14. Topsoil required to conduct surface restoration in the vicinity of the Pressure Reducing Valve and where pipelines run through and along vegetated areas, shall be harvested from the immediate area where the improvements are installed.

## **2.2 CRUSHED SURFACING TOP COURSE**

- A. Materials shall conform to Section 9-03.9(3) of the Standard Specifications.

## **2.3 TRENCH BACKFILL**

- A. Bedding shall consist of Gravel Backfill for Pipe Zone Bedding meeting Section 9-03.12(3) of the Standard Specifications with 100% passing the 1 1/2" sieve.
- B. Trench backfill material above the pipe zone shall consist of Bank Run Gravel for Trench Backfill, Section 9-03.14(1) of the Standard Specifications with 100% passing the 3" sieve.

## **2.4 ENGINEER ORDERED TRENCH STABILIZATION MATERIAL**

- A. Material shall consist of Quarry Spalls meeting Section 9-13.6 of the Standard Specifications.

## **2.5 ASPHALT CONCRETE**

- A. Materials shall conform to the requirements of Section 5-04 of the Standard Specifications for the manufacturing, supply, placement, and compaction of HMA Class 1/2-Inch with Performance Graded Binder 64-22, and therein referenced WSDOT Standard Specifications Section 9 material specifications using asphalt binder as indicated on the Drawings.

## **2.6 PAVEMENT MARKING PAINT**

- A. Pavement markings (materials, colors, marking descriptions) shall conform to Section 8-22 of the Standard WSDOT Specifications. Pavement marking paint shall be a product specifically formulated for use on asphalt concrete pavement and shall have a proven record of performance and durability.

# **PART 3 EXECUTION**

## **3.1 SUBGRADE PREPARATION**

- A. The subgrade shall be prepared in accordance with Section 02300, as applicable to roadways. For paved or gravel areas, the surface of the subgrade after compaction shall be hard, uniform, smooth and true to grade and cross-section. Subgrade for pavement shall not vary more than 0.02-foot from the indicated grade and cross section. Subgrade for base material shall not vary more than 0.04-foot from the indicated grade and cross section.

## **3.2 SURFACE RESTORATION – INSTALLATION OF CRUSHED SURFACING MATERIAL**

- A. Install compacted crushed surfacing material as shown on the Drawings and in accordance with Section 02300 and Section 4-04 of the Standard WSDOT Specifications.

## **3.3 SURFACE RESTORATION – INSTALLATION OF ASPHALT CONCRETE PAVEMENT**

- A. Install materials as shown on the Drawings immediately following trench backfill operations, and in accordance with Section 02300, Section 5-04.3(5)E of the Standard WSDOT Specifications, and the following:
  1. Base Course: Install in accordance with Section 4-04 of the Standard WSDOT Specifications.
  2. Asphalt Concrete: Install in accordance with Section 5-04 of the Standard WSDOT Specifications.

### **3.4 TEMPORARY PAVEMENT ALTERNATIVE FOR ASPHALT CONCRETE PAVEMENT AREAS**

- A. In lieu of placing hot mix asphalt concrete, CONTRACTOR may place cold-mix asphalt concrete as a temporary pavement prior to placing final hot-mix pavement. Cold-mix shall be installed immediately following trench backfill operations. Permanent hot-mix pavement shall be installed in place of cold-mix as soon as possible. Until permanent pavement is installed, maintain temporary cold mix to provide a suitable driving surface.
- B. CONTRACTOR shall completely remove temporary pavement material and replace with specified hot-mix asphalt concrete prior to project completion. No additional compensation shall be allowed for temporary paving materials or the placement thereof.

### **3.5 SURFACE SMOOTHNESS**

- A. The completed surface shall meet the tolerances of Section 5-04.3(13) of the Standard WSDOT Specifications. Corrective measures for out-of-compliance work will be taken as specified therein at no expense to the OWNER.
- B. Replacement paving shall match the lines and grades of the adjacent paving. In areas where curb and gutter is to be removed, CONTRACTOR shall contact the OWNER in advance, who will survey the top of curb grades in order to replace this section of roadway to the pre-project lines and grades.

### **3.6 PAVEMENT MARKING**

- A. Replace all pavement markings in kind that are damaged by construction. Pavement markings within the neat line of the project shall be paid by Force Account.
- B. Pavement marking paint shall be applied where pavement paint was removed by construction operations. It shall be applied when the pavement surface is dry and clean, and when the air temperature is above 40 degrees F. All equipment used in the application of pavement marking shall produce stripes and markings of uniform quality with clean and well-defined edges that conform to the details and dimensions of adjacent striping. Drips, overspray, improper markings, and paint material tracked by traffic shall be immediately removed from the pavement surface.
- C. Pavement marking shall conform to Section 8-22 of the Standard WSDOT Specifications.

### **3.7 BEAM GUARDRAIL REMOVAL AND INSTALLATION**

- A. Removal and reinstallation of guard rails shall conform to Section 8-11 of the Standard WSDOT Specifications for Galvanized Rail.

### **3.8 REMOVAL AND REINSTALLATION OF PERMANENT SIGNAGE**

- A. Removal and reinstallation of permanent signage shall conform to Section 8-21 of the Standard WSDOT Specifications.

### **3.9 REMOVAL AND REPLACEMENT OF MAILBOX**

- A. Removal and replacement of mailboxes shall conform to Section 8-18 of the Standard WSDOT Specifications.

### **3.10 REMOVAL OF EXISTING STRUCTURES**

- A. Removal of existing structures as indicated on the Drawings shall conform to Section 2-02 of the Standard WSDOT Specifications.



**3.11 PRESERVATION AND RESTORATION OF ADJACENT LANDSCAPE AND SHOULDER**

- A. Where excavation occurs in landscaped or lawn areas the Contractor shall repair areas damaged through the course of the work to substantially similar condition on completion of the work.
- B. Contractor shall repair County Road shoulders to substantially the same condition as prior to the work with Crushed Surfacing Top Course meeting Skagit County, Washington's specifications, at the Contractor's expense.

**END OF SECTION**

# D I V I S I O N 3

CONCRETE

**SECTION - 03002  
CONCRETE**

**PART 1 GENERAL**

**1.1 SUMMARY**

- A. Section Includes:
  - 1. Cast-in-place concrete and grout.
  
- B. Related Sections include but are not necessarily limited to:
  - 1. Section 03600 - Grout
  - 2. Section 02515 - Precast Manholes and Vaults

**1.2 QUALITY ASSURANCE**

- A. Referenced Standards:
  - 1. American Concrete Institute (ACI):
    - a. 116R, Cement and Concrete Terminology.
    - b. 211.1, Standard Practice for Selecting Proportions for Normal, Heavyweight and Mass Concrete.
    - c. 212.3R, Chemical Admixtures for Concrete.
    - d. 304R, Guide for Measuring, Mixing, Transporting, and Placing Concrete.
    - e. 304.2R, Placing Concrete by Pumping Methods.
    - f. 305R, Hot Weather Concreting.
    - g. 306R, Cold Weather Concreting.
    - h. 318, Building Code Requirements for Structural Concrete.
    - i. 347R, Recommended Practice for Concrete Formwork.
  - 2. ASTM International (ASTM):
    - a. A82, Standard Specification Steel Wire, Plain, for Concrete Reinforcement.
    - b. A185, Standard Specification for Steel Welded Wire Fabric, Plain, for Concrete Reinforcement.
    - c. A615, Standard Specification for Deformed and Plain Billet-Steel Bars for Concrete Reinforcement (Including Supplementary Requirements S1).
    - d. A775, Standard Specification for Epoxy-Coated Reinforcing Steel Bars.
    - e. C31, Standard Practice for Making and Curing Concrete Test Specimens in the Field.
    - f. C33, Standard Specification for Concrete Aggregates.
    - g. C39, Standard Test Method for Compressive Strength of Cylindrical Concrete Specimens.
    - h. C94, Standard Specification for Ready-Mixed Concrete.
    - i. C138, Standard Method of Test for Unit Weight, Yield, and Air Content (Gravimetric) of Concrete.
    - j. C143, Standard Test Method for Slump of Hydraulic Cement Concrete.
    - k. C150, Standard Specification for Portland Cement.
    - l. C157, Standard Test Method for Length Change of Hardened Hydraulic Cement Mortar and Concrete.
    - m. C171, Standard Specification for Sheet Materials for Curing Concrete.
    - n. C172, Standard Practice for Sampling Freshly Mixed Concrete.
    - o. C173, Standard Test Method for Air Content of Freshly Mixed Concrete by the Volumetric Method.
    - p. C231, Standard Test Method for Air Content of Freshly Mixed Concrete by the Pressure Method.
    - q. C260, Standard Specification for Air Entraining Admixtures for Concrete.
    - r. C289, Standard Test Method for Potential Alkali-Silica Reactivity of Aggregates (Chemical Method).
    - s. C309, Standard Specification for Liquid Membrane-Forming Compounds for Curing Concrete.
    - t. C494, Standard Specification for Chemical Admixtures for Concrete.
    - u. C595, Standard Specification for Blended Hydraulic Cements.
    - v. C618, Standard Specification for Coal Fly Ash and Raw or Calcined Natural Pozzolan for Use as a Mineral Admixture in Concrete.

- w. C1315, Standard Specification for Liquid Membrane-Forming Compounds Having Special Properties for Curing and Sealing Concrete.
  - x. D994, Standard Specification for Preformed Expansion Joint Filler for Concrete (Bituminous Type).
  - y. D1056, Standard Specification for Flexible Cellular Materials Sponge or Expanded Rubber.
  - z. D1751, Standard Specification for Preformed Expansion Joint Filler for Concrete Paving and Structural Construction (Nonextruding and Resilient Bituminous Types).
  - aa. E329, Standard Specification for Agencies Engaged in the Testing and/or Inspection of Materials Used in Construction.
3. United States Army Corps of Engineers (COE):
- a. CRD-C572, Polyvinyl Waterstops.

**B. Quality Control:**

- 1. Concrete testing agency:
  - a. Contractor to employ and pay for services of a testing laboratory to:
    - 1) Perform materials evaluation.
    - 2) Design concrete mixes.
  - b. Concrete testing agency to meet requirements of ASTM E329.
- 2. Do not begin concrete production until proposed concrete mix design has been approved by Engineer.
  - a. Approval of concrete mix design by Engineer does not relieve Contractor of his responsibility to provide concrete that meets the requirements of this Specification.
- 3. Adjust concrete mix designs when material characteristics, job conditions, weather, strength test results or other circumstances warrant.
  - a. Do not use revised concrete mixes until submitted to and approved by Engineer.
- 4. Perform structural calculations as required to prove that all portions of the structure in combination with remaining forming and shoring system has sufficient strength to safely support its own weight plus the loads placed thereon.

**C. Qualifications:**

- 1. Ready mixed concrete batch plant certified by National Ready Mixed Concrete Association (NRMCA).
- 2. Formwork, shoring and reshoring for slabs and beams except where cast on ground to be designed by a professional engineer currently registered in the state where the project is located.

**1.3 DEFINITIONS**

**A. Per ACI 116R except as modified herein:**

- 1. Concrete fill: Non-structural concrete.
- 2. Concrete Testing Agency: Testing agency employed to perform materials evaluation, design of concrete mixes or testing of concrete placed during construction.
- 3. Exposed concrete: Exposed to view after construction is complete.
- 4. Indicated: Indicated by Contract Documents.
- 5. Lean concrete: Concrete with low cement content.
- 6. Nonexposed concrete: Not exposed to view after construction is complete.
- 7. Required: Required by Contract Documents.
- 8. Specified strength: Specified compressive strength at 28 days.
- 9. Submitted: Submitted to Engineer.

**1.4 SUBMITTALS**

**A. Shop Drawings:**

- 1. See Section 01300.
- 2. Concrete mix designs proposed for use. Concrete mix design submittal to include the following information:
  - a. Sieve analysis and source of fine and coarse aggregates.
  - b. Test for aggregate organic impurities.

- c. Test for deleterious aggregate per ASTM C289.
  - d. Proportioning of all materials.
  - e. Type of cement with mill certificate for cement.
  - f. Type of fly ash with certificate of conformance to specification requirements.
  - g. Slump.
  - h. Air content.
  - i. Brand, type, ASTM designation, and quantity of each admixture proposed for use.
  - j. 28-day cylinder compressive test results of trial mixes per ACI 318 and as indicated herein.
  - k. Shrinkage test results.
  - l. Standard deviation value for concrete production facility.
3. Product technical data including:
- a. Acknowledgement that products submitted meet requirements of standards referenced.
  - b. Manufacturer's installation instructions.
  - c. Manufacturers and types:
    - 1) Joint fillers.
    - 2) Curing agents.
    - 3) Chemical sealer.
    - 4) Bonding and patching mortar.
    - 5) Construction joint bonding adhesive.
    - 6) Non-shrink grout with cure/seal compound.
    - 7) Waterstops.
4. Reinforcing steel: Show grade, sizes, number, configuration, spacing, location and all fabrication and placement details.
- a. In sufficient detail to permit installation of reinforcing without having to make reference to Contract Drawings.
  - b. Obtain approval of Shop Drawings by Engineer before fabrication.
  - c. Mill certificates.
5. Strength test results of in place concrete including slump, air content and concrete temperature.

## **1.5 DELIVERY, STORAGE, AND HANDLING**

### **A. Storage of Material:**

- 1. Cement and fly ash:
  - a. Store in moistureproof, weathertight enclosures.
  - b. Do not use if caked or lumpy.
- 2. Aggregate:
  - a. Store to prevent segregation and contamination with other sizes or foreign materials.
  - b. Obtain samples for testing from aggregates at point of batching.
  - c. Do not use frozen or partially frozen aggregates.
  - d. Do not use bottom 6 IN of stockpiles in contact with ground.
  - e. Allow sand to drain until moisture content is uniform prior to use.
- 3. Admixtures:
  - a. Protect from contamination, evaporation, freezing, or damage.
  - b. Maintain within temperature range recommended by manufacturer.
  - c. Completely mix solutions and suspensions prior to use.
- 4. Reinforcing steel:
  - a. Support and store all rebars above ground.

### **B. Delivery:**

- 1. Concrete:
  - a. Prepare a delivery ticket for each load for ready-mixed concrete.
  - b. Truck operator shall hand ticket to Owner's Representative at the time of delivery.
  - c. Ticket to show:
    - 1) Mix identification mark.
    - 2) Quantity delivered.
    - 3) Amount of each material in batch.
    - 4) Outdoor temp in the shade.
    - 5) Time at which cement was added.

- 6) Numerical sequence of the delivery.
- 7) Amount of water added.
2. Reinforcing steel:
  - a. Ship to jobsite with attached plastic or metal tags with permanent mark numbers.
  - b. Mark numbers to match Shop Drawing mark number.

## **PART 2 PRODUCTS**

### **2.1 ACCEPTABLE MANUFACTURERS**

- A. Subject to compliance with the Contract Documents, the following manufacturers are acceptable:
  1. Nonshrink, nonmetallic grout:
    - a. Sika "SikaGrout 212."
    - b. Gifford Hill "Supreme Grout."
    - c. Master Builders "Masterflow 713."
  2. Epoxy grout:
    - a. Master Builders "Brutem MPG."
    - b. Euclid Chemical Company, "High Strength Grout."
    - c. Fosroc, "Conbextra EPHF".
  3. Expansion joint fillers:
    - a. Permaglaze Co.
    - b. Rubatex Corp.
    - c. Williams Products, Inc.
  4. Waterstops, PVC:
    - a. Greenstreak Plastic Products, Inc.
    - b. W.R.Meadows, Inc.
    - c. Burke Company.
  5. Form coating:
    - a. Richmond "Rich Cote."
    - b. Industrial Lubricants "Nox-Crete Form Coating."
    - c. Protex "Pro-Cote."
  6. Prefabricated forms:
    - a. Simplex "Industrial Steel Frame Forms."
    - b. Symons "Steel Ply."
    - c. Universal "Uniform."
  7. Chemical sealer:
    - a. L & M Construction Chemicals, Inc.
    - b. Euclid Chemical Co.
    - c. Dayton Superior.

### **2.2 MATERIALS**

- A. Portland Cement: Conform to ASTM C150 Type II
- B. Fly Ash:
  1. ASTM C618, Class F or Class C.
  2. Nonstaining.
  3. Hardened concrete containing fly ash to be uniform light gray color.
  4. **Maximum loss on ignition:** 4 percent.
  5. Compatible with other concrete ingredients.
  6. Obtain proposed fly ash from a source approved by the State Highway Department in the state where the Project is located for use in concrete for bridges.
- C. Admixtures:
  1. Air entraining admixtures: ASTM C260.
  2. Water reducing, retarding, and accelerating admixtures:
    - a. ASTM C494 Type A through E.

- b. Conform to provisions of ACI 212.3R.
  - c. Do not use retarding or accelerating admixtures unless specifically approved in writing by Engineer and at no cost to Owner.
  - d. Follow manufacturer's instructions.
  - e. Use chloride free admixtures only.
3. Maximum total water soluble chloride ion content contributed from all ingredients of concrete including water, aggregates, cementitious materials and admixtures by weight percent of cement:
    - a. 0.10 all concrete.
  4. Do not use calcium chloride.
  5. Pozzolanic admixtures: ASTM C618.
  6. Provide admixtures of same type, manufacturer and quantity as used in establishing required concrete proportions in the mix design.
- D. Water: Potable, clean, free of oils, acids and organic matter.
- E. Aggregates:
1. Normal weight concrete: ASTM C33, except as modified below.
  2. Fine aggregate: Clean natural sand.
    - a. No manufactured or artificial sand.
  3. Coarse aggregate: Crushed rock, natural gravel, or other inert granular material.
    - a. Maximum amount of clay or shale particles: 1 percent.
  4. Gradation of coarse aggregate:
    - a. Lean concrete and concrete topping: Size #7.
    - b. All other concrete: Size #57 or #67.
- F. Concrete Grout:
1. Nonshrink nonmetallic grout:
    - a. Nonmetallic, noncorrosive, nonstaining, premixed with only water to be added.
    - b. Grout to produce a positive but controlled expansion.
    - c. Mass expansion not to be created by gas liberation.
    - d. Minimum compressive strength of nonshrink grout at 28 days: 6500 psi.
  2. Epoxy grout:
    - a. 3-component epoxy resin system.
      - 1) Two liquid epoxy components.
      - 2) One inert aggregate filler component.
    - b. Each component packaged separately for mixing at jobsite.
- G. Reinforcing Steel:
1. Reinforcing bars: ASTM A615, Grade 60.
  2. Welded wire fabric: ASTM A185.
    - a. Minimum yield strength: 60,000 psi.
  3. Column spirals: ASTM A82.
- H. Forms:
1. Prefabricated or job built.
  2. Wood forms:
    - a. New 5/8 or 3/4 IN 5-ply structural plywood of concrete form grade.
    - b. Built-in-place or prefabricated type panel.
    - c. 4 x 8 FT sheets for built-in-place type except where smaller pieces will cover entire area.
    - d. When approved, plywood may be reused.
  3. Metal forms:
    - a. Metal forms excluding aluminum may be used.
    - b. Forms to be tight to prevent leakage, free of rust and straight without dents to provide members of uniform thickness.
  4. Chamfer strips: Clear white pine, surface against concrete planed.
  5. Form ties: Removable end, permanently embedded body type with cones on outer ends not requiring auxiliary spreaders.
    - a. Cone diameter: 3/4 IN minimum to 1 IN maximum.

- b. Embedded portion 1 IN minimum back from concrete face.
  - c. If not provided with threaded ends, constructed for breaking off ends without damage to concrete.
  - d. Provide ties with built-in waterstops at all walls that will be in contact with process liquid during plant operation.
6. Form release: Nonstaining and shall not prevent bonding of future finishes to concrete surface.
- I. Waterstops:
- 1. Plastic: Corp of Engineers Specification CRD-C572.
  - 2. Serrated with center bulb.
  - 3. Thickness: 3/8 IN.
  - 4. Length (general use): 6 IN unless indicated otherwise.
  - 5. Expansion joints:
    - a. Length: 9 IN.
    - b. Center bulb: 1 IN OD x 1/2 IN ID.
  - 6. Provide hog rings or grommets spaced at maximum 12 IN OC along the length of the water stop.
  - 7. Provide factory made waterstop fabrications at all changes of direction, intersections and transitions leaving only straight butt splices for the field.
- J. Chairs, Runners, Bolsters, Spacers, and Hangers:
- 1. Stainless steel, epoxy coated, or plastic coated metal.
    - a. Plastic coated: Rebar support tips in contact with the forms only.
- K. Chemical Floor Sealer:
- 1. Colorless low VOC water-based solution containing acrylic copolymers.
    - a. ASTM C1315, Class B, minimum 30 percent solids.
  - 2. Similar to L & M Construction Chemicals Inc. Dress & Seal WB 30.
- L. Vapor Retarder:
- 1. Vapor transmission not exceeding 0.1 perm.
  - 2. Tear strength: 15 psi.
  - 3. Similar to:
    - a. Alumiseal "Zero Perm".
- M. Membrane Curing Compound: ASTM C309, Type I-D.
- 1. Resin based, dissipates upon exposure to UV light.
  - 2. Curing compound shall not prevent bonding of any future coverings, coatings or finishes.
  - 3. Curing compounds used in water treatment plant construction to be nontoxic and taste and odor free.
- N. Expansion Joint Filler:
- 1. In contact with water or sewage:
    - a. Closed cell neoprene.
    - b. ASTM D1056, Class SC (oil resistant and medium swell) of 2 to 5 psi compression deflection (Grade SCE41).
  - 2. Exterior driveways, curbs and sidewalks:
    - a. Asphalt expansion joint filler.
    - b. ASTM D994.
  - 3. Other use:
    - a. Fiber expansion joint filler.
    - b. ASTM D1751.

## 2.3 CONCRETE MIXES

- A. General:
- 1. All concrete to be ready mixed concrete conforming to ASTM C94.
  - 2. Provide concrete of specified quality capable of being placed without segregation and, when cured, of developing all properties required.



3. All concrete to be normal weight concrete {except where lightweight concrete is indicated on Drawings}.

B. Strength:

1. Provide specified strength and type of concrete for each use in structure(s) as follows:

TYPE	WEIGHT	SPECIFIED STRENGTH*
Concrete fill	Normal weight	3000 psi
Lean concrete	Normal weight	3000 psi
Concrete topping	Normal weight and lightweight	4000 psi
Precast concrete	Normal weight and lightweight	5000 psi
All other general use concrete	Normal weight	4000 psi

\* Minimum 28-day compressive strength.

C. Air Entrainment:

1. Provide air entrainment in all concrete resulting in a total air content percent by volume as follows:

MAX AGGREGATE SIZE	TOTAL AIR CONTENT PERCENT
1 IN or 3/4 IN	5 to 7
1/2 IN	5 1/2 to 8

2. Air content to be measured in accordance with ASTM C231, ASTM C173, or ASTM C138.

D. Slump - 4 IN maximum, 1 IN minimum:

1. Measured at point of discharge of the concrete into the concrete construction member.
2. Concrete of lower than minimum slump may be used provided it can be properly placed and consolidated.
3. Pumped concrete:
  - a. Provide additional water at batch plant to allow for slump loss due to pumping.
  - b. Provide only enough additional water so that slump of concrete at discharge end of pump hose does not exceed maximum slump specified above.
4. Determine slump per ASTM C143.

E. Selection of Proportions:

1. General:
  - a. Proportion ingredients to:
    - 1) Produce proper workability, durability, strength, and other required properties.
    - 2) Prevent segregation and collection of excessive free water on surface.
2. Minimum cement contents and maximum water cement ratios for concrete to be as follows:

SPECIFIED STRENGTH	MINIMUM CEMENT, LB/CY			MAXIMUM WATER CEMENT RATIO BY WEIGHT
	MAXIMUM 1/2	AGGREGATE 3/4	SIZE, IN 1	
3000	---	517	517	0.45
4000	611	611	611	0.45
5000	---	686	665	0.40

3. Substitution of fly ash:
  - a. Maximum of 25 percent by weight of cement at rate of 1 LB fly ash for 1 LB of cement.
4. Sand cement grout:
  - a. Three parts sand.
  - b. One part Portland cement.
  - c. Entrained air: Six percent plus or minus one percent.
  - d. Sufficient water for required workability.

- e. Minimum 28-day compressive strength: 3,000 psi.
  - 5. Pan stair fill:
    - a. Coarse aggregate: 100 percent passing a 1/2 IN sieve.
    - b. Proportions:
      - 1) 1 sack cement.
      - 2) 150 LBS coarse aggregate.
      - 3) 150 LBS fine aggregate (sand).
    - c. Adjust mix to obtain satisfactory finishing.
  - 6. Normal weight concrete:
    - a. Proportion mixture to provide desired characteristics using one of methods described below:
      - 1) Method 1 (Trial Mix): Per ACI 318, Chapter 5, except as modified herein.
        - a) Air content within range specified above.
        - b) Record and report temperature of trial mixes.
        - c) Proportion trial mixes per ACI 211.1.
      - 2) Method 2 (Field Experience): Per ACI 318, Chapter 5, except as modified herein:
        - a) Field test records must be acceptable to Engineer to use this method.
        - b) Test records shall represent materials, proportions and conditions similar to those specified.
  - 7. Required average strength to exceed the specified 28-day compressive strength by the amount determined or calculated in accordance with the requirements of Paragraph 5.3 of ACI 318 using the standard deviation of the proposed concrete production facility as described in Paragraph 5.3.1 of ACI 318.
- F. Allowable Shrinkage: 0.048 percent per ASTM C157.

### **PART 3 EXECUTION**

#### **3.1 FORMING AND PLACING CONCRETE**

- A. Formwork:
  - 1. Contractor is responsible for design and erection of formwork.
  - 2. Construct formwork so that concrete members and structures are of correct size, shape, alignment, elevation and position.
    - a. Allowable tolerances: As recommended in ACI 347R.
  - 3. Provide slabs and beams of minimum indicated depth when sloping foundation base slabs or elevated floor slabs to drains.
    - a. For slabs on grade, slope top of subgrade to provide floor slabs of minimum uniform indicated depth.
    - b. Do not place floor drains through beams.
  - 4. Openings: Provide openings in formwork to accommodate work of other trades.
    - a. Accurately place and securely support items built into forms.
  - 5. Chamfer strips: Place 3/4 IN chamfer strips in forms to produce 3/4 IN wide beveled edges on permanently exposed corners of members.
  - 6. Clean and adjust forms prior to concrete placement.
  - 7. Tighten forms to prevent mortar leakage.
  - 8. Coat form surfaces with form release agents prior to placing reinforcing bars in forms.
- B. Reinforcement:
  - 1. Position, support and secure reinforcement against displacement.
  - 2. Locate and support with chairs, runners, bolsters, spacers and hangers, as required.
  - 3. Set wire ties so ends do not touch forms and are directed into concrete, not toward exposed concrete surfaces.
  - 4. Lap splice lengths: ACI 318 Class B top bar tension splices unless indicated otherwise on the Drawings.
  - 5. Extend reinforcement to within 2 IN of concrete perimeter edges.
    - a. If perimeter edge is earth formed, extend reinforcement to within 3 IN of the edge.
  - 6. Minimum concrete protective covering for reinforcement: As shown on Drawings.

7. Do not weld reinforcing bars.
  8. Welded wire fabric:
    - a. Install welded wire fabric in maximum practical sizes.
    - b. Splice sides and ends with a splice lap length measured between outermost cross wires of each fabric sheet not less than:
      - 1) One spacing of cross wires plus 2 IN.
      - 2) 1.5 x development length.
      - 3) 6 IN.
    - c. Development length: ACI 318 basic development length for the specified fabric yield strength.
- C. Construction, Expansion, and Contraction Joints:
1. Provide at locations indicated.
  2. Locate wall vertical construction joints at 30 FT maximum centers and wall horizontal construction joints at 10 FT maximum centers.
  3. Locate construction joints in floor slabs and foundation base slabs so that concrete placements are approximately square and do not exceed 2500 SF.
  4. Locate construction joints in columns and walls:
    - a. At the underside of beams, girders, haunches, drop panels, column capitals, and at floor panels.
    - b. Haunches, drop panels, and column capitals are considered part of the supported floor or roof and shall be placed monolithically therewith.
    - c. Column based need not be placed monolithically with the floor below.
  5. Locate construction joints in beams and girders:
    - a. At the middle of the span, unless a beam intersects a girder at that point.
    - b. If the middle of the span is at an intersection of a beam and girder, offset the joint in the girder a distance equal to twice the beam width.
    - c. Provide satisfactory means for transferring shear and other forces through the construction joint.
  6. Locate construction joints in suspended slabs:
    - a. At or near the center of span in flat slab or T-beam construction.
    - b. Do not locate a joint between a slab and a concrete beam or girder unless so indicated on Drawings.
  7. In pan-formed joists:
    - a. At or near span center when perpendicular to the joists.
    - b. Centered in the slab, midway between joists, when parallel to the joists.
  8. Install construction joints perpendicular to main reinforcement with all reinforcement continued across construction joints.
  9. At least 48 HRS shall elapse between placing of adjoining concrete construction.
  10. Thoroughly clean and remove all laitance and loose and foreign particles from construction joints.
  11. Before new concrete is placed, coat all construction joints with an approved bonding adhesive used and applied in accordance with manufacturer's instructions.
- D. Embedments:
1. Set and build in anchorage devices and other embedded items required for other work that is attached to, or supported by concrete.
  2. Use setting diagrams, templates and instructions for locating and setting.
  3. Secure waterstops in correct position using hog rings or grommets spaced along the length of the waterstop and wire tie to adjacent reinforcing steel.
- E. Placing Concrete:
1. Place concrete in compliance with ACI 304R and ACI 304.2R.
  2. Place in a continuous operation within planned joints or sections.
  3. Begin placement when work of other trades affecting concrete is completed.
  4. Place concrete by methods which prevent aggregate segregation.
  5. Do not allow concrete to free fall more than 4 FT.
  6. Where free fall of concrete will exceed 4 FT, place concrete by means of tremie pipe or chute.
- F. Consolidation:
1. Consolidate all concrete using mechanical vibrators supplemented with hand rodding and tamping, so that concrete is worked around reinforcement and embedded items into all parts of forms.

G. Protection:

1. Protect concrete from physical damage or reduced strength due to weather extremes.
2. In cold weather comply with ACI 306R except as modified herein.
  - a. Do not place concrete on frozen ground or in contact with forms or reinforcing bars coated with frost, ice or snow.
  - b. Minimum concrete temperature at the time of mixing:

OUTDOOR TEMPERATURE AT PLACEMENT (IN SHADE)	CONCRETE TEMPERATURE AT MIXING
Below 30 DegF	70 DegF
Between 30-45 DegF	60 DegF
Above 45 DegF	50 DegF

- c. Do not place heated concrete that is warmer than 80 DegF.
  - d. If freezing temperatures are expected during curing, maintain the concrete temperature at or above 50 DegF for 7 days or 70 DegF for 3 days.
  - e. Do not allow concrete to cool suddenly.
3. In hot weather comply with ACI 305R except as modified herein.
  - a. At air temperature of 90 DegF and above, keep concrete as cool as possible during placement and curing.
  - b. Do not allow concrete temperature to exceed 90 DegF at placement.
  - c. Prevent plastic shrinkage cracking due to rapid evaporation of moisture.
  - d. Do not place concrete when the actual or anticipated evaporation rate equals or exceeds 0.2 LBS/SF/HR as determined from ACI 305R, Figure 2.1.5.

H. Curing:

1. Begin curing concrete as soon as free water has disappeared from exposed surfaces.
2. Cure concrete by use of moisture retaining cover, burlap kept continuously wet or by membrane curing compound.
3. Provide protection as required to prevent damage to concrete and to prevent moisture loss from concrete during curing period.
4. Provide curing for minimum of 7 days.
5. Form materials left in place may be considered as curing materials for surfaces in contact with the form materials except in periods of hot weather.
6. In hot weather follow curing procedures outlined in ACI 305R.
7. In cold weather follow curing procedures outlined in ACI 306R.
8. If forms are removed before 7 days have elapsed, finish curing of formed surfaces by one of above methods for the remainder of the curing period.
9. Curing vertical surfaces with a curing compound: Cover vertical surfaces with a minimum of two coats of the curing compound.
  - a. Allow the preceding coat to completely dry prior to applying the next coat.
  - b. Apply the first coat of curing compound immediately after form removal.
  - c. Vertical surface at the time of receiving the first coat shall be damp with no free water on the surface.
  - d. A vertical surface is defined as any surface steeper than 1 vertical to 4 horizontal.

I. Form Removal:

1. Remove forms after concrete has hardened sufficiently to resist damage from removal operations or lack of support.
2. Where no reshoring is planned, leave forms and shoring used to support concrete until it has reached its specified 28-day compressive strength.
3. Where reshoring is planned, supporting formwork may be removed when concrete has sufficient strength to safely support its own weight and loads placed thereon.
  - a. While reshoring is underway, no superimposed loads shall be permitted on the new construction.
  - b. Place reshores as soon as practicable after stripping operations are complete but in no case later than the end of working day on which stripping occurs.
  - c. Tighten reshores to carry their required loads.

- d. Leave reshores in place until concrete being supported has reached its specified 28-day compressive strength.

### 3.2 CONCRETE FINISHES

#### A. Tolerances:

1. Class A: 1/8 IN in 10 FT.
2. Class B: 1/4 IN in 10 FT.

#### B. Surfaces Exposed to View:

1. Provide a smooth finish for exposed concrete surfaces and surfaces that are:
  - a. To be covered with a coating or covering material applied directly to concrete.
  - b. Scheduled for grout cleaned finish.
2. Remove fins and projections, and patch voids, air pockets, and honeycomb areas with cement grout.
3. Fill tie holes with nonshrink nonmetallic grout.

#### C. Surfaces Not Exposed to View:

1. Patch voids, air pockets and honeycomb areas with cement grout.
2. Fill tie holes with nonshrink nonmetallic grout.

#### D. Grout Cleaned Finish:

1. Mix one part Portland cement and 1-1/2 parts fine sand with sufficient bonding agent/water mixture to produce a grout with the consistency of thick paint.
  - a. White Portland cement shall be substituted for gray Portland cement to produce a color that matches color of surrounding concrete as determined by trial patch for areas not to be painted.
2. Wet surface of concrete to prevent absorption of water by grout and uniformly apply grout with brushes or spray gun.
3. Immediately scrub the surface with a cork float or stone to coat and fill air bubbles and holes.
4. While grout is still plastic, remove all excess grout by working surface with rubber float, sack or other approved means.
5. After the surface whitens from drying, rub vigorously with clean burlap.
6. Keep final finish damp for a minimum of 36 HRS after final rubbing.

#### E. Slab Float Finish:

1. After concrete has been placed, consolidated, struck off, and leveled, do no further work until ready for floating.
2. Begin floating when water sheen has disappeared and surface has stiffened sufficiently to permit operation.
3. During or after first floating, check planeness of entire surface with a 10 FT straightedge applied at not less than two different angles.
4. Cut down all high spots and fill all low spots during this procedure to produce a surface within Class B tolerance throughout.
5. Refloat slab immediately to a uniform sandy texture.

#### F. Troweled Finish:

1. Float finish surface.
2. Next power trowel, and finally hand trowel.
3. Produce a smooth surface which is relatively free of defects with first hand troweling.
4. Perform additional trowelings by hand after surface has hardened sufficiently.
5. Final trowel when a ringing sound is produced as trowel is moved over surface.
6. Thoroughly consolidate surface by hand troweling.
7. Leave finished surface essentially free of trowel marks, uniform in texture and appearance and plane to a Class A tolerance.
8. On surfaces intended to support floor coverings remove any defects of sufficient magnitude that would show through floor covering by grinding.

#### G. Broom Finish: Immediately after concrete has received a float finish as specified, give it a transverse scored texture by drawing a broom across surface.

- H. Apply chemical floor hardener to permanently exposed interior concrete floor slab surfaces where indicated.
  - 1. Apply in accordance with manufacturer's instructions.

### **3.3 GROUT**

- A. Preparation:
  - 1. Nonshrinking nonmetallic grout:
    - a. Clean concrete surface to receive grout.
    - b. Saturate concrete with water for 24 HRS prior to grouting.
  - 2. Rock anchors:
    - a. Clean rock anchors of all loose material.
    - b. Orient hook or bends in anchor bars to clear anchor bolts, reinforcements, and other embedments to be installed later.
  - 3. Epoxy grout: Apply only to clean, dry, sound surface.
- B. Application:
  - 1. Nonshrinking nonmetallic grout:
    - a. Mix in a mechanical mixer.
    - b. Use no more water than necessary to produce flowable grout.
    - c. Place in accordance with manufacturer's instructions.
    - d. Completely fill all spaces and cavities below the bottom of baseplates.
    - e. Provide forms where baseplates and bedplates do not confine grout.
    - f. Where exposed to view, finish grout edges smooth.
    - g. Except where a slope is indicated on Drawings, finish edges flush at the baseplate, bedplate, member, or piece of equipment.
    - h. Protect against rapid moisture loss by covering with wet rags or polyethylene sheets.
    - i. Wet cure grout for 7 days, minimum.
  - 2. Rock anchors:
    - a. See Item 1 above.
    - b. If rodded:
      - 1) Fill each hole so that it overflows when anchor bar is inserted.
      - 2) Force anchor bars into place.
    - c. If pressure placed, set anchor bar before grouting.
    - d. Take special care to avoid any movement of anchors that have been placed.
  - 3. Epoxy grout:
    - a. Mix and place in accordance with manufacturer's instructions.
    - b. Completely fill all cavities and spaces around dowels and anchors without voids.
    - c. Obtain manufacturer's field technical assistance as required to ensure proper placement.

### **3.4 FIELD QUALITY CONTROL**

- A. Owner will employ and pay for services of a concrete testing laboratory to perform testing of concrete placed during construction.
  - 1. Contractor to cooperate with Owner in obtaining and testing samples.
- B. Tests During Construction:
  - 1. Strength test - procedure:
    - a. Three cylinders, 6 IN DIA x 12 IN high, will be taken from each sample per ASTM C172 and ASTM C31.
    - b. Cylinders will be tested per ASTM C39:
      - 1) One at 7 days.
      - 2) Two at 28 days.
  - 2. Strength test - frequency:
    - a. Not less than one test each day concrete placed.
    - b. Not less than one test for each 50 CY or major fraction thereof placed in one day.
    - c. Not less than one test for each type of concrete poured.
    - d. Not less than one test for each concrete structure exceeding 2 CY volume.

3. Slump test: Per ASTM C143.
    - a. Determined for each strength test sample.
    - b. Additional slump tests may be taken.
  4. Air content: Per ASTM C231, ASTM C173, and ASTM C138.
    - a. Determined for each strength test sample.
  5. Temperature: Determined for each strength test sample.
- C. Evaluation of Tests:
1. Strength test results: Average of 28-day strength of two cylinders from each sample.
    - a. If one cylinder manifests evidence of improper sampling, molding, handling, curing or testings, strength of remaining cylinder will be test result.
    - b. If both cylinders show any of above defects, test will be discarded.
- D. Acceptance of Concrete:
1. Strength level of each type of concrete shall be considered satisfactory if both of the following requirements are met:
    - a. Average of all sets of three consecutive strength tests equals or exceeds the required specified 28-day compressive strength.
    - b. No individual strength test falls below the required specified 28-day compressive strength by more than 500 psi.
  2. If tests fail to indicate satisfactory strength level, perform additional tests and/or corrective measures as directed by Engineer.
    - a. Perform additional tests and/or corrective measures at no additional cost to Owner.

### 3.5 SCHEDULES

- A. Form Types:
1. Surfaces exposed to view:
    - a. Prefabricated or job-built wood forms.
    - b. Laid out in a regular and uniform pattern with long dimensions vertical and joints aligned.
    - c. Produce finished surfaces free from offsets, ridges, waves, and concave or convex areas.
    - d. Construct forms sufficiently tight to prevent leakage of mortar.
  2. Surfaces normally submerged or not normally exposed to view:
    - a. Wood or steel forms sufficiently tight to prevent leakage of mortar.
  3. Other types of forms may be used:
    - a. For surfaces not restricted to plywood or lined forms.
    - b. As backing for form lining.
- B. Grout:
1. Nonshrinking nonmetallic grout: General use.
  2. Epoxy grout:
    - a. Grouting of dowels and anchor bolts into existing concrete.
    - b. Other uses indicated on Drawings.
  3. Sand cement grout: Keyways of precast members.
- C. Concrete:
1. Precast concrete: Where indicated on Drawings.
  2. Lean concrete: Where indicated on Drawings.
  3. Concrete fill: Where indicated on Drawings.
  4. Lightweight concrete: Where indicated on Drawings.
  5. Normal weight concrete: All concrete.
  6. Concrete pan fill: Stair and landings where indicated on Drawings.
  7. General use concrete: All other locations.
- D. Concrete Finishes:
1. Grout cleaned finish: Where indicated on Drawings.
  2. Slab finishes:
    - a. Use following finishes as applicable, unless otherwise indicated:

- 1) Floated finish: Surfaces intended to receive roofing, concrete topping, lean concrete, concrete fill and waterproofing.
- 2) Troweled finish: Interior floor slabs, exposed roof slabs and base slabs of structures, equipment bases, and column bases.
- 3) Broom finish: Sidewalks, docks, concrete stairs, and ramps.

**END OF SECTION**



D I V I S I O N 5

METALS

**SECTION - 05500**  
**MISCELLANEOUS METALWORK AND CASTINGS**

**PART 1 GENERAL**

**1.1 THE REQUIREMENT**

- A. The CONTRACTOR shall provide miscellaneous metalwork and appurtenances, complete and in place, in accordance with the Contract Documents.

**1.2 REFERENCE SPECIFICATIONS, CODES, AND STANDARDS**

**A. Federal Specifications:**

- MIL-G-18015 A (3) (Ships) Aluminum Planks. (6063-T6)  
MIL-A-907E Antiseize Thread Compound, High Temperature

**B. Commercial Standards:**

- AA-M32C22A41 Aluminum Assn.  
AASHTO HS-20 Truck Loading  
AISC Manual of Steel Construction  
AISI Design of Light Gauge, Cold-Formed Steel Structural Members  
ASTM A36 Carbon Structural Steel  
ASTM A48 Gray Iron Castings  
ASTM A53 Pipe, Steel, Black and Hot-Dipped, Zinc-Coated, Welded and Seamless  
ASTM A123 Zinc (Hot-Dip Galvanized) Coatings on Iron and Steel Products  
ASTM A153 Zinc Coating (Hot-Dip) on Iron and Steel Hardware  
ASTM A193 Alloy Steel and Stainless Steel Bolting Materials for High Temperature Service  
ASTM A194 Carbon and Alloy Steel Nuts for Bolts for High Pressure and High Temperature Service  
  
ASTM A307 Carbon Steel Bolts and Studs, 60,000 psi Tensile Strength  
ASTM A325 Structural Bolts, Steel, Heat Treated, 120/105 ksi Minimum Tensile Strength  
ASTM A500 Cold-Formed Welded and Seamless Carbon Steel Structural Tubing in Rounds and Shapes  
  
ANSI/AWS D1.1 Structural Welding Code - Steel  
ANSI/AWS D1.2 Structural Welding Code - Aluminum  
ANSI/AWS QC1 Qualification and Certification of Welding Inspectors

**1.3 CONTRACTOR SUBMITTALS**

- A. **Shop Drawings:** Shop Drawings of all miscellaneous metalwork shall be submitted in accordance with Section 01300.
- B. An ICBO report listing the ultimate load capacity in tension and shear for each size and type of concrete anchor shall be submitted. CONTRACTOR shall submit manufacturer's recommended installation instructions and procedures for adhesive anchors. Upon review, by OWNER, these instructions shall be followed specifically.
- C. No substitution for the indicated adhesive anchors will be considered unless accompanied with ICBO report verifying strength and material equivalency, including temperature at which load capacity is reduced to 90 percent of that determined at 75 degrees F.

## PART 2 PRODUCTS

### 2.1 GENERAL REQUIREMENTS

- A. **Steel:**
  - 1. **Shapes, Plates, Bars:** ASTM A36.
  - 2. **Pipe Columns, Bollards:** ASTM A53, Type E or S, Grade B standard weight unless noted otherwise.
  - 3. **Tubes:** ASTM A500 Grade B.
- B. **Corrosion Protection:** Unless otherwise indicated, fabricated steel metalwork shall be hot-dip galvanized after fabrication.
- C. **Stainless Steel:** Unless otherwise indicated, stainless steel metalwork and bolts shall be of Type 316 stainless steel.
- D. **Aluminum:** Unless otherwise indicated, aluminum metalwork shall be of Alloy 6061-T6. Aluminum in contact with concrete, masonry, wood, porous materials, or dissimilar metals shall have contact surfaces coated with two coats of bituminous coating, total thickness 8 mils.
- E. **Cast Iron:** Unless otherwise indicated, iron castings shall conform to the requirements of ASTM A48, Class 50B or better.

### 2.2 VAULT HATCHES

- A. Where access hatches are mounted in a vault slab or on a concrete curb, the hatch shall be a flush type as indicated herein.
- B. Hatches shall be fabricated from 1/4" aluminum, unless otherwise indicated. Hatch hardware shall be Type 316 stainless steel. Hatches shall be gutter-type; Bilco Type "J-AL" or approved equal.
- C. Hatch opening sizes, number and swing direction of door leaves, and locations, shall be as indicated. Sizes are for the clear opening.
- D. **Performance Characteristics:**
  - 1. Cover(s) shall be reinforced to support a minimum AASHTO HS-20 live load with a maximum deflection of 1/150th of the span.
  - 2. Operation of the cover shall be smooth and easy with controlled operation throughout the entire arc of opening and closing.
  - 3. Entire door, including all hardware components, shall be highly corrosion resistant.
  - 4. Operation of cover shall not be affected by temperature.
- E. **Cover:** Shall be 1/4-inch (6.3-mm) diamond pattern aluminum.
- F. **Channel Frame:** Shall be 1/4-inch (6.3-mm) extruded aluminum with bend down anchor tabs around the perimeter and have a minimum cross-sectional area of 7.0 square inches for proper drainage. A continuous EPDM gasket shall be mechanically attached to the aluminum frame to create a barrier around the entire perimeter of the cover and significantly reduce the amount of dirt and debris that may enter the channel frame.
- G. **Hinges:** Shall be specifically designed for horizontal installation and shall be through bolted to the cover and frame with tamperproof Type 316 stainless fasteners.
- H. **Drain Coupling:** Provide a 1-1/2-inch (38-mm) drain coupling located as shown on the Drawings.

- I. **Lifting Mechanisms:** Manufacturer shall provide the required number and size of compression spring operators enclosed in telescopic tubes to provide smooth, easy, and controlled cover operation throughout the entire arc of opening and to act as a check in retarding downward motion of the cover when closing. The upper tube shall be the outer tube to prevent accumulation of moisture, grit, and debris inside the lower tube assembly. The lower tube shall interlock with a support bracket welded to a formed 1/4-inch gusset support plate.
- J. A removable exterior turn/lift handle with a spring-loaded ball detent shall be provided to open the cover, and the latch release shall be protected by a flush, gasketed, removable screw plug.
- K. **Hardware:**
  - 1. Heavy forged aluminum hinges, each having a minimum 1/4-inch (6.3-mm) diameter Type 316 stainless steel pin, shall be provided and shall pivot so the cover does not protrude into the channel frame.
  - 2. Cover(s) shall be equipped with a hold-open arm which automatically locks the cover in the open position.
  - 3. Cover(s) shall be fitted with the required number and size of compression spring operators. Springs shall have an electrocoated acrylic finish. Spring tubes shall be constructed of a reinforced nylon 6/6 based engineered composite material.
  - 4. A Type 316 stainless steel snap lock with fixed handle shall be mounted on the underside of the cover.
  - 5. Provide locking device for padlock.
- L. **Finishes:** Factory finish shall be mill finish aluminum with bituminous coating applied to the exterior of the frame.

## 2.3 BOLTS AND ANCHORS

- A. **Standard Service (Non-Corrosive Application):** Unless otherwise indicated, bolts, anchor bolts, washers, and nuts shall be steel as indicated herein. Threads on galvanized bolts and nuts shall be formed with suitable taps and dies such that they retain their normal clearance after hot-dip galvanizing. Except as otherwise indicated, steel for bolts, anchor bolts and cap screws shall be in accordance with the following:
  - 1. **Structural Connections:** ASTM A307, Grade A or B, hot-dip galvanized.
  - 2. **Anchor Bolts:** ASTM A307, Grade A or B, or ASTM A36.
  - 3. **High Strength Bolts Where Indicated:** ASTM A325
  - 4. **Pipe and Equipment Flanges:** ASTM A193, Grade B-7
- B. **Corrosive Service:** All bolts, nuts, and washers in the locations listed below shall be ASTM A325 Type 3 (corten steel) unfinished, with nuts to ASTM A563C3 or A563DH3 and washers to ASTM F436-1.
  - 1. All buried locations.
  - 2. All chemical handling areas.
  - 3. Inside trenches, containment walls, and curbed areas.
  - 4. Locations indicated by the Contract Documents or designated by the OWNER to be provided with stainless steel bolts.
- C. Unless otherwise indicated, stainless steel bolts, anchor bolts, nuts, and washers shall be Type 316 stainless steel, class 2, conforming to ASTM A193 for bolts and to ASTM A194 for nuts. All threads on stainless steel bolts shall be protected with an anti-seize lubricant suitable for submerged stainless steel bolts, to meet government specification MIL-A-907E. Buried bolts in poorly drained soil shall be coated the same as the buried pipe.
  - 1. Antiseize lubricant shall be classified as acceptable for potable water use by the NSF.
  - 2. Antiseize lubricant shall be "PURE WHITE" by Anti-Seize Technology, Franklin Park, IL, 60131; AS-470 by Dixon Ticonderoga Company, Lakehurst, NJ, 08733, or approved equal.

**D. Bolt Requirements:**

1. The bolt and nut material shall be free-cutting steel.
2. The nuts shall be capable of developing the full strength of the bolts. Threads shall be Coarse Thread Series conforming to the requirements of the American Standard for Screw Threads. All bolts and cap screws shall have hexagon heads and nuts shall be Heavy Hexagon Series.
3. Bolts and nuts shall be installed with washers fabricated of material matching the base material of bolts, except that hardened washers for high strength bolts shall conform to the requirements of the AISC Specification. Lock washers fabricated of material matching the bolts shall be installed with washers where indicated.
4. The length of each bolt shall be such that after the joint is made up, the bolt extends through the entire nut, but in no case more than 1/2-inch beyond the nut.

**E. Sleeve Anchors:**

**1. Manufacturers and Products:**

- a. ITW Ramset/Red Head, Wood Dale, IL; Dynabolt Hex Nut Sleeve Anchor.
- b. Powers Rawl, New Rochelle, NY; Hex Head Power-Bolt Anchor.
- c. Simpson Strong-Tie Co., Inc., Pleasanton, CA; Sleeve-All Hex Head Anchor.
- d. Wej-It Corp., Tulsa, OK; Wej-It Sleeve Anchor.

**F. Adhesive Anchors:** Unless otherwise indicated, all drilled, concrete or masonry anchors shall be adhesive anchors. No substitutions will be considered unless accompanied with ICBO report verifying strength and material equivalency.

**1. Threaded Rod:**

- a. ASTM F593 stainless steel threaded rod, diameter as shown on Drawings.
- b. Length as required, to provide minimum depth of embedment.
- c. Clean and free of grease, oil, or other deleterious material.
- d. For hollow-unit masonry, provide galvanized or stainless steel wire cloth screen tube to fit threaded rod.

**2. Adhesive:**

- a. Two-component, designed to be used in adverse freeze/thaw environments, with gray color after mixing.
- b. Cure Temperature, Pot Life, and Workability: Compatible for intended use and environmental conditions.
- c. Nonsag, with selected viscosity base on installation temperature and overhead application where applicable.

**3. Packaging and Storage:**

- a. Disposable, self-contained cartridge system capable of dispensing both components in the proper mixing ratio and fitting into a manually or pneumatically operated caulking gun.
- b. Store adhesive cartridges on pallets or shelving in covered storage area, in accordance with manufacturer's written instructions.
- c. Cartridge Markings: Include manufacturer's name, product name, material type, batch or serial number, and adhesive expiration date.
- d. Dispose of cartridges if shelf life has expired.

**4. Manufacturers and Products:**

- a. ITW Ramset/Red Head, Wood Dale, IL; Epcon Ceramic 6 Epoxy or A7 Adhesive Anchor System. (Use only Epcon A7 Adhesive System for hollow masonry.)
- b. Hilti, Inc., Tulsa, OK; HIT Doweling Anchor System, HIT HY 150 (HIT HY 20 for hollow masonry).
- c. Powers Rawl, New Rochelle, NY; Power Fast Epoxy Injection Gel Cartridge System.
- d. Simpson Strong-Tie Co., Inc., Pleasanton, CA; Epoxy-Tie Adhesive ET or Acrylic-Tie Adhesive. (Use only Acrylic-Tie Adhesive for temperatures below 40 degrees F.)
- e. Covert Operations, Inc., Long Beach, CA; CIA-Gel 7000 Epoxy Anchors.
- f. U.S. Anchor, Pompano Beach, FL; Ultrabond 1.
- g. Unitex, Kansas City, MO; Pro-Poxy 300 and Pro-Poxy 300 Fast Epoxy Adhesive Anchors.

## **PART 3 EXECUTION**

### **3.1 FABRICATION AND INSTALLATION REQUIREMENTS**

- A. **Fabrication and Erection:** Except as otherwise indicated, the fabrication and erection of structural steel shall conform to the requirements of the American Institute of Steel Construction "Manual of Steel Construction."

### **3.2 WELDING**

- A. **Method:** Welding shall be by the metal-arc method or gas-shielded arc method as described in the American Welding Society's "Welding Handbook" as supplemented by other pertinent standards of the AWS. Qualification of welders shall be in accordance with the AWS Standards governing same.
- B. **Quality:** In assembly and during welding, the component parts shall be adequately clamped, supported and restrained to minimize distortion and for control of dimensions. Weld reinforcement shall be as indicated by the AWS Code. Upon completion of welding, weld splatter, flux, slag, and burrs left by attachments shall be removed. Welds shall be repaired to produce a workmanlike appearance, with uniform weld contours and dimensions. All sharp corners of material which is to be painted or coated shall be ground to a minimum of 1/32-inch on the flat.

### **3.3 GALVANIZING**

- A. Structural steel plates shapes, bars, and fabricated assemblies required to be galvanized shall, after the steel has been thoroughly cleaned of rust and scale, be galvanized in accordance with the requirements of ASTM A123. Any galvanized part that becomes warped during the galvanizing operation shall be straightened. Bolts, anchor bolts, nuts and similar threaded fasteners, after being properly cleaned, shall be galvanized in accordance with the requirements of ASTM A153. Field repairs to galvanizing shall be made using "Galvinox," "Galvo-Weld," or approved equal.

### **3.4 DRILLED ANCHORS**

- A. Drilled anchors and reinforcing bars shall be installed in strict accordance with the manufacturer's instructions. Holes shall be roughened with a brush on a power drill, cleaned and dry. Drilled anchors shall not be installed until the concrete has reached the required 28-day compressive strength. Adhesive anchors shall not be loaded until the adhesive has reached its indicated strength in accordance with the manufacturer's instructions.

**END OF SECTION**

D I V I S I O N 1 5

MECHANICAL

**SECTION - 15001  
PIPING: GENERAL**

**PART 1 GENERAL**

**1.1 THE REQUIREMENT**

- A. The CONTRACTOR shall supply and install the piping systems, complete and operable, as indicated on the Plan and Profile drawings, in accordance with the Contract Documents.
- B. The Contractor shall provide fabrication and layout drawings for all piping systems. It is the CONTRACTOR's responsibility to construct the piping system according to the fabrication drawings for a complete and functional system.
- C. The mechanical or Plan and Profile drawings define the general layout, configuration, routing, method of support, pipe size, and pipe type. These drawings are not pipe construction or fabrication drawings. It is the CONTRACTOR's responsibility to develop the details necessary to construct the mechanical piping systems to accommodate the specific equipment provided, and to provide and install all spools, spacers, adapters, and connectors for a complete and functional system.
- D. The provisions of this Section shall apply to all piping sections in Division 15.

**1.2 CONTRACTOR SUBMITTALS**

- A. **General:** Submittals shall be furnished in accordance with Section 01300.
- B. **Shop Drawings:** Shop Drawings for the piping system that are within the CONTRACTOR's scope of supply and responsibility shall contain the following information:
  - 1. **Drawings:** Layout drawings including all necessary dimensions, details, pipe joints, fittings, specials, valves, appurtenances, anchors, guides, and material lists. Fabrication drawings shall indicate all spool pieces, spacers, adapters, connectors, fittings, and supports to accommodate the equipment and valves in a complete and functional system.
- C. **Samples:** All expenses incurred in making samples for certification of tests shall be borne by the CONTRACTOR at no increase in cost to the OWNER.
- D. **Certifications:**
  - 1. All necessary certificates, test reports, and affidavits of compliance shall be obtained by the CONTRACTOR.
  - 2. **Fabricator Statement:** A statement from the pipe fabricator certifying that all pipes will be fabricated subject to a recognized Quality Control Program. An outline of the program shall be submitted to the OWNER for review prior to the fabrication of any pipe.
- E. **Bolting Torque for Gaskets:** Provide bolting torques from gasket supplier for proper seating of flange gaskets for each size and pressure rating required.
- F. **Product Technical Data Including:**
  - 1. Copies of manufacturer's written directions regarding material handling, delivery, storage, and installation.
  - 2. Separate schedule sheet for each piping system scheduled in this Section showing compliance of all system components. Attach technical product data on gaskets, pipe fittings, and other components.
- G. **Miscellaneous Submittals:**
  - 1. Test reports:
    - a. Copies of pressure test results on all piping systems.
    - b. Notification of time and date of piping pressure tests.



## PART 2 PRODUCTS

### 2.1 GENERAL

- A. **Extent of Work:** All pipes, fittings, and appurtenances shall be provided in accordance with the requirements of the applicable Sections of Division 15 and as indicated.
- B. **Pipe Supports:** All pipes shall be adequately supported, as indicated in the drawings.
- C. **Lining:** Application, thickness, and curing of pipe lining shall be in accordance with the requirements of the applicable Sections of Division 15, unless otherwise indicated.
- D. **Coating:** Application, thickness, and curing of pipe coating shall be in accordance with the requirements of the applicable Sections of Division 15, unless otherwise indicated. Pipes above ground or in structures shall be shop-primed and field-coated.
- E. **Pressure Rating:** All piping systems shall be designed for the maximum expected pressure as defined in the applicable Sections of Division 15.
- F. **Inspection:** All pipe may be subject to inspection at the place of manufacture. During the manufacture of the pipe, the OWNER shall be given access to all areas where manufacturing is in progress and shall be permitted to make all inspections necessary to confirm compliance with requirements.
- G. **Tests:** Except where otherwise indicated, all materials used in the manufacture of the pipe shall be tested in accordance with the applicable specifications and standards. Welds shall be tested as indicated. The CONTRACTOR shall perform all tests at no additional cost to the OWNER.

### 2.2 DUCTILE IRON PIPE FLANGES

- A. **Flanges:** Flanges for ductile iron piping shall conform to AWWA C207 Class E. Flanges shall have flat faces and shall be attached with bolt holes straddling the vertical axis of the pipe unless otherwise shown. Attachment of the flanges to the pipe shall conform to the applicable requirements of ANSI/AWWA C207. Flanges for miscellaneous small pipes shall be in accordance with the standards specified for these pipes.
- B. **Blind Flanges:** Blind flanges shall be in accordance with ANSI/AWWA C207, or with the standards for miscellaneous small pipes. All blind flanges for pipe sizes 12 inches and over shall be provided with lifting eyes in the form of welded eye bolts.
- C. **Flange Coating:** All machined faces of metal blind flanges and pipe flanges shall be coated with a temporary rust-inhibitive coating to protect the metal until the installation is completed.
- D. **Flange Bolts:** Studs and bolts shall extend through the nuts a minimum of 1/4-inch. All-thread studs shall be used on all valve flange connections, where space restrictions preclude the use of regular bolts.
- E. **Insulating Flanges:** Insulated flanges shall have bolt holes 1/4-inch diameter greater than the bolt diameter.
- F. **Flange Gaskets:** Gaskets for flanged joints shall be full-faced 1/8 inch thick, styrene butadiene (SBR)-Gaskets. Nitrile butadiene rubber (NBR) gaskets may be requested at specific locations as an alternate to SBR. All gaskets must conform to ANSI/AWWA C111.

### 2.3 THREADED INSULATING CONNECTIONS

- A. **General:** Threaded insulating bushings, unions, or couplings, as appropriate, shall be used for joining threaded pipes of dissimilar metals and for piping systems where corrosion control and cathodic protection are involved.
- B. **Materials:** Threaded insulating connections shall be of nylon, Teflon, polycarbonate, polyethylene, or other non-conductive materials, and shall have ratings and properties to suit the service and loading conditions.

### 2.4 MECHANICAL-TYPE COUPLINGS (GROOVED OR BANDED PIPE)

- A. **General:** Cast mechanical-type couplings shall be provided where indicated. The couplings shall conform to the requirements of ANSI/AWWA C606 - Grooved and Shouldered Joints. Bolts and nuts shall conform to the requirements of Section 05500. All gaskets for mechanical-type couplings shall be compatible with the piping service and fluid utilized, in accordance with the coupling Manufacturer's recommendations. The wall thickness of all grooved piping shall conform with the coupling manufacturer's recommendations to suit the highest expected pressure. All mechanical-type couplings on buried piping shall be bonded. The CONTRACTOR shall have the coupling Manufacturer's service representative verify the correct choice and application of all couplings and gaskets, and the workmanship, to assure a correct installation.

### 2.5 SLEEVE-TYPE COUPLINGS

- A. **Construction:** Sleeve-type couplings shall be provided where indicated, in accordance with ANSI/AWWA C219 - Standard for Bolted Sleeve-Type Couplings for Plain-End Pipe, and shall be of steel with steel bolts, without pipe stop, and be of sizes to fit the pipe and fittings indicated. Sleeve couplings shall be rated for 200 psi working pressure and 285 psi transient pressure. Couplings shall be hydraulically tested per AWWA C219. The middle ring shall be not less than 1/4-inch in thickness and shall be either 5 or 7 inches long for sizes up to and including 30 inches and 10 inches long for sizes greater than 30 inches, for standard steel couplings, and 16 inches long for long-sleeve couplings. The followers shall be single-piece contoured mill sections welded and cold-expanded as required for the middle rings and of sufficient strength to accommodate the number of bolts necessary to obtain adequate gasket pressures without excessive rolling. The shape of the follower shall be of such design as to provide positive confinement of the gasket. Bolts and nuts shall conform to the requirements of Section 05500. Buried sleeve-type couplings shall be epoxy-coated at the factory as indicated.
- B. **Pipe Preparation:** The ends of the pipe where indicated, shall be prepared for flexible steel couplings. Plain ends for use with couplings shall be smooth and round for a distance of 12 inches from the ends of the pipe, with outside diameter not more than 1/64-inch smaller than the nominal outside diameter of the pipe. The middle ring shall be tested by cold-expanding a minimum of one percent beyond the yield point, to proof-test the weld to the strength of the parent metal. The weld of the middle ring shall be subjected to air test for porosity.
- C. **Gaskets:** Gaskets for sleeve-type couplings shall be rubber-compound material that will not deteriorate from age or exposure to air under normal storage or use conditions.
  - 1. The rubber in the gasket shall meet the following specifications:
    - a. Color: Jet Black.
    - b. Surface: Non-blooming.
    - c. Durometer Hardness: 74 ± 5.
    - d. Tensile Strength: 1,000 psi minimum.
    - e. Elongation: 175 percent minimum.
  - 2. The gaskets shall be immune to attack by impurities normally found in water or wastewater. All gaskets shall meet the requirements of ASTM D 2000 - Classification System for Rubber Products in Automotive Applications, AA709Z, meeting Suffix B13 Grade 3, except as noted above. All gaskets shall be compatible with the piping service and fluid utilized.

- D. **Insulating Couplings:** Where insulating couplings are required, both ends of the coupling shall have a wedge-shaped gasket which assembles over a rubber sleeve of an insulating compound in order to obtain insulation of all coupling metal parts from the pipe.
- E. **Restrained Joints:** All sleeve-type couplings on pressure lines shall be harnessed unless thrust restraint is provided by other means. Harnesses shall be in accordance with the appropriate reference standard, or as indicated.
- F. **Manufacturers, or approved equal:**
  - 1. Ford Meter Box Co., Inc., Style FUR-C-8-I
  - 2. Smith-Blair, Inc.
  - 3. RieberLok
  - 4. Romac
  - 5. StarGrip Series 4000

## 2.6 FLANGED COUPLING ADAPTERS

- A. **Flange Couplings Adaptors:** Shall conform to requirements for sleeve type couplings as applicable, shall meet ANSI/AWWA C219 and shall be hydrostatically tested.
- B. **Body:** Shall be made of either ductile iron per ASTM A536 or steel per ASTM A53 or ASTM A512 to match the adjoining pipe material. Bolt circle, bolt size and spacing shall conform to the drilling pattern of an ANSI/ASME B16.1 Class 125 drilling. Body shall be rated for 200 psi working pressure and 285 psi transient pressure.
- C. **Follower:** Follower shall be ductile iron per ASTM A536 for sizes 3-12 inches. For sizes 14-inch and greater, follower shall be heavy rolled steel per AISI C1018.
- D. **Gasket:** Grade 30 – standard – specially compounded rubber of all new materials with ingredients to produce superior storage characteristics, permanence and resistance to set after installation. Recommended for water, salt solutions, mild acids and bases.
- E. **Bolts and Nuts:** All bolts used shall be ASTM A325 Type 3 (corten steel) unfinished, with nuts to ASTM A563C3 or A563DH3 and washers to ASTM F436-1. All bolts, nuts and washers used in exposed or above ground locations shall be ASTM/A307, hot-dip galvanized.
- F. **Painting:** Finish shall be enamel with an epoxy coating.
- G. Manufacturers, or approved equal:
  - 1. Smith-Blair, Inc.
  - 2. Romac

## 2.7 EXPANSION JOINTS

- A. Expansion joints shall be Guardian “200” FEP-Lined Expansion Joints by Garlock or approved equal.

## 2.8 PIPE THREADS

- A. All pipe threads shall be in accordance with ANSI/ASME B1.20.1 - Pipe Threads, General Purpose (inch), made up with Teflon tape, unless otherwise indicated.

## 2.9 STAINLESS STEEL PIPE AND FITTINGS (2 INCHES AND SMALLER)

- A. Stainless steel pipe shall be Schedule 40S, ASTM A312/A312M, Type 316 seamless, pickled and passivated. Joints shall be threaded. Fittings shall be threaded forged: 1,000 CWP, ASTM A1 82/A1 82M, Grade F316L. Thread lubricant shall be Teflon tape.

## PART 3 EXECUTION

### 3.1 MATERIAL DELIVERY, STORAGE, AND PROTECTION

- A. All piping materials, fittings, valves, and accessories shall be delivered in a clean and undamaged condition and stored off the ground for protection against oxidation caused by ground contact. All defective or damaged materials shall be replaced with new materials.

### 3.2 GENERAL

- A. All pipes, fittings, and appurtenances shall be installed in accordance with the requirements of the applicable Sections of Divisions 2 and 15.
- B. **Lined Piping Systems:** The lining manufacturer shall take full responsibility for the complete, final product and its application. All pipe ends and joints of lined pipes at screwed flanges shall be epoxy-coated to assure continuous protection.
- C. **Core Drilling:** Where core drilling is required for pipes passing through existing concrete, core drilling locations shall be determined by radiograph of concrete construction to avoid damage to embedded raceways and rebar.
- D. **Cleanup:** After completion of the work, all remaining pipe cuttings, joining and wrapping materials, and other scattered debris, shall be removed from the site. The entire piping system shall be handed over in a clean and functional condition.
- E. **Testing and Disinfection:** Pipelines shall be tested and disinfected in accordance with Section 15960.

### 3.3 WALL AND SLAB PENETRATIONS

- A. Provide sleeves for piping penetrations through aboveground masonry and concrete walls, floors, ceilings, roofs, pilasters, columns, piers, and beams unless specified or otherwise indicated on the Drawings.
- B. For piping 1 inch in nominal diameter and larger, provide sleeves with minimum inside diameters of 1 inch plus outside diameter of piping. For piping smaller than 1 inch in nominal diameter, provide sleeve of minimum twice the outside diameter of piping.
  - 1. Arrange sleeves and adjacent joints so piping can be pulled out of sleeves and replaced without disturbing the structure.
  - 2. Cut ends of sleeves flush with surfaces of concrete, masonry, or plaster.
  - 3. Conceal ends of sleeves with escutcheons where piping runs through floors, walls, or ceilings of finished spaces within buildings.
  - 4. Seal spaces between pipes and sleeves with link-type seals when not otherwise specified or indicated on the Drawings.
  - 5. Seal openings around piping running through interior walls and floors of chlorine rooms and chlorine storage rooms gastight with synthetic rubber sealing compound.
- C. Cast couplings or wall pieces in walls for penetrations of buried rigid piping including cast iron, ductile iron, reinforced concrete, and vitrified clay through structures.
  - 1. Provide couplings or wall pieces with mechanical push-ons, or similar flexible joints at outside faces of walls.

2. Provide additional similar joints in piping at transition points between trenches and structure excavations.
  3. For steel piping, single joints may be used in lieu of 2 joints. Locate single joints outside within 2 feet from outside faces of walls. Link Seal: Use 2 link seals where seal is used to seal at wet wall sleeves. Mount one seal on the inside face of the wall and the other on the outside face of the wall. Coordinate the inside diameter of the wall sleeve with the size of the seal to provide watertight sealing.
- D. Where not indicated on the Drawings, penetrations for conditions other than those specified under the preceding subparagraphs shall be 1 of the 3 types specified in such subparagraphs found by Owner to be the most suitable for the particular conditions.

### **3.4 EXPOSED PIPING**

- A. Install exposed piping in straight runs parallel to the axes of structures, unless indicated otherwise.
1. Install piping runs plumb and level, unless otherwise indicated on the Drawings. Slope plumbing drain piping with 1/8 inch per foot downward in the direction of flow.
- B. In addition to the joints indicated on the Drawings, provide unions, flexible couplings, flanged joints, and other types of joints or means which are compatible with and suitable for the piping system, and necessary to allow ready assembly and disassembly of the piping.
- C. Assemble piping without distortion or stresses caused by misalignment.
1. Match and properly orient flanges, unions, flexible couplings, and other connections.
  2. Do not subject piping to bending or other undue stresses when fitting piping. Do not correct defective orientation or alignment by distorting flanged joints or subjecting flange bolts to bending or other undue stresses.
  3. Flange bolts, union halves, flexible connectors, and other connection elements shall slip freely into place.
  4. Alter piping assembly to fit when proper fit is not obtained.
  5. Install eccentric reducers or increasers with the top horizontal for pump suction piping.

### **3.5 BURIED PIPING**

- A. Bury piping with minimum 3-foot cover without air traps, unless otherwise indicated on the Drawings.
- B. Laying Piping:
1. Lay piping in finished trenches free from water or debris. Begin at the lowest point with bell ends up slope.
  2. Place piping with top or bottom markings with markings in proper position.
  3. Lay piping on an unyielding foundation with uniform bearing under the full length of barrels.
  4. Where joints require external grouting, banding, or pointing, provide space under and immediately in front of the bell end of each section laid with sufficient shape and size for grouting, banding, or pointing of joints.
  5. At the end of each day's construction, plug open ends of piping temporarily to prevent entrance of debris or animals.

### **3.6 EQUIPMENT DRAINAGE AND MISCELLANEOUS PIPING:**

- A. Provide drip pans and piping at equipment where condensation may occur.
- B. Hard pipe stuffing box leakage to nearest floor drain.
- C. Avoid piping over electrical components such as motor control centers, panel boards, etc.
1. If piping must be so routed, utilize 16 GA, 316 stainless steel drip pan under piping and over full length of electrical equipment.

- 2. Hard pipe drainage to nearest floor drain.
- D. Collect system condensation at drip pockets, traps and blow off valves.
- E. Provide drainage for process piping at locations shown on Drawings in accordance with Drawing details.
- F. For applications defined above and for other miscellaneous piping which is not addressed by a specific piping service category in PART 1, provide 304 stainless steel piping and fittings. Size to handle application with  $\frac{3}{4}$  IN being minimum size provided.

**END OF SECTION**

**SECTION - 15062**  
**PIPE: DUCTILE - IRON**

**PART 1 GENERAL**

**1.1 SUMMARY**

- A. Section Includes:
  - 1. Ductile iron piping, fittings, and appurtenances.
  - 2. Polyethylene Encasement for ductile iron pipe.
  
- B. Related Sections include but are not necessarily limited to:
  - 1. Skagit PUD No. 1 General Conditions.
  - 2. Division 1 - General Requirements.
  - 3. Fittings and Hydrants.
  - 4. Galvanic Anode Cathodic Protection (Bonding).

**1.2 QUALITY ASSURANCE**

- A. Referenced Standards:
  - 1. American National Standards Institute (ANSI).
    - a. B1.1, Unified Inch Screw Threads (UN and UNR Thread Form).
    - b. B16.1, Cast-Iron Pipe Flanges and Flanged Fittings, Class 25, 125, 250, and 800.
    - c. B16.21, Nonmetallic Flat Gaskets for Pipe Flanges.
  - 2. ASTM International (ASTM):
    - a. A183, Carbon Steel Track Bolts.
    - b. A193, Standard Specification for Alloy-Steel and Stainless Steel Bolting Materials for High-Temperature Service.
    - c. A194, Standard Specification for Carbon and Alloy Steel Nuts for Bolts for High-Pressure and High-Temperature Service.
    - d. A307, Standard Specification for Carbon Steel Bolts and Studs, 60,000 psi Tensile Strength.
    - e. B695, Standard Specification for Coatings of Zinc Mechanically Deposited on Iron and Steel.
    - f. C150, Specification for Portland Cement.
    - g. D1330, Rubber Sheet Gaskets.
  - 3. American Water Works Association (AWWA):
    - a. C104, Cement-Mortar Lining for Ductile-Iron Pipe and Fittings for Water.
    - b. C105, Polyethylene Encasement for Gray and Ductile Cast-Iron Piping for Water and Other Liquids.
    - c. C110, Ductile Iron and Gray Iron Fittings, 3 IN through 48 IN for Water and Other Liquids.
    - d. C111, Gasket Joints for Cast Iron and Ductile Iron Pressure Pipe and Fittings.
    - e. C115, Flanged Ductile Iron Pipe with Threaded Flanges.
    - f. C150, Thickness Design of Ductile Iron Pipe.
    - g. C151, Ductile Iron Pipe, Centrifugally Cast-In-Metal Molds or Sand-Lined Molds, for Water or Other Liquids.
    - h. C153, Ductile-Iron Compact Fittings, 3 in. through 16 in. for Water and Other Liquids.
    - i. C600, Installation of Ductile Iron Water Main and Their Appearance.
    - j. C606, Grooved and Shouldered Joints.

**1.3 SUBMITTALS**

- A. Shop Drawings:
  - 1. See Section 01300 for requirements for the mechanics and administration of the submittal process.
  - 2. Certification of factory hydrostatic testing.
  - 3. If mechanical coupling system is used, submit piping, fittings, and appurtenant items which will be utilized to meet system requirements.

4. For restrained joint pipe, line layout and marking diagrams which indicate the specific number of each fitting and the location and the direction of each fitting in the completed line. In addition, the line layouts shall include: the pipe station and invert elevation at all changes in grade or horizontal alignment; all elements of curves and bends, both in horizontal and vertical alignment; and the limits of each reach of restrained joints.

## PART 2 PRODUCTS

### 2.1 GENERAL

- A. Mortar-lined and asphaltic-coated polyethylene-wrapped ductile iron pipe shall conform to ANSI/AWWA C151, C104, and C105, subject to the following supplemental requirements. The pipe shall be of the diameter and class shown, shall be furnished complete with rubber gaskets as indicated in the Contract Documents, and all specials and fittings shall be provided as required under the Contract Documents. The following pipe size and class shall be furnished:
  1. Ductile Iron piping shall be pressure Class 350, or thickness Class 50 as shown on the plans, including Restrained Joint where shown.
- B. **Handling and Storage:** The pipe shall be handled by devices acceptable to the OWNER, designed and constructed to prevent damage to the pipe coating/exterior. The use of equipment which might injure the pipe coating/exterior will not be permitted. Stockpiled pipe shall be suitably supported and shall be secured to prevent accidental rolling. All other pipe handling equipment and methods shall be acceptable to the OWNER.
- C. **Laying Lengths:** Maximum pipe laying lengths shall be 20 feet with shorter lengths provided as required by the Drawings.
- D. **Finish:** The pipe shall have smooth dense interior surfaces and shall be free from fractures, excessive interior surface crazing and roughness.
- E. **Closures and Correction Pieces:** Closures and correction pieces shall be provided as required so that closures may be made due to different headings in the pipe laying operation and so that correction may be made to adjust the pipe laying to conform to field conditions.
- F. The CONTRACTOR shall be fully liable for the cost of replacement or repair of pipe provided by the CONTRACTOR under this contract which is damaged. The CONTRACTOR shall also be fully liable for the cost of replacement or repair of the pipe provided by the OWNER under this contract which is damaged by the CONTRACTOR as a result of improper handling.

### 2.2 PIPE DESIGN CRITERIA

- A. **General:** Ductile iron pipe shall be designed in accordance with the requirements of ANSI/AWWA C150 as applicable and as modified in this Section.
- B. **Minimum Pipe Wall Thickness:** In addition to the requirements of this Section, provide thicker wall pipe where required for grooved ends, or provide shoulder grooved ends.
- C. **Pipe Wall Thickness for Internal Pressure:** The pipe shall be designed with a net thickness to withstand the specified design and test pressure.



## 2.3 MATERIALS

- A. **Ductile Iron Pipe:** Pipe materials shall conform to the requirements of ANSI/AWWA C151.
- B. **Cement:** Cement for mortar lining shall conform to the requirements of ANSI/AWWA C104; provided, that cement for mortar lining shall be Type II or V. Cement shall not originate from kilns which burn metal-rich hazardous waste fuel, nor shall a fly ash or pozzolan be used as a cement replacement.
- C. **Polyethylene Encasement:** Shall conform to the requirements of ANSI/AWWA C105/A21.5.
  - 1. Minimum thickness shall be 8 mils.

## 2.4 SPECIALS AND FITTINGS

- A. Fittings for ductile iron pipe shall conform to the requirements of ANSI/AWWA C153/A21.53 or ANSI/AWWA C110/A21.10 for diameters 3-inch through 48-inch and shall have a minimum test pressure rating of 300 psi and working pressure rating of 250 psi.

## 2.5 DESIGN OF PIPE

- A. **General:** The pipe furnished shall be ductile iron pipe, mortar-lined and asphaltic-coated polyethylene-wrapped, with styrene butadiene (SBR)-gasketed joints. Nitrile butadiene rubber (NBR) gaskets may be requested at specific locations as an alternate to SBR. All gaskets must conform to ANSI/AWWA C111.
- B. The pipe shall be designed, manufactured, tested, inspected, and marked according to applicable requirements previously stated and except as hereinafter modified, shall conform to ANSI/AWWA C151.
- C. **Pipe Dimensions:** The pipe shall be of the diameter and class shown.
- D. **Fitting Dimensions:** The fittings shall be of the diameter and class shown.
- E. **Joint Design:** Ductile iron pipe and fittings shall be furnished with mechanical joints, push-on joints, flanged joints, and restrained joints as required.
  - 1. Mechanical and push-on joints shall conform to ANSI/AWWA C111/A21.11.
  - 2. Flanged joints shall conform to ANSI/AWWA C115/A21.15.
  - 3. Restrained joints shall utilize a positive restraint method, such as "Flex-Ring" or "Lok-Ring" Restrained Joint by American Ductile Iron Pipe, "TR FLEX" Restrained Joint by U.S. Pipe, or approved equal, "Field Flex-Ring" or "Fast Grip" by American Ductile Iron Pipe or the "TR Flex-Gripper Ring" or "Field Lock Gasket" by U.S. Pipe, or Megalug by EBAA Foundry. Restrained joints using friction restraint such as set screws, anchor lugs, exposed bolts in the thrust restraint assembly are unacceptable
- F. For bell-and-spigot ends with rubber gaskets, the clearance between the bells and spigots shall be such that when combined with the gasket groove configuration and the gasket itself, will provide watertight joints under all operating conditions when properly installed. The CONTRACTOR shall require the pipe manufacturer to submit details complete with significant dimensions and tolerances and also to submit performance data indicating that the proposed joint has performed satisfactorily under similar conditions. In the absence of a history of field performance, the results of a test program shall be submitted.

## 2.6 CEMENT-MORTAR LINING

- A. **Cement-Mortar Lining for Shop Application:** Except as otherwise provided herein, interior surfaces of all ductile iron pipe, fittings, and specials shall be cleaned and lined in the shop with cement-mortar lining applied centrifugally in conformity with ANSI/AWWA C104. During the lining operation and thereafter, the pipe shall be maintained in a round condition by suitable bracing or strutting. The lining machines shall be of a type that has been used successfully for similar work. Every precaution shall be

taken to prevent damage to the lining. If lining is damaged or found faulty at delivery site, the damaged or unsatisfactory portions shall be replaced with lining conforming to these Specifications.

## 2.7 EXTERIOR COATING OF PIPE

- A. **Exterior Coating of Buried Piping:** The exterior coating shall be an asphaltic coating approximately 1 mil thick.

## PART 3 EXECUTION

### 3.1 INSTALLATION OF PIPE

- A. The Contract Documents require that the CONTRACTOR installs all mechanical and piping systems as a part of the WORK.
- B. **Handling and Storage:** All pipe, fittings, etc., shall be carefully handled and protected against damage, impact shocks, and free fall. All pipe handling equipment shall be acceptable to the OWNER. Pipe shall not be placed directly on rough ground but shall be supported in a manner which will protect the pipe against injury whenever stored at the trench site or elsewhere. No pipe shall be installed where the lining or coating show defects that may be harmful as determined by the OWNER. Such damaged lining or coating shall be repaired, or a new undamaged pipe shall be furnished and installed.
- C. All pipe damaged prior to Substantial Completion shall be repaired or replaced by the CONTRACTOR.
- D. The CONTRACTOR shall inspect each pipe and fitting prior to installation to insure that there are no damaged portions of the pipe.
- E. Before placement of pipe in the trench, each pipe or fitting shall be thoroughly cleaned of any foreign substance, which may have collected thereon and shall be kept clean at all times thereafter. For this purpose, the openings of all pipes and fittings in the trench shall be closed during any interruption to the WORK.
- F. **Pipe Laying:** The pipe shall be installed in accordance with ANSI/AWWA C600.
- G. Pipe shall be laid directly on the bedding material. No blocking will be permitted, and the bedding shall be such that it forms a continuous, solid bearing for the full length of the pipe. Excavations shall be made as needed to facilitate removal of handling devices after the pipe is laid. Bell holes shall be formed at the ends of the pipe to prevent point loading at the bells or couplings. Excavation shall be made as needed outside the normal trench section at field joints to permit adequate access to the joints for field connection operations and for application of coating on field joints.
- H. Each section of restrained joint pipe shall be laid in the order and position shown on the laying schedule. In laying pipe, it shall be laid to the set line and grade, within approximately one inch plus or minus. On grades of zero slope, the intent is to lay to grade.
- I. Where necessary to raise or lower the pipe due to unforeseen obstructions or other causes, the OWNER may change the alignment and/or the grades. Such change shall be made by the deflection of joints, by the use of bevel adapters, or by the use of additional fittings. However, in no case shall the deflection in the joint exceed the maximum deflection recommended by the pipe manufacturer. No joint shall be misfit any amount which will be detrimental to the strength and water tightness of the finished joint.
- J. Except for short runs which may be permitted by the OWNER, pipes shall be laid uphill on grades exceeding 10 percent. Pipe which is laid on a downhill grade shall be blocked and held in place until sufficient support is furnished by the following pipe to prevent movement. All bends shall be properly installed as shown.

- K. **Cold Weather Protection:** No pipe shall be installed upon a foundation into which frost has penetrated or at any time that there is a danger of the formation of ice or penetration of frost at the bottom of the excavation. No pipe shall be laid unless it can be established that the trench will be backfilled before the formation of ice and frost occurs.
- L. **Pipe and Specials Protection:** The openings of all pipe and specials shall be protected with suitable bulkheads to prevent unauthorized access by persons, animals, water or any undesirable substance. At all times, means shall be provided to prevent the pipe from floating.
- M. **Pipe Cleanup:** As pipe laying progresses, the CONTRACTOR shall keep the pipe interior free of all debris. The CONTRACTOR shall completely clean the interior of the pipe of all sand, dirt, mortar splatter and any other debris following completion of pipe laying, pointing of joints and any necessary interior repairs prior to testing and disinfecting the completed pipeline.

### 3.2 RUBBER GASKETED JOINTS

- A. **Rubber Gasketed Joints:** Immediately before jointing pipe, the bell end of the pipe shall be thoroughly cleaned, and a clean rubber (SBR or NBR) gasket lubricated with an approved vegetable-based lubricant shall be placed in the bell groove. The spigot end of the pipe shall be carefully cleaned and lubricated with a vegetable-based lubricant. The spigot end of the pipe section shall then be inserted into the bell of the previously laid joint and telescoped into its proper position. Tilting of the pipe to insert the spigot into the bell will not be permitted.

### 3.3 JOINING METHOD

#### A. Joining Method - Push-On Mechanical (Gland-Type) Joints:

1. Install in accordance with AWWA C111.
2. Assemble mechanical joints carefully according to manufacturer's recommendations.
3. If effective sealing is not obtained, disassemble, thoroughly clean, and reassemble the joint.
4. Do not overstress bolts.
5. Where piping utilizes mechanical joints with tie rods, align joint holes to permit installation of harness bolts.

#### B. Joining Method - Push-On Joints:

1. Install in accordance with AWWA C151.
2. Assemble push-on joints in accordance with manufacturer's directions.
3. Bevel and lubricate spigot end of pipe to facilitate assembly without damage to gasket. Use lubricant that is non-toxic, does not support the growth of bacteria, has no deteriorating effects on the gasket material, and imparts no taste or odor to water in pipe.
4. Assure the gasket groove is thoroughly clean.
5. For cold weather installation, warm gasket prior to placement in bell.
6. Taper of bevel shall be approximately 30 degrees with centerline of pipe and approximately 1/4 IN back.

#### C. Joining Method - Flanged Joints:

1. Install in accordance with AWWA C115.
2. Extend pipe completely through screwed-on flanged and machine flange face and pipe in single operation.
3. Make flange faces flat and perpendicular to pipe centerline.
4. When bolting flange joints, exercise extreme care to ensure that there is no restraint on opposite end of pipe or fitting which would prevent uniform gasket compression or would cause unnecessary stress, bending or torsional strains to be applied to cast flanges or flanged fittings.
5. Allow one flange free movement in any direction while bolts are being tightened.
6. Do not assemble adjoining flexible joints until flanged joints in piping system have been tightened.
7. Gradually tighten flange bolts uniformly to permit even gasket compression.

**D. Joining Method - Mechanical Coupling Joint:**

1. Arrange piping so that pipe ends are in full contact.
2. Groove and shoulder ends of piping in accordance with manufacturer's recommendations.
3. Provide coupling and grooving technique assuring a connection which passes pressure testing requirements.

**E. Flange Adaptors 12 IN and Less:**

1. Locate and drill holes for anchor studs after pipe is in place and bolted tight.
2. Drill holes not more than 1/8 IN larger than diameter of stud projection.

**F. Cutting:**

1. Do not damage interior lining material during cutting.
2. Use abrasive wheel cutters or saws.
3. Make square cuts.
4. Bevel and free cut ends of sharp edges after cutting.

G. Support exposed pipe as shown on the Drawings.

**3.4 INSTALLATION OF POLYETHYLENE ENCASUREMENT**

- A. Installation shall be according to the requirements set forth in ANSI/AWWA C105/A21.5 and DIPRA's "Polyethylene Encasement" brochure.
- B. Encase underground appurtenances required as part of installation.
- C. Where tapping polyethylene encased pipe, first wrap location of tap with three layers of polyethylene adhesive tape. Make tap through tape.
- D. Make sections 2 FT longer than pipe section to be covered.
- E. Slip tube over pipe while pipe is suspended immediately before placing in trench.
- F. After installing in trench, pull tube ends over joint and overlap.
- G. Fasten securely in-place on each side of each joint with joint tape or strapping.
- H. Pull loose tube along pipe barrel up snugly around pipe and fasten in-place with joint tape at 3 FT intervals.
- I. Completely cover fittings and connections with film held snugly in-place with joint tape or strapping.
- J. Repair cuts, tears, punctures, or damage to polyethylene with adhesive tape or a short length of polyethylene sheet, or with a tube cut open, wrapped around the pipe to cover the damage area and enclose with adhesive tape and secured in place.

**3.5 INSTALLATION OF PIPE APPURTENANCES**

- A. **Protection of Appurtenances:** Where pipe is encased in polyethylene sleeves, buried appurtenances shall also be encased in polyethylene.
- B. **Installation of Valves:** All valves shall be handled in a manner to prevent any injury or damage to any part of the valve. All joints shall be thoroughly cleaned and prepared prior to installation. The CONTRACTOR shall adjust all stem packing and operate each valve prior to installation to insure proper operation.

C. All valves shall be installed so that the valve stems are plumb and in the location shown.

**3.6 TESTING AND DISINFECTION**

A. Test and disinfect pipe in accordance with applicable portions of Section 15950.

B. Bonding of all pipe joints shall be tested to confirm continuity of bonding.

**3.7 CONNECTIONS TO EXISTING PIPELINE**

A. Testing piping systems in accordance with Section 15950.

B. Following approved testing and disinfection of pipe, the District crew will make all final connection to existing metered water services and existing pipeline as shown on the Drawings.

**END OF SECTION**

**SECTION - 15080**  
**PIPE: PLASTIC CROSSLINKED POLYETHYLENE**  
**(REHAU MUNICIPEXU PIPE)**

**PART 1 GENERAL**

**1.1 SUMMARY**

- A. Municipal water service piping system, where shown on the Drawings and Schedules, shall be crosslinked polyethylene pipe, and shall include the following:
1. Crosslinked polyethylene (PEXa) piping
    - a. Produced in accordance with AWWA C904
    - b. Required 200 psi pressure rating at 73.4°F (23°F) when using a 0.63 design factor
    - c. Required 1 year UV resistance rating in accordance with ASTM F876
  2. Approved AWWA C800 compression joint valves and fittings, suitable for buried applications, using stainless steel or plastic support liners inside pipe at each joint and/or cold-expansion and compression-sleeve fittings.
  3. Supervision and field engineering required for the complete and proper function of the system as deemed necessary per specifying engineer.

**1.2 REFERENCE**

- A. Publications listed here are part of this specification to the extent they are referenced. Where no specific edition of the standard or publication is identified, the current edition shall apply.
- B. ASTM – American Society for Testing and Materials
1. ASTM F876 – Standard Specification for Crosslinked Polyethylene (PEX) Tubing
  2. ASTM F877 – Standard Specification for Crosslinked Polyethylene (PEX) Plastic Hot- and Cold-Water Distribution Systems
  3. ASTM F2023 – Standard Test Method for Evaluating the Oxidative Resistance of Crosslinked Polyethylene (PEX) Tubing and Systems to Hot Chlorinated Water
  4. ASTM F2080 – Standard Specification for Cold-Expansion Fittings with Metal Compression-Sleeves for Crosslinked Polyethylene (PEX) Pipe
- C. AWWA – American Water Works Association
1. AWWA C904 – Crosslinked Polyethylene (PEX) Pressure Pipe, 1/2 in.(12 mm) Through 3 in. (76 mm), for Water Service
  2. AWWA C800 – Underground Service Line Valves and Fittings
- D. CSA Canadian Standards Associations
1. CSA B137.5 – Crosslinked Polyethylene (PEX) Tubing Systems for Pressure Applications
- E. ICC – International Code Council
- F. ISO – International Organization for Standardization
1. ISO 9001 – Quality Management Systems – Requirements
- G. NSF International
1. NSF/ANSI 14 – Plastic Piping System Components and Related Materials
  2. NSF/ANSI 61 – Drinking Water System Components – Health Effects
- H. Plastic Pipe Institute
1. PPI TR-3 – Policies and Procedures for Developing Hydrostatic Design Basis (HDB), pressure Design Basis (PDB), Strength Design Basis (SDB) and Minimum Required Strength (MRS) Ratings for Thermoplastic Piping Materials or Pipe

### 1.3 DEFINITIONS

- A. Crosslinked polyethylene, commonly abbreviated PEX, is made from high-density polyethylene (HDPE). Crosslinking is accomplished during manufacturing. Crosslinking enhances the physical and mechanical properties of the polymer. The high-temperature properties are improved. Chemical resistance is enhanced by resisting dissolution. Low temperature properties are also improved. Impact and tensile strength, scratch resistance and resistance to brittle fracture are enhanced. The required degree of crosslinking, according to ASTM Standard F876, is between 70-89%. This specification requires PEX to be designated as PEXa and be manufactured by the high-pressure peroxide method.

### 1.4 SYSTEM DESCRIPTOIN

- A. Design Requirements
  - 1. Standard grade hydrostatic pressure ratings from Plastics Pipe Institute in accordance with PPI TR-3. The following three standard-grade hydrostatic ratings are required:
    - a. 100 psi (690 kPa) at 180°F (82°C)
    - b. 160 psi (1105 kPa) at 73.4°F (23°C)
    - c. 200 psi (1378 kPa) at 73.4°F (23°C) when using a 0.63 design factor.
- B. Performance Requirements: To provide a municipal water piping system, which is manufactured, fabricated and installed to comply with regulatory agencies and to maintain performance criteria stated by the PEXa pipe manufacturer without defects, damage or failure.
- C. Compliant to the following standards:
- D. AWWA C904
  - 1. NSF/ANSI Standard 14
  - 2. NSF/ANSI Standard 61
  - 3. ASTM F876
  - 4. CSA B137.5

### 1.5 SUBMITTALS

- A. Comply with Section 01300 and Manufacturers Certifications as set forth in this specification.
- B. Product Data: Submit manufacturer's Technical Manual, submittal forms, catalog cuts, brochures, specifications and installation instructions. Submit data in sufficient detail to indicate compliance with the contract documents.
  - 1. Submit manufacturer's instructions for installation.
  - 2. Submit data for equipment, fittings, fasteners and associated items necessary for the installation of the piping and manifolds.
- C. Submit computer-generated system design indicating pipe sizing, flow rates and temperatures.
- D. Shop Drawings: Provide plans drawn to scale for all installation areas.
  - 1. Indicate dimensions, descriptions of materials, general construction, component connections and installation procedures.
  - 2. Indicate design, schematic layout of system, including equipment and critical dimensions as well as details for protecting exposed PEXa piping.
- E. Certification:
  - 1. Fittings shall be third-party as approved by the manufacturer's PEXa piping system with applicable plumbing and mechanical code certifications.

- F. Maintenance Instructions: Submit instructions for any maintenance required or recommended by manufacturer.

## **1.6 QUALITY ASSURANCE**

- A. Comply with Section 01400, Quality Assurance.
- B. Manufacturer: Must be a company specializing in the Work of this Section with a minimum of 5 years documented experience.
- C. Pipe shall be manufactured in a facility whose quality management system is ISO 9001 certified.
- D. Crosslinked polyethylene (PEXa) pipe shall conform and be certified to AWWA C904, ASTM F876, F877 and CSA B137.5. Fittings shall conform and be certified to AWWA C800, or ASTM F877, F2080 and CSA B137.5.

## **1.7 DELIVERY, STORAGE AND HANDLING**

- A. Comply with Section 01600, Product Requirements.
- B. Deliver and store pipe and equipment in shipping containers with labeling in place.
  - 1. Pipe shall be kept in original shipping boxes until required for installation.
- C. Store pipe and equipment in a safe place, dry, enclosed, under cover, in a well-ventilated area.
  - 1. Do not expose pipe to ultraviolet light beyond exposure limits recommended by manufacturer.
  - 2. Protect pipe from entry of contaminating materials. Install suitable plugs in open pipe ends until installation.
  - 3. Pipe shall not be dragged across the ground or other surfaces, and shall be stored on a flat surface with no sharp edges.
- D. Protect materials from damage by other trades.
- E. Pipe shall be protected from oil, grease, paint, direct sunlight and other elements as recommended by manufacturer.

## **1.8 WARRANTY**

- A. Provide manufacturer's standard written warranty.
  - 1. The warranty shall include as a minimum, provisions to repair defects from faulty materials or workmanship developed during the guarantee period, or provide for replacement with new materials, at no expense to Owner.
  - 2. The pipe manufacturer shall warrant the crosslinked polyethylene pipe to be free from defects in material and workmanship for a minimum period of one (1) years starting at completion and acceptance of the project by the District Board of Directors.
  - 3. All fittings and hardware shall be warranted to be free from defects in material and workmanship for a period of one (1) years starting at completion and acceptance of the project by the District Board of Directors.
- B. Provide installer's guarantee as appropriate.



## **PART 2 PRODUCTS**

### **2.1 ACCEPTABLE MANUFACTURER**

- A. REHAU Construction LLC, or equal

### **2.2 COMPONENTS**

#### **A. Piping**

1. All pipe shall be high-density crosslinked polyethylene manufactured using the high-pressure peroxide method of crosslinking (PEXa). Pipe shall conform to AWWA C904, ASTM F876, ASTM F877, CSA B137.5, NSF/ANSI 14 and NSF/ANSI 61.
2. Pipe shall be rated for continuous operation of 100 psi gauge pressure at 180°F temperature (690 kPa @ 82°C), and 160 psi gauge pressure at 73.4°F temperature (1105 kPa @ 23°C).
3. Pipe shall be rated for continuous operation at 200 psi gauge pressure at 73.4°F temperature (1378 kPa @ 23°C) when using a 0.63 design factor.
4. Pipe shall be listed by PPI to standard TR-3, with applicable plumbing and mechanical code certifications.
5. Pipe to be manufactured using a high-pressure peroxide method with a minimum degree of crosslinking of 70-89% when tested in accordance with ASTM D2765, Method B.
6. Pipe to be tested for resistance to hot chlorinated water in accordance with ASTM F2023. Pipe to have a minimum extrapolated time-to-failure of 50 years, calculated in accordance with section 13.3 of F2023 and listed as “3306” per the ASTM F876 standard.
7. Pipe to have a co-extruded UV Shield made from UV-resistant high-density polyethylene, color blue. Pipe to have minimum recommended UV exposure time of one year when tested in accordance with ASTM F2657.
8. Pipe shall be manufactured in a facility whose quality management system is ISO 9001 certified.
9. Bend Radius: The minimum bend radius for cold bending of pipe shall be not less than five (5) times the outside diameter.

#### **B. Pipe Fittings**

1. Mechanical fittings to be of compression joint or compression-sleeve style, manufactured of metal suitable for the fluid application, in a size suitable for the PEXa pipe dimensions.
2. Compression joint fittings shall be manufactured in accordance with AWWA C800. Fittings must meet the pressure requirements of the PEXa pipe at 73.4°F (23°C)
3. Compression-sleeve fittings shall be manufactured of brass and shall be supplied by the pipe manufacturer as part of a proven cataloged system.
4. Where fittings are encased in concrete or buried underground, fittings shall be wrapped as per manufacturer’s recommendation to protect the material.

### **2.3 PIPE MARKING**

- A. Pipe shall carry the following markings every three (3) feet (0.9 meters): Manufacturer’s name or trademark, nominal size, PEXa 3306 (material designation) SDR9 (standard dimension ratio), POTABLE TUBING, ASTM F876/ F877 / F2080, CSA B137.5, NSF-pw, UP Code 200psi/73.4°F at 0.63 design factor 160psi/73.4°F 100psi/180°F, POTABLE TUBING, manufacturing date and footage mark.

## **2.4 PACKAGING**

- A. Coiled pipe shall be shipped in protective cardboard boxes marked with product name and size.
- B. Straight lengths shall be packed in plastic bags.

## **PART 3 INSTALLATION OF PIPE**

### **3.1 INSTALLATION:**

- A. Install in accordance with manufacturer's published installation manual and/or published guidelines and final shop drawings.
- B. At connections and fittings, use a plastic pipe cutter to ensure square (90°) and clean cuts, and join pipes immediately or cap ends of pipe to seal from contaminants.
- C. Pipe shall be dispensed using a suitable uncoiling device. Remove twists prior to securing pipe. Pipe shall lie flat on an even plane.
- D. Pipe that passes through expansion joints or walls shall be covered in protective polyethylene convoluted sleeving (flexible conduit) extending 15 in (38 cm) on each side of the joint. Sleeving shall be secured on pipe to prevent movement during installation.
- E. Where pipe enters or exits a wall, a protective conduit shall be placed around the pipe, with the conduit extending a minimum of 6 inches (15 cm) into the floor and exiting by a minimum of 6 in. (15 cm). For penetrations at manifolds, use rigid PVC bend guides secured in place to prevent movement.

### **3.2 TESTING**

- A. Testing piping systems in accordance with Section 15950.
- B. Following approved testing and disinfection of pipe and service transfers, make connections to existing pipeline as shown on the Drawings. Conform to applicable portions of Section 15950.

**END OF SECTION**

**SECTION - 15100**  
**VALVES: BASIC REQUIREMENTS**

**PART 1 GENERAL**

**1.1 SUMMARY**

- A. Section Includes:
  - 1. Valving, actuators, and valving appurtenances.
  
- B. Related Sections include but are not necessarily limited to:
  - 1. Skagit Public Utility District No. 1 General Conditions.
  - 2. Division 1 - General Requirements.
  - 3. Section 15000 - Piping General.
  
- C. Unit Responsibility: For the piping systems that are required to be provided by the CONTRACTOR, a single manufacturer shall be made responsible for coordination of design, assembly, testing, and furnishing of each valve; however, the CONTRACTOR shall be responsible to the OWNER for compliance with the requirements of each valve section. Unless indicated otherwise, the responsible manufacturer shall be the manufacturer of the valve.
  
- D. Single Manufacturer: Where two or more valves of the same type or size are required, the valves shall be furnished by the same manufacturer.

**1.2 QUALITY ASSURANCE**

- A. Referenced Standards:
  - 1. American National Standards Institute (ANSI):
    - a. B1.20.1, Pipe Threads, General Purpose.
    - b. B16.1, Cast Iron Pipe Flanges and Flanged Fittings.
    - c. B16.18, Cast Copper Alloy Solder Joint Pressure Fittings.
    - d. B16.34, Valves-Flanged, Threaded and Welding End.
  - 2. ASTM International (ASTM):
    - a. A126, Standard Specification for Gray Iron Castings for Valves, Flanges, and Pipe Fittings.
    - b. D256, Standard Test Methods for Determining the Izod Pendulum Impact Resistance of Plastics.
    - c. D638, Standard Test Method for Tensile Properties of Plastics.
    - d. D648, Standard Test Method for Deflection Temperature of Plastics Under Flexural Load.
    - e. D695, Standard Test Method for Compressive Properties of Rigid Plastics.
    - f. D2240, Standard Test Method for Rubber Property-Durometer Hardness.
  - 3. American Water Works Association (AWWA):
    - a. C111, Rubber-Gasket Joints for Ductile Iron and Gray Iron Pressure Pipe and Fittings.
    - b. C207, Steel Pipe Flanges for Waterworks Service - Sizes 4 IN through 144 IN.
    - c. C500, Gate Valves for Water and Sewerage Systems.
    - d. C504, Rubber-Seated Butterfly Valves.
    - e. C507, Ball Valves, 6 IN through 48 IN (150 MM through 1200 MM).
    - f. C509, Resilient-Seated Gate Valves 3 through 12 NPS, for Water and Sewage Systems.
    - g. C540, Power-Actuating Devices for Valves and Sluice Gates.
    - h. C550, Protective Epoxy Interior Coatings for Valves and Hydrants.
    - i. C606, Grooved and Shouldered Joints.
  - 4. Manufacturers Standardization Society of the Valve and Fittings Industry, Inc.(MSS).
  - 5. National Electrical Manufacturers Association (NEMA):
    - a. 250, Enclosures for Electrical Equipment (1000 Volt Maximum).
    - b. MG 1, Motors and Generators.

### **1.3 DEFINITIONS**

- A. The following are definitions of abbreviations used in this section or one of the individual valve sections:
  - 1. CWP: Cold water working pressure.
  - 2. WWP: Water working pressure.

### **1.4 CONTRACTOR SUBMITTALS**

- A. General: Submittals shall be furnished in accordance with Section 01300.
- B. Shop Drawings: Shop Drawings for the valves that are within the CONTRACTOR's scope of supply and responsibility shall contain the following information:
  - 1. Valve name, size, valve flow coefficient (Cv factor), pressure rating, identification number (if any), and specification section number.
  - 2. Complete information on valve actuator, including size, manufacturer, model number, limit switches, and mounting.
  - 3. Cavitation limits for all control valves.
  - 4. Assembly drawings showing part nomenclature, materials, dimensions, weights, special linings, and relationships of valve handles, handwheels, position indicators, limit switches, integral control systems, needle valves, and control systems.
  - 5. Complete wiring diagrams and control system schematics.
  - 6. Valve Labeling: A schedule of valves to be labeled, indicating in each case the valve location and the proposed working for the label.
  - 7. Acknowledgement that products submitted meet requirements of standard referenced.
- C. Spare Parts List: A Spare Parts List shall contain the required information for each valve assembly, where indicated.
- D. Factory Test Data: Where indicated, signed, dated, and certified factory test data for each valve requiring certification shall be submitted before shipment of the valve. The data shall also include certification of quality and test results for factory-applied coatings.

## **PART 2 PRODUCTS**

### **2.1 ACCEPTABLE MANUFACTURERS**

- A. Refer to individual valve Specification Sections.

### **2.2 MATERIALS**

- A. General: All materials shall be suitable for the intended application. Materials not specified shall be high-grade standard commercial quality, free from all defects and imperfections that might affect the serviceability of the product for the purpose for which it is intended. Unless otherwise specified, valve and actuator bodies shall conform to the following requirements:
  - 1. Cast Iron: Close-grained gray cast iron, conforming to ASTM A48 – Specification for Gray Iron Castings, Class 30, or to ASTM A126 – Specification for Gray Iron Castings for Valves, Flanges, and Pipe Fittings.
  - 2. Ductile Iron: ASTM A536 – Specifications for Ductile Iron Castings, or to ASTM A395 – Specifications for Ferric Ductile Iron Pressure-Retaining Castings for Use at Elevated Temperatures.
  - 3. Steel: ASTM A216 – Specification for Steel Castings, Carbon Suitable for Fusion Welding for High-Temperature Service, or to ASTM A515 – Specification for Pressure Welding for Pressure Vessel Plates, Carbon Steel, for Intermediate- and Higher-Temperature Service.
  - 4. Bronze: ASTM B62 – Specification for Composition Bronze or Ounce Metal Castings, and valve stems not subject to dezincification shall conform to ASTM B584 – Specification for Copper Alloy Sand Castings for General Applications.

5. Stainless Steel: Stainless steel valve and operator bodies and trim shall conform to ASTM A351 – Specification for Steel Castings, Austenitic, for High-Temperature Service, Grade CF8M, or shall be Type 316 stainless steel.

## **2.3 VALVE CONSTRUCTION**

- A. Unless otherwise noted valves shall be rated for 250 PSI working pressure.
- B. Bodies: Valve bodies shall be cast, forged, or welded of the materials indicated, with smooth interior passages. Wall thicknesses shall be uniform in agreement with the applicable standards for each type of valve, without casting defects, pinholes, or other defects that could weaken the body. All welds on welded bodies shall be done by certified welders and shall be ground smooth. Valve ends shall be as indicated, and be rated for the maximum temperature and pressure to which the valve will be subjected.
- C. Bonnets: Valve bonnets shall be clamped, screwed, or flanged to the body and shall be of the same material, temperature, and pressure rating as the body. The bonnets shall have provision for the stem seal with the necessary glands, packing nuts, or yokes.
- D. Stems: Valve stems shall be of the materials indicated, or, if not indicated, of the best commercial material for the specific service, with adjustable stem packing, O-rings, Chevron V-type packing, or other suitable seal. Where subject to dezincification, bronze valve stems shall conform to ASTM B62, containing not more than 5 percent of zinc or more than 2 percent of aluminum, with a minimum tensile strength of 60,000 psi, a minimum yield strength of 40,000 psi, and an elongation of at least 10 percent in 2 inches. Where dezincification is not a problem, bronze conforming to ASTM B584 may be used.
- E. Internal Parts: Internal parts and valve trim shall be as indicated for each individual valve. Where not indicated, valve trim shall be of Type 316 stainless steel or other best suited material.
- F. All bolts used in buried flanges shall be ASTM A307 Grade B unfinished with nuts to ASTM A563 Grade A and washers to ASTM F8444 or ASTM A325 Type 3 (corten steel) unfinished, with nuts to ASTM A563C3 or A563DH3 and washers to ASTM F436-1. All bolts, nuts and washers used in exposed or above ground locations shall be ASTM/A307 Grade B unfinished or hot-dip galvanized.

## **2.4 VALVE ACCESSORIES**

- A. All valves shall be furnished complete with the accessories required to provide a function system.

## **2.5 SPARE PARTS**

- A. Where indicated, the CONTRACTOR shall furnish the required spare parts suitably packaged and labeled with the valve name, location, and identification number. The CONTRACTOR shall also furnish the name, address, and telephone number of the nearest distributor for the spare parts of each valve. All spare parts are intended for use by the OWNER, only, after expiration of the guarantee period.

## **2.6 VALVE ACTUATORS**

- A. Valve Actuators - General:
  1. Unless otherwise indicated, valves shall be furnished with manual actuators.
  2. Provide actuators as shown on Drawings or specified.
  3. Counter clockwise opening as viewed from the top.
  4. Direction of opening and the word OPEN to be cast in handwheel or valve bonnet.
  5. Size actuator to produce required torque with a maximum pull of 80 LB at the maximum pressure rating of the valve provided and withstand without damage a pull of 200 LB on handwheel or chainwheel or 300 foot-pounds torque on the operating nut.

6. Unless otherwise specified, actuators for valves to be buried, or installed in vaults or manholes shall be sealed to withstand at least 20 FT of submergence.
7. Extension Stem:
  - a. Install where shown or specified.
  - b. Solid steel with actuator key and nut, diameter not less than stem of valve actuator shaft.
  - c. Pin all stem connections.
  - d. Center in valve box or grating opening band with guide bushing.

**B. Buried Valve Actuators:**

1. Provide screw or slide type adjustable cast iron valve box, 5 IN minimum diameter, 3/16 IN minimum thickness, and identifying cast iron cover.
2. Box base to enclose buried valve gear box or bonnet.
3. Provide 2 IN standard actuator nuts complying with Section 3.16 of AWWA C500.
4. Provide at least two tee-handle keys for actuator nuts, with 5 FT extension between key and handle.
5. Extension Stem:
  - a. Provide for buried valves greater than 4 FT below finish grade.
  - b. Extend to within 6 IN of finish grade.
6. Provide concrete pad encasement of valve box as shown for all buried valves unless shown otherwise.

**C. Exposed Valve Manual Actuators:**

1. Provide for all exposed valves not having electric or cylinder actuators.
2. Provide handwheels for gate and globe valves.
  - a. Size handwheels for valves in accordance with AWWA C500.
3. Provide lever actuators for plug valves, butterfly valves and ball valves 3 IN DIA and smaller.
  - a. Lever actuators for butterfly valves shall have a minimum of 5 intermediate lock positions between full open and full close.
  - b. Provide at least two levers for each type and size of valve furnished.
4. Gear actuators required for butterfly valves, and ball valves 4 IN DIA and larger.
5. Gear actuators to be totally enclosed, permanently lubricated and with sealed bearings.
6. Provide chain actuators for valves 6 FT or higher from finish floor to valve centerline.
  - a. Cadmium-plated chain looped to within 3 FT of finish floor.
  - b. Equip chain wheels with chain guides to permit rapid operation with reasonable side pull without "gagging" the wheel.
7. Provide cast iron floor stands where shown on Drawings. Stands to be furnished by valve manufacturer with actuator.
  - a. Stand or actuator to include thrust bearings for valve operation and weight of accessories.

## **2.7 FABRICATION**

**A. End Connections:**

1. Provide the type of end connections for valves as required in the Piping Schedules presented in Section 15062 and 15070 or as shown on the Drawings.
2. Comply with the following standards:
  - a. Threaded: ANSI B1.20.1.
  - b. Flanged: ANSI B16.1 Class 125 unless otherwise noted or AWWA C207.
  - c. Bell and spigot or mechanical (gland) type: AWWA C111.
  - d. Soldered: ANSI B16.18.
  - e. Grooved: Rigid joints per Table 5 of AWWA C606.

**B. Refer to individual valve sections for specifications of each type of valve on Project.**

**C. Nuts, Bolts, and Washers:**

1. Wetted or internal to be bronze or stainless steel. Exposed to be zinc or cadmium plated.

- D. On Insulated Piping: Provide valves with extended stems to permit proper insulation application without interference from handle.
- E. Protective Coating and Lining:
  - 1. In accordance with AWWA C550 unless otherwise specified.
  - 2. Either two-part liquid material or heat-activated (fusion) material except only heat-activated material if specified as “fusion” or “fusion-bonded” epoxy.
  - 3. Minimum 7-mil dry film thickness except where limited by valve operating tolerances.
  - 4. The valve manufacturer shall certify in writing that the required coating has been applied and tested in the manufacturing plant prior to shipment, in accordance with these Specifications. Alternatively, if required coatings are applied outside of manufacturing plant, the manufacturer shall warrant the valve to the same standard provided for factory coated valves.
  - 5. Flange faces of valves shall not be epoxy coated.
  - 6. Lining shall be NSF approved.
- F. Valve Testing: As a minimum, unless otherwise indicated, each valve body 4 inches and larger shall be tested hydrostatically to 1.5 times its rated 100 degrees F design water-working pressure. In addition, each valve 4 inches and larger shall undergo a functional test to demonstrate satisfactory operation throughout its operating cycle, and a closure test at rated 100 degrees F water-working pressure for a period of 5 minutes to demonstrate tight shut-off. Stem seal leakage shall not be a cause for rejection. All valves 3 inches and smaller shall undergo the manufacturer’s standard test.
- G. Certification: Prior to shipment, the CONTRACTOR shall submit for all valves over 12 inches in size, certified, notarized copies of the hydrostatic factory tests, showing compliance with the applicable standards of AWWA, ANSI, and ASTM.
- H. Valve Marking: All valve bodies shall be permanently marked in accordance with MSS SP25 – Standard Marking Systems for Valves, Fittings, Flanges, and Unions.
- I. Underground Valves: Provide underground metallic valves with flanged, mechanical, or other type of joint required for the type of pipe to which the valve is to be connected. Plastic pipe shall be heat welded when buried and shall be flanged within any underground vaults and metering or valve boxes. Flanges attached to all plastic valves 2-inches in diameter and larger, shall meet the outside diameter and bolt hole dimensional requirements of ANSI/ASME B16.5.

## **PART 3 EXECUTION**

### **3.1 INSTALLATION**

- A. Install products in accordance with manufacturer's instructions.
- B. Setting Buried Valves:
  - 1. Locate valves installed in pipe trenches where buried pipe indicated on Drawings.
  - 2. Set valves and valve boxes plumb.
  - 3. Place valve boxes directly over valves with top of box being brought to surface of finished grade.
  - 4. Install in closed position.
  - 5. Place valve on firm footing in trench to prevent settling and excessive strain on connection to pipe.
  - 6. After installation, backfill up to top of box for a minimum distance of 4 FT on each side of box.
- C. Support exposed valves and piping adjacent to valves independently to eliminate pipe loads being transferred to valve and valve loads being transferred to the piping.
- D. For grooved coupling valves, install rigid type couplings {or provide separate support to prevent rotation of valve from installed position}.

- E. Install electric or cylinder actuators above or horizontally adjacent to valve and gear box to optimize access to controls and external handwheel.
- F. For threaded valves, provide union on one side within 2 FT of valve to allow valve removal.
- G. Install valves accessible for operation, inspection, and maintenance.
- H. Valve Accessories: Where combinations of valves, sensors, switches, and controls are indicated, the CONTRACTOR shall properly assemble and install such items so that all systems are compatible and operating properly. The relationship between interrelated items shall be clearly noted on shop drawing submittals.
- I. The exterior of all valve bodies shall be wrapped with 8 mil polyethylene wrap.

**END OF SECTION**



**SECTION - 15101  
GATE VALVES**

**PART 1 GENERAL**

**1.1 SUMMARY**

- A. Section Includes:
  - 1. Gate valves.
  
- B. Related Sections include but are not necessarily limited to:
  - 1. Skagit PUD No. 1 General Conditions.
  - 2. Division 1 - General Requirements.
  - 3. Section 15100 - Valves: Basic Requirements.

**1.2 QUALITY ASSURANCE**

- A. Referenced Standards:
  - 1. American Water Works Association (AWWA):
    - a. C515, Resilient-Seated Gate Valves for Water Supply Service.

**1.3 SUBMITTALS**

- A. Manufacturer's certification material is in compliance with material requirements.

**PART 2 PRODUCTS**

**2.1 RESILIENT WEDGE GATE VALVES:**

- A. Gate valves shall be manufactured in accordance with the latest revision of AWWA C515. Valves shall be certified to NSF Standard 61 and be manufactured to meet the following:
  - 1. All valves shall be of the inside screw, non-rising stem type, with O-ring stem seal.
  - 2. The valve actuators shall have counter-clockwise opening stems.
  - 3. Valves shall be resilient wedge type rated for 250 psi working pressure.
  - 4. Bubble-tight with rated pressure applied from either side.
  - 5. Body flanged end, flange drilling in accordance with ANSI B16.1, Class 125.
  
- B. Materials:
  - 1. Valve body/cover: ASTM A536 Grade 65-45-12 ductile iron.
  - 2. Valve wedge: ASTM A536 Grade 65-45-12 ductile iron totally encapsulated with rubber.
  - 3. Stem, stem nut: Bronze or stainless steel.
  - 4. Nuts and Bolts: Type 304, stainless steel to ASTM F593/A193 for bolts and F594/A194 for nuts.
  - 5. Coating System: Fusion bonded epoxy in accordance with AWWA C550.
  
- C. Other:
  - 1. 2-inch square AWWA operating nut.
  - 2. Valves 12-inch and larger shall be equipped with gear actuator.
  
- D. Design requirements:
  - 1. 250-psi working pressure.
  - 2. NRS O-ring stem seal.
  - 3. Provide gear actuator, 12 IN and larger valves.
  - 4. Provide roller tracks and scrapers for horizontal valves size 16 IN and larger.
  - 5. Provide bypass valve sized per AWWA C500.

- E. Actuators: Unless otherwise indicated, gate valves shall have cast iron or ductile iron handwheels with 2-inch square operating nuts, in accordance with Section 15100.

## **2.2 FABRICATION**

- A. General:
  - 1. Provide valves with clear waterways the full diameter of the valve.
- B. Support valves in accordance with MSS SP-9.

## **PART 3 EXECUTION**

### **3.1 INSTALLATION**

- A. See Section 15100.
- B. Where larger buried valves utilize smaller bypass valves, provide a second valve box installed over the bypass valve operating nut.
- C. Do not install gate valves inverted or with the stems sloped more than 45 degrees from the upright unless the valve was ordered and manufactured specifically for this orientation.
- D. The exterior of all valve bodies shall be wrapped with 8 mil polyethylene wrap.

**END OF SECTION**

**SECTION - 15110**  
**DUCTILE - IRON FITTINGS AND HYDRANTS**

**PART 1 GENERAL**

**1.1 SUMMARY**

- A. Section Includes:
  - 1. Ductile iron fittings.
  - 2. Polyethylene Encasement for ductile iron pipe fittings.
  - 3. Hydrants
  
- B. Related Sections include but are not necessarily limited to:
  - 1. Skagit PUD No. 1 General Conditions.
  - 2. Division 1 - General Requirements.
  - 3. Section-02300
  - 4. Section-02700
  - 5. Division 15

**1.2 QUALITY ASSURANCE**

- A. Referenced Standards:
  - 1. American National Standards Institute (ANSI):
    - a. B1.1, Unified Inch Screw Threads (UN and UNR Thread Form).
    - b. B16.1, Cast-Iron Pipe Flanges and Flanged Fittings, Class 25, 125, 250, and 800.
    - c. B16.21, Nonmetallic Flat Gaskets for Pipe Flanges.
  - 2. ASTM International (ASTM):
    - a. A183, Carbon Steel Track Bolts.
    - b. A193, Standard Specification for Alloy-Steel and Stainless Steel Bolting Materials for High-Temperature Service.
    - c. A194, Standard Specification for Carbon and Alloy Steel Nuts for Bolts for High-Pressure and High-Temperature Service.
    - d. A307, Standard Specification for Carbon Steel Bolts and Studs, 60,000 psi Tensile Strength.
    - e. B695, Standard Specification for Coatings of Zinc Mechanically Deposited on Iron and Steel.
    - f. C150, Specification for Portland Cement.
    - g. D1330, Rubber Sheet Gaskets.
  - 3. American Water Works Association (AWWA):
    - a. C104, Cement-Mortar Lining for Ductile-Iron Pipe and Fittings for Water.
    - b. C105, Polyethylene Encasement for Gray and Ductile Cast-Iron Piping for Water and Other Liquids.
    - c. C110, Ductile Iron and Gray Iron Fittings, 3 IN through 48 IN for Water and Other Liquids.
    - d. C111, Gasket Joints for Cast Iron and Ductile Iron Pressure Pipe and Fittings.
    - e. C115, Flanged Ductile Iron Pipe with Threaded Flanges.
    - f. C150, Thickness Design of Ductile Iron Pipe.
    - g. C151, Ductile Iron Pipe, Centrifugally Cast-In-Metal Molds or Sand-Lined Molds, for Water or Other Liquids.
    - h. C153, Ductile-Iron Compact Fittings, 3 in. through 16 in. for Water and Other Liquids.
    - i. C501
    - j. C600, Installation of Ductile Iron Water Main and Their Appearance.
    - k. C606, Grooved and Shouldered Joints.

### 1.3 SUBMITTALS

- A. Manufacturer Certification:
  - 1. Certification materials supplied meet criteria as specified.

## PART 2 PRODUCTS

### 2.1 GENERAL

- A. Fittings shall be of the diameter and class shown, shall be furnished complete with rubber gaskets.

### 2.2 SPECIALS AND FITTINGS

- A. Fittings for ductile iron pipe shall conform to the requirements of ANSI/AWWA C153/A21.53 or ANSI/AWWA C110/A21.10 for diameters 3-inch through 48-inch and shall have a minimum test pressure rating of 225 psi and working pressure rating of 150 psi.
- B. Fittings shall be furnished inclusive of mortar-lined and seal coated in accordance with ANSI/AWWA C104/A21.4.
- C. The fittings shall be of the diameter and class shown.
- D. **Joint Design:** Ductile iron pipe and fittings shall be furnished with mechanical joints, push-on joints, flanged joints, and restrained joints as required.
  - 1. Mechanical and push-on joints shall conform to ANSI/AWWA C111/A21.11.
  - 2. Flanged joints shall conform to ANSI/AWWA C110/A21.10-12, flange drilling in accordance with ANSI B16.1, Class 125.
  - 3. Restrained joints shall utilize a positive restraint method, such as Grip Ring by Ford or approved equal. Restrained joints using friction restraint such as set screws, anchor lugs, exposed bolts in the thrust restraint assembly are unacceptable
- E. For bell-and-spigot ends with rubber gaskets, the clearance between the bells and spigots shall be such that when combined with the gasket groove configuration and the gasket itself, will provide watertight joints under all operating conditions when properly installed. The CONTRACTOR shall require the pipe manufacturer to submit details complete with significant dimensions and tolerances and also to submit performance data indicating that the proposed joint has performed satisfactorily under similar conditions. In the absence of a history of field performance, the results of a test program shall be submitted.

### 2.3 CEMENT-MORTAR LINING

- A. **Cement-Mortar Lining for Shop Application:** Except as otherwise provided herein, interior surfaces of all ductile iron fittings shall be cleaned and lined in the shop with cement-mortar lining applied centrifugally in conformity with ANSI/AWWA C104/21.4. During the lining operation and thereafter, the fittings shall be maintained in a round condition by suitable bracing or strutting. Every precaution shall be taken to prevent damage to the lining. If lining is damaged or found faulty at delivery site, the damaged or unsatisfactory portions shall be replaced with lining conforming to these Specifications.

### 2.4 EXTERIOR COATING

- A. **Exterior Coating of Fittings:** The exterior coating shall be an asphaltic coating approximately 1 mil thick.
- B. The exterior of all ductile iron fittings shall be wrapped with 8 mil polyethylene wrap.

## 2.5 HYDRANTS

- A. All Fire Hydrants shall conform to AWWA C502 with Storz adaptors and rain caps.
- B. Acceptable fire hydrants include American AVK Nostalgic, Clow Medallion, Mueller Centurion or Super Centurion, American Darling B62B and EJ Watermaster 5CD250.

## PART 3 EXECUTION

### 3.1 INSTALLATION OF PIPE FITTINGS

- A. **Handling and Storage:** All pipe fittings shall be carefully handled and protected against damage, impact shocks, and free fall. All handling equipment shall be acceptable to the OWNER. Fittings shall be protected against injury whenever stored at the trench site or elsewhere. No fitting shall be installed where the lining or coating show defects that may be harmful as determined by the OWNER. Such damaged lining or coating shall be repaired or a new undamaged fitting shall be furnished and installed.
- B. All fittings damaged prior to Substantial Completion shall be repaired or replaced by the CONTRACTOR.
- C. The CONTRACTOR shall inspect each fitting prior to installation to insure that there are no damaged portions.
- D. Before placement each fitting shall be thoroughly cleaned of any foreign substance, which may have collected thereon and shall be kept clean at all times thereafter. For this purpose, the openings of all pipes and fittings in the trench shall be closed during any interruption to the WORK.
- E. The openings of all pipe and specials shall be protected with suitable bulkheads to prevent unauthorized access by persons, animals, water or any undesirable substance. At all times, means shall be provided to prevent the pipe from floating.

**END OF SECTION**

**SECTION - 15120  
MISCELLANEOUS VALVES**

**PART 1 GENERAL**

**1.1 SUMMARY**

- A. Section Includes:
  - 1. Air release and vacuum relief valves.
  - 2. Automatic control valves:
    - a. Pressure relief and pressure-sustaining valves.
    - b. Pressure-reducing valves.
  
- B. Related Sections include but are not necessarily limited to:
  - 1. Skagit PUD No. 1 General Conditions.
  - 2. Division 1 - General Requirements.
  - 3. Section 15100 - Valves: Basic Requirements.

**1.2 QUALITY ASSURANCE**

- A. Referenced Standards:
  - 1. American National Standards Institute (ANSI):
    - a. B16.1, Cast-Iron Pipe Flanges and Flanged Fittings, Class 25, 125, 250, and 800.
  - 2. American Water Works Association (AWWA):
    - a. C512, Air-Release, Air/Vacuum, and Combination Air Valves for Waterworks Service.
    - b. C550, Protective Epoxy Interior Coatings for Valves and Hydrants.

**1.3 SUBMITTALS**

- A. Shop Drawings:
  - 1. See Section 01300 for requirements for the mechanics and administration of the submittal process.
  - 2. See Section 15100.

**PART 2 PRODUCTS**

**2.1 ACCEPTABLE MANUFACTURERS**

- A. Subject to compliance with the Contract Documents, the manufacturers listed under the specific valve types are acceptable.
  
- B. Submit request for substitution in accordance with Specification Section 01600.

**2.2 AIR RELEASE AND VACUUM RELIEF VALVES**

- A. General:
  - 1. Conform to AWWA C512.
  
- B. Air Release Valve (Air):
  - 1. Air release valves shall vent accumulating air while system is in service and under pressure and be of the size indicated.
  - 2. Acceptable manufacturers:
    - a. APCO.
    - b. Golden-Anderson.
    - c. Val-Matic (Valve and Manufacturing Corporation)

- d. Crispin (Multiplex Manufacturing Company)
  - e. Or approved equal.
3. Materials:
    - a. Body and cover: Cast iron or semi-steel.
    - b. Float: Stainless steel.
    - c. Linkage and trim: Stainless steel.
  4. Design requirements:
    - a. Working pressure: 250 psi.
    - b. Release 40 cfm at 10 psi differential at 250 psi line pressure.
- C. Air Vacuum Valve (AV):
1. Air and vacuum valves shall be capable of venting large quantities of air while pipelines are being filled and allowing air to re-enter while pipelines are being drained. They shall be of the size indicated, furnished with hoods and flanged or screwed ends to match piping.
  2. Acceptable manufacturers:
    - a. APCO.
    - b. Golden-Anderson.
    - c. Val-Matic
    - d. Crispin (Multiplex Manufacturing Company)
    - e. Or approved equal.
  3. Materials:
    - a. Body and cover: High strength cast iron.
    - b. Float: Stainless steel, type 316.
    - c. Seat: Stainless steel, type 316.
    - d. All other moving parts: Stainless steel, type 316.
    - e. Seat washers and gaskets shall be of a material insuring water tightness with a minimum of maintenance.
    - f. All flanges shall match drilling of an ANSI/ASME B16.1, Class 125 or 250 as indicated on the plans.
  4. Design requirements:
    - a. Working pressure: 250 psi.
    - b. Capacity 5 scfm at 2 psi differential, exhausting air; 9 scfm at 5 psi differential, admitting air.
    - c. Provide gate or ball isolation valve.
    - d. Flush accessories:
      - 1) Blow-off valve.
      - 2) Clear water inlet valve.
      - 3) Hose and quick connect coupling.
- D. Combination Air Release Valves (AVAR) shall be manufactured in accordance with the latest revision of AWWA C512. Valves shall be manufactured to meet the following:
1. Combine the characteristics of air and vacuum valves and air-release valves by exhausting accumulated air in systems under pressure and releasing or re-admitting large quantities of air while a system is being filled or drained, respectively.
  2. The cross sectional area of the discharge orifice must be equal to the cross sectional area of the valve inlet size.
  3. Working pressure of 300 psi.
  4. Release 10 cfm at 10 psi differential at 250 psi line pressure.
  5. Air vacuum capacity 9 scfm at 5 psi differential from atmospheric.
  6. Valves shall be combination body.
  7. All flanges shall match an ANSI/ASME B16.1 Class 125 or 250 drilling pattern as indicated on the plans.

E. Materials

1. Body and cover: ASTM A126 Gr. B cast iron
2. Needle and Seat: Buna-N
3. Float, linkage and hardware: Type 316 or 304 Stainless steel
4. Plug: Brass
5. Coating: Paint exterior with corrosion resistant primer

**2.3 ACCESSORIES**

- A. Furnish any accessories required to provide a completely operable valve.

**2.4 CORPORATION STOPS**

- A. HDPE pipe saddles for corporation stops for services and combination air valves shall be HDPE electrofused transition saddles.
- B. Unless otherwise indicated, corporation stops shall be made of solid (no lead) brass for key operation, with screwed ends with corporation thread or iron pipe thread, as required. Corporation stops shall be suitable for pressure of 250 psi minimum unless otherwise shown.
- C. Manufactures, or approved equal:
1. Ford Meter Box Company, Inc.
  2. James Jones Company (Watts, ACV).
  3. Mueller Company (Grinnell Corporation).

**2.5 FABRICATION**

- A. Completely shop assemble unit including any interconnecting piping, speed control valves, control isolation valves and electrical components.
- B. Provide internal epoxy coating suitable for potable water for all iron body valves in accordance with AWWA C550.

**2.6 MAINTENANCE MATERIALS**

- A. Provide one set of any special tools or wrenches required for operation or maintenance for each type valve.

**PART 3 EXECUTION**

**3.1 INSTALLATION**

- A. General:
1. All valves shall be installed in accordance with manufacturer's printed installation instructions and with provisions of Section 15100.
- B. Air Release, Vacuum Relief, Pressure Reducing, and Pressure Relief Valves:
1. Pipe exhaust to a suitable disposal point.
  2. Where exhausted to a trapped floor drain, terminate exhaust line 6 IN minimum above floor.



**3.2 FIELD QUALITY CONTROL**

- A. Clean, inspect, and operate valve to ensure all parts are operable and valve seats properly.
- B. Check and adjust valves and accessories in accordance with manufacturer's instructions and place into operation.

**END OF SECTION**

**SECTION - 15950  
WATER PIPELINE TESTING AND DISINFECTION**

**PART 1 GENERAL**

**1.1 THE REQUIREMENT**

- A. The Contractor shall perform flushing, testing and disinfection of all pipelines and appurtenant piping for potable water, complete, in accordance with the Contract Documents.

**1.2 REFERENCE SPECIFICATIONS, CODES, AND STANDARDS**

- A. Skagit County PUD Standards
  - 1. See Skagit County PUD website:  
<https://www.skagitpud.org/home/showpublisheddocument/2420/638138813501270000e>.

**1.3 CONTRACTOR SUBMITTALS**

- A. Submit in accordance with Section 01300.
- B. A proposed plan and schedule for water conveyance, cleaning, pressure testing, with disinfection, and water disposal. The plan shall include qualifications of personnel performing this work.

**PART 2 PRODUCTS**

**2.1 MATERIALS REQUIREMENTS**

- A. All test equipment, temporary valves, bulkheads, pipes or other water control equipment and materials shall be selected and furnished by the Contractor subject to the Owner's review. No materials shall be used which would be injurious to the construction or its future function.
- B. The Contractor shall provide hypochlorite and other chlorination chemicals for disinfection. The Owner will provide personnel to supervise disinfection of the pipelines. The Contractor shall safely treat and dispose of disinfecting wastewater.

**2.2 MIXING DISINFECTANT**

- A. Prepare "stock" solution by mixing in Contractor-supplied vessels any of the following as described below. The purpose of the stock solution is to facilitate mixing and dilution to ensure a uniform disinfecting solution. The Contractor will be required to mix a stock solution of chlorine to mix a final (dilute) disinfecting solution.
  - 1. The Contractor may provide calcium hypochlorite conforming to AWWA B300 or sodium hypochlorite conforming to AWWA B303 powder or liquid and water mixture.
- B. Use following portions of hypochlorite or chlorine to water:
  - 1. Calcium Hypochlorite (65 to 70 Percent Cl): 1 pound per 7.5 gallons water.
    - a. If calcium hypochlorite is used, first mix dry powder with water to make a thick paste, and then thin to a 1 percent solution (10,000 ppm chlorine).
  - 2. Sodium Hypochlorite (5.25 Percent Cl): 1 gallon per 4.25 gallons water.
    - a. If sodium hypochlorite procedure is used, dilute the liquid with water to obtain a 1 percent solution.

## **PART 3 EXECUTION**

### **3.1 GENERAL**

- A. The Contractor shall pressure test and disinfect the pipeline.
- B. Unless otherwise indicated, water for testing and disinfecting water pipelines will be furnished by the Owner from existing water lines; however, the Contractor shall make all necessary provisions for conveying the water from the Owner-designated source to the points of use.
- C. Prior to pressure testing and disinfection, all pipelines shall be cleaned and washed or flushed.
- D. All pressure pipelines and valves shall be tested.
- E. Disinfection shall be accomplished by chlorination. All chlorinating and testing operations shall be performed in the presence of the Owner.
- F. Disinfection operations shall be scheduled by the Contractor as late as possible during the contract time period so as to assure the maximum degree of sterility of the facilities at the time the Work is accepted by the Owner. Bacteriological sampling will be performed by the District Inspector and the samples furnished to the Owner for testing. Results of the bacteriological testing shall be satisfactory to the State Department of Health or other appropriate regulatory agency.
- G. Corporation stops with copper pipe stubs shall be installed at selected points along the pipeline for use as sampling stations and points to apply test pressure. The sampling stations shall be removed after bacterial tests and pressure tests are completed unless the station will be used for a new water service lateral. The Contractor shall complete any excavating required for removal of the sample stations.

### **3.2 FLUSHING AND CLEANING OF PIPELINES**

- A. The Contractor shall keep pipelines as clean as possible during all phases of construction and every effort shall be made to keep animals and trench water out and prevent material from falling, washing, or blowing into the pipelines. All openings to the pipelines shall be plugged when not in use.
- B. Prior to application of disinfectants, clean pipelines of loose and suspended material.
- C. The pipelines shall be flushed with potable water until clear of suspended solids and color.

### **3.3 HYDROSTATIC TESTING OF PIPELINES**

- A. The Contractor shall furnish and assemble all testing equipment including measuring devices and shall furnish all labor required for testing.
- B. The Contractor shall test all pipelines either in sections or as a unit not to exceed 1,500 lineal feet, not including branches for hydrant runs.
- C. No section of the pipeline shall be tested until all field-placed concrete has attained an age of 14 days. The test shall be made by closing valves when available, or by placing temporary bulkheads in the pipe and filling the line slowly with water. The Contractor shall be responsible for ascertaining that all test bulkheads are suitably restrained to resist the thrust of the test pressure without damage to, or movement of, the adjacent pipe. Any unharnessed sleeve-type couplings, expansion joints, or other sliding joints shall be restrained or suitably anchored prior to the test, to avoid movement and damage to piping and equipment. The Contractor shall provide sufficient temporary air tappings in the pipelines to allow for evacuation of all entrapped air in each pipe segment to be tested. After completion of the tests, such taps shall be permanently plugged. Care shall be taken to see that all air vents are open during filling.

- D. The pipeline shall be filled at a rate which will not cause any surges or exceed the rate at which the air can be released through the air valves at a reasonable velocity and all the air within the pipeline shall be properly purged. After the pipeline or section thereof has been filled, it shall be allowed to stand under a pressure for a sufficient length of time to allow the escape of air from any air pockets. During this period, bulkheads, valves, and connections shall be examined for leaks. If leaks are found, corrective measures satisfactory to the Owner shall be taken.
- E. Hydrostatic Testing of Ductile Iron/PVC Pipe:
1. Before any section of the pipe is filled with water, the Contractor shall inspect the piping and shall remove all foreign material.
  2. The Contractor shall notify the Owner 10 working days prior to testing.
  3. The Contractor shall not operate any valves on the Owner's existing system.
  4. The Contractor shall furnish the necessary pumps, shutoff valves, check valves, plumbing, meter, two pressure gages with petcocks, and other equipment necessary to complete the hydrostatic testing. The Contractor shall also furnish and install any temporary bulkheads, blocking or anchorage necessary to hold the pipe in position during the test. The Owner will furnish a pressure recorder. No direct connections to active water mains will be allowed for supplying makeup water.
  5. The Contractor shall open the valves at the high points to release air.
  6. The hydrostatic test shall consist of holding the test pressure on the pipeline for a specified period of time. All visible leaks shall be repaired in a manner acceptable to the Owner.
  7. Leakage testing shall be in accordance with AWWA M55 and ASTM F2164.
  8. Test pressure shall be 1.5 times the working pressure. The pipeline shall be filled and pressurized for a period of 2 hours.
  9. Acceptance Criteria: If the pressure remains steady (within 5 psi of the target value) for one hour, leakage is not indicated.
- F. Pipelines that fail to pass the prescribed leakage test will be considered defective Work, and the Contractor shall determine the cause of the leakage, shall take corrective measures necessary to repair the leaks, and shall retest the pipelines. All leaks and defects shall be corrected by the Contractor to the satisfaction of the Owner at no cost to the Owner. Any exposed joint showing visible leakage shall be repaired to zero leakage regardless of test results.
- G. Notify the Owner at least 48 hours in advance of draining test water from pipelines into a sanitary sewer or storm drain. The Contractor will notify the proper agencies to obtain permission for use of the sewer or storm drain system.

### **3.4 DISINFECTING PIPELINES**

- A. General: All potable water pipelines shall be disinfected in accordance with the requirements of Skagit County PUD. Waterlines can be disinfected with the tablet/granule method (calcium hypochlorite) or the continuous-feed/liquid chlorine method (sodium hypochlorite) of chlorination.
- B. Retention Period: Chlorinated water shall be retained in the pipeline long enough to destroy all non-spore-forming bacteria. After the Skagit PUD inspector confirms the initial chlorine concentration, the waterline shall have a minimum contact time of 24 hours (but not more than 48 hours). After the chlorine-treated water has been retained for the required time, the total chlorine residual at the pipeline extremities and at other representative points shall be at least 25 mg/l.
- C. Chlorinating Valves: During the process of chlorinating the pipelines, all valves and other appurtenances shall be operated while the pipeline is filled with the heavily-chlorinated water.
- D. Sampling Ports: The Contractor shall provide sampling ports along the pipeline as defined on AWWA C651. Taps may be made at blind flanges attached to blowoffs, manways and air valves to help facilitate the spacing requirement.

- E. Final Flushing: After the applicable retention period, the heavily chlorinated water shall be flushed from the pipeline until chlorine measurements show that the concentration in the water leaving the pipeline is no higher than that generally prevailing in the system or is acceptable for domestic use. A reducing agent will be applied to the water by the Contractor to neutralize thoroughly the chlorine residual remaining in the water prior to discharge. The Contractor shall pay particular attention to the requirements for neutralizing and the proper disposal of treated (chlorinated) water. Contractor shall prepare and submit to the Owner for favorable review a plan for disposing of treated water prior to performing any disinfection. The Owner has found dechlorination with ascorbic acid (Vitamin C) to be effective. The Contractor shall not dispose of treated water directly to any water course or natural drainage channel.
- F. Bacteriological Testing: After final flushing and before the pipeline is placed in service, a sample, or samples will be collected by the District Inspector from the end of the line or at other point(s) as determined by the Owner, and will be provided to the Owner for testing for bacteriological quality in accordance with the requirements of the State Department of Health or other appropriate regulatory agency. For this purpose the pipe shall be re-filled with fresh potable water and left for a period of 16 hours before any sample is collected. Should the initial disinfection treatment fail to produce satisfactory bacteriological test results, the disinfection procedure shall be repeated until acceptable results are obtained. The Contractor shall allow 3 days in his schedule for the Owner's water analysis.

### **3.5 CONNECTIONS TO EXISTING SYSTEM**

- A. Pipe systems meeting disinfection and testing requirements will be approved for connection to existing systems in use. Approved systems shall be connected by District crews following a 3-day notice to make requested connections.

**END OF SECTION**

**APPENDIX A**  
**PREVAILING WAGE**

State of Washington  
 Department of Labor & Industries  
 Prevailing Wage Section - Telephone 360-902-5335  
 PO Box 44540, Olympia, WA 98504-4540

**Washington State Prevailing Wage**

The PREVAILING WAGES listed here include both the hourly wage rate and the hourly rate of fringe benefits. On public works projects, worker's wage and benefit rates must add to not less than this total. A brief description of overtime calculation requirements are provided on the Benefit Code Key.

**Journey Level Prevailing Wage Rates for the Effective Date: 8/6/2024**

<a href="#">County</a>	<a href="#">Trade</a>	<a href="#">Job Classification</a>	<a href="#">Wage</a>	Holiday	Overtime	Note	*Risk Class
Skagit	<a href="#">Asbestos Abatement Workers</a>	Journey Level	\$59.07	<a href="#">5D</a>	<a href="#">1H</a>		<a href="#">View</a>
Skagit	<a href="#">Boilermakers</a>	Journey Level	\$74.29	<a href="#">5N</a>	<a href="#">1C</a>		<a href="#">View</a>
Skagit	<a href="#">Brick Mason</a>	Journey Level	\$69.07	<a href="#">7E</a>	<a href="#">1N</a>		<a href="#">View</a>
Skagit	<a href="#">Brick Mason</a>	Pointer-Caulker-Cleaner	\$69.07	<a href="#">7E</a>	<a href="#">1N</a>		<a href="#">View</a>
Skagit	<a href="#">Building Service Employees</a>	Janitor	\$16.28		<a href="#">1</a>		<a href="#">View</a>
Skagit	<a href="#">Building Service Employees</a>	Shampooer	\$16.28		<a href="#">1</a>		<a href="#">View</a>
Skagit	<a href="#">Building Service Employees</a>	Waxer	\$16.28		<a href="#">1</a>		<a href="#">View</a>
Skagit	<a href="#">Building Service Employees</a>	Window Cleaner	\$16.28		<a href="#">1</a>		<a href="#">View</a>
Skagit	<a href="#">Cabinet Makers (In Shop)</a>	Journey Level	\$18.85		<a href="#">1</a>		<a href="#">View</a>
Skagit	<a href="#">Carpenters</a>	Acoustical Worker	\$74.96	<a href="#">15J</a>	<a href="#">4C</a>		<a href="#">View</a>
Skagit	<a href="#">Carpenters</a>	Bridge, Dock And Wharf Carpenters	\$74.96	<a href="#">15J</a>	<a href="#">4C</a>		<a href="#">View</a>
Skagit	<a href="#">Carpenters</a>	Floor Layer & Floor Finisher	\$74.96	<a href="#">15J</a>	<a href="#">4C</a>		<a href="#">View</a>
Skagit	<a href="#">Carpenters</a>	Journey Level	\$74.96	<a href="#">15J</a>	<a href="#">4C</a>		<a href="#">View</a>
Skagit	<a href="#">Carpenters</a>	Scaffold Erector	\$74.96	<a href="#">15J</a>	<a href="#">4C</a>		<a href="#">View</a>
Skagit	<a href="#">Cement Masons</a>	Application of all Composition Mastic	\$72.87	<a href="#">15J</a>	<a href="#">4U</a>		<a href="#">View</a>
Skagit	<a href="#">Cement Masons</a>	Application of all Epoxy Material	\$72.37	<a href="#">15J</a>	<a href="#">4U</a>		<a href="#">View</a>
Skagit	<a href="#">Cement Masons</a>	Application of all Plastic Material	\$72.87	<a href="#">15J</a>	<a href="#">4U</a>		<a href="#">View</a>
Skagit	<a href="#">Cement Masons</a>	Application of Sealing Compound	\$72.37	<a href="#">15J</a>	<a href="#">4U</a>		<a href="#">View</a>
Skagit	<a href="#">Cement Masons</a>	Application of Underlayment	\$72.87	<a href="#">15J</a>	<a href="#">4U</a>		<a href="#">View</a>
Skagit	<a href="#">Cement Masons</a>	Building General	\$72.37	<a href="#">15J</a>	<a href="#">4U</a>		<a href="#">View</a>
Skagit	<a href="#">Cement Masons</a>	Composition or Kalman Floors	\$72.87	<a href="#">15J</a>	<a href="#">4U</a>		<a href="#">View</a>
Skagit	<a href="#">Cement Masons</a>	Concrete Paving	\$72.37	<a href="#">15J</a>	<a href="#">4U</a>		<a href="#">View</a>
Skagit	<a href="#">Cement Masons</a>	Curb & Gutter Machine	\$72.87	<a href="#">15J</a>	<a href="#">4U</a>		<a href="#">View</a>
Skagit	<a href="#">Cement Masons</a>	Curb & Gutter, Sidewalks	\$72.37	<a href="#">15J</a>	<a href="#">4U</a>		<a href="#">View</a>
Skagit	<a href="#">Cement Masons</a>	Curing Concrete	\$72.37	<a href="#">15J</a>	<a href="#">4U</a>		<a href="#">View</a>
Skagit	<a href="#">Cement Masons</a>	Finish Colored Concrete	\$72.87	<a href="#">15J</a>	<a href="#">4U</a>		<a href="#">View</a>
Skagit	<a href="#">Cement Masons</a>	Floor Grinding	\$72.87	<a href="#">15J</a>	<a href="#">4U</a>		<a href="#">View</a>
Skagit	<a href="#">Cement Masons</a>	Floor Grinding/Polisher	\$72.37	<a href="#">15J</a>	<a href="#">4U</a>		<a href="#">View</a>
Skagit	<a href="#">Cement Masons</a>	Green Concrete Saw, self-powered	\$72.87	<a href="#">15J</a>	<a href="#">4U</a>		<a href="#">View</a>
Skagit	<a href="#">Cement Masons</a>	Grouting of all Plates	\$72.37	<a href="#">15J</a>	<a href="#">4U</a>		<a href="#">View</a>
Skagit	<a href="#">Cement Masons</a>	Grouting of all Tilt-up Panels	\$72.37	<a href="#">15J</a>	<a href="#">4U</a>		<a href="#">View</a>
Skagit	<a href="#">Cement Masons</a>	Gunite Nozzleman	\$72.87	<a href="#">15J</a>	<a href="#">4U</a>		<a href="#">View</a>
Skagit	<a href="#">Cement Masons</a>	Hand Powered Grinder	\$72.87	<a href="#">15J</a>	<a href="#">4U</a>		<a href="#">View</a>
Skagit	<a href="#">Cement Masons</a>	Journey Level	\$72.37	<a href="#">15J</a>	<a href="#">4U</a>		<a href="#">View</a>

Skagit	<a href="#">Cement Masons</a>	Patching Concrete	\$72.37	<a href="#">15J</a>	<a href="#">4U</a>		<a href="#">View</a>
Skagit	<a href="#">Cement Masons</a>	Pneumatic Power Tools	\$72.87	<a href="#">15J</a>	<a href="#">4U</a>		<a href="#">View</a>
Skagit	<a href="#">Cement Masons</a>	Power Chipping & Brushing	\$72.87	<a href="#">15J</a>	<a href="#">4U</a>		<a href="#">View</a>
Skagit	<a href="#">Cement Masons</a>	Sand Blasting Architectural Finish	\$72.87	<a href="#">15J</a>	<a href="#">4U</a>		<a href="#">View</a>
Skagit	<a href="#">Cement Masons</a>	Screed & Rodding Machine	\$72.87	<a href="#">15J</a>	<a href="#">4U</a>		<a href="#">View</a>
Skagit	<a href="#">Cement Masons</a>	Spackling or Skim Coat Concrete	\$72.37	<a href="#">15J</a>	<a href="#">4U</a>		<a href="#">View</a>
Skagit	<a href="#">Cement Masons</a>	Troweling Machine Operator	\$72.87	<a href="#">15J</a>	<a href="#">4U</a>		<a href="#">View</a>
Skagit	<a href="#">Cement Masons</a>	Troweling Machine Operator on Colored Slabs	\$72.87	<a href="#">15J</a>	<a href="#">4U</a>		<a href="#">View</a>
Skagit	<a href="#">Cement Masons</a>	Tunnel Workers	\$72.87	<a href="#">15J</a>	<a href="#">4U</a>		<a href="#">View</a>
Skagit	<a href="#">Divers &amp; Tenders</a>	Bell/Vehicle or Submersible Operator (Not Under Pressure)	\$129.71	<a href="#">15J</a>	<a href="#">4C</a>		<a href="#">View</a>
Skagit	<a href="#">Divers &amp; Tenders</a>	Dive Supervisor/Master	\$93.94	<a href="#">15J</a>	<a href="#">4C</a>		<a href="#">View</a>
Skagit	<a href="#">Divers &amp; Tenders</a>	Diver	\$129.71	<a href="#">15J</a>	<a href="#">4C</a>	<a href="#">8V</a>	<a href="#">View</a>
Skagit	<a href="#">Divers &amp; Tenders</a>	Diver On Standby	\$88.94	<a href="#">15J</a>	<a href="#">4C</a>		<a href="#">View</a>
Skagit	<a href="#">Divers &amp; Tenders</a>	Diver Tender	\$80.82	<a href="#">15J</a>	<a href="#">4C</a>		<a href="#">View</a>
Skagit	<a href="#">Divers &amp; Tenders</a>	Hyperbaric Worker - Compressed Air Worker 0-30.00 PSI	\$93.26	<a href="#">15J</a>	<a href="#">4C</a>		<a href="#">View</a>
Skagit	<a href="#">Divers &amp; Tenders</a>	Hyperbaric Worker - Compressed Air Worker 30.01 - 44.00 PSI	\$98.26	<a href="#">15J</a>	<a href="#">4C</a>		<a href="#">View</a>
Skagit	<a href="#">Divers &amp; Tenders</a>	Hyperbaric Worker - Compressed Air Worker 44.01 - 54.00 PSI	\$102.26	<a href="#">15J</a>	<a href="#">4C</a>		<a href="#">View</a>
Skagit	<a href="#">Divers &amp; Tenders</a>	Hyperbaric Worker - Compressed Air Worker 54.01 - 60.00 PSI	\$107.26	<a href="#">15J</a>	<a href="#">4C</a>		<a href="#">View</a>
Skagit	<a href="#">Divers &amp; Tenders</a>	Hyperbaric Worker - Compressed Air Worker 60.01 - 64.00 PSI	\$109.76	<a href="#">15J</a>	<a href="#">4C</a>		<a href="#">View</a>
Skagit	<a href="#">Divers &amp; Tenders</a>	Hyperbaric Worker - Compressed Air Worker 64.01 - 68.00 PSI	\$114.76	<a href="#">15J</a>	<a href="#">4C</a>		<a href="#">View</a>
Skagit	<a href="#">Divers &amp; Tenders</a>	Hyperbaric Worker - Compressed Air Worker 68.01 - 70.00 PSI	\$116.76	<a href="#">15J</a>	<a href="#">4C</a>		<a href="#">View</a>
Skagit	<a href="#">Divers &amp; Tenders</a>	Hyperbaric Worker - Compressed Air Worker 70.01 - 72.00 PSI	\$118.76	<a href="#">15J</a>	<a href="#">4C</a>		<a href="#">View</a>
Skagit	<a href="#">Divers &amp; Tenders</a>	Hyperbaric Worker - Compressed Air Worker 72.01 - 74.00 PSI	\$120.76	<a href="#">15J</a>	<a href="#">4C</a>		<a href="#">View</a>
Skagit	<a href="#">Divers &amp; Tenders</a>	Manifold Operator	\$80.82	<a href="#">15J</a>	<a href="#">4C</a>		<a href="#">View</a>
Skagit	<a href="#">Divers &amp; Tenders</a>	Manifold Operator Mixed Gas	\$85.82	<a href="#">15J</a>	<a href="#">4C</a>		<a href="#">View</a>
Skagit	<a href="#">Divers &amp; Tenders</a>	Remote Operated Vehicle Operator/Technician	\$80.82	<a href="#">15J</a>	<a href="#">4C</a>		<a href="#">View</a>
Skagit	<a href="#">Divers &amp; Tenders</a>	Remote Operated Vehicle Tender	\$75.41	<a href="#">15J</a>	<a href="#">4C</a>		<a href="#">View</a>
Skagit	<a href="#">Dredge Workers</a>	Assistant Engineer	\$79.62	<a href="#">5D</a>	<a href="#">3F</a>		<a href="#">View</a>
Skagit	<a href="#">Dredge Workers</a>	Assistant Mate (Deckhand)	\$79.01	<a href="#">5D</a>	<a href="#">3F</a>		<a href="#">View</a>
Skagit	<a href="#">Dredge Workers</a>	Boatmen	\$79.62	<a href="#">5D</a>	<a href="#">3F</a>		<a href="#">View</a>
Skagit	<a href="#">Dredge Workers</a>	Engineer Welder	\$81.15	<a href="#">5D</a>	<a href="#">3F</a>		<a href="#">View</a>
Skagit	<a href="#">Dredge Workers</a>	Leverman, Hydraulic	\$82.77	<a href="#">5D</a>	<a href="#">3F</a>		<a href="#">View</a>
Skagit	<a href="#">Dredge Workers</a>	Mates	\$79.62	<a href="#">5D</a>	<a href="#">3F</a>		<a href="#">View</a>
Skagit	<a href="#">Dredge Workers</a>	Oiler	\$79.01	<a href="#">5D</a>	<a href="#">3F</a>		<a href="#">View</a>
Skagit	<a href="#">Drywall Applicator</a>	Journey Level	\$75.73	<a href="#">15O</a>	<a href="#">11S</a>		<a href="#">View</a>
Skagit	<a href="#">Drywall Tapers</a>	Journey Level	\$75.73	<a href="#">15O</a>	<a href="#">11S</a>		<a href="#">View</a>
Skagit	<a href="#">Electrical Fixture Maintenance Workers</a>	Journey Level	\$21.48		<a href="#">1</a>		<a href="#">View</a>
Skagit	<a href="#">Electricians - Inside</a>	Cable Splicer	\$90.40	<a href="#">7H</a>	<a href="#">1E</a>		<a href="#">View</a>
Skagit	<a href="#">Electricians - Inside</a>	Construction Stock Person	\$42.59	<a href="#">7H</a>	<a href="#">1D</a>		<a href="#">View</a>
Skagit	<a href="#">Electricians - Inside</a>	Journey Level	\$84.73	<a href="#">7H</a>	<a href="#">1E</a>		<a href="#">View</a>



Skagit	<a href="#">Electricians - Motor Shop</a>	Craftsman	\$16.28		<u>1</u>		<a href="#">View</a>
Skagit	<a href="#">Electricians - Motor Shop</a>	Journey Level	\$16.28		<u>1</u>		<a href="#">View</a>
Skagit	<a href="#">Electricians - Powerline Construction</a>	Cable Splicer	\$93.00	<u>5A</u>	<u>4D</u>		<a href="#">View</a>
Skagit	<a href="#">Electricians - Powerline Construction</a>	Certified Line Welder	\$85.42	<u>5A</u>	<u>4D</u>		<a href="#">View</a>
Skagit	<a href="#">Electricians - Powerline Construction</a>	Groundperson	\$55.27	<u>5A</u>	<u>4D</u>		<a href="#">View</a>
Skagit	<a href="#">Electricians - Powerline Construction</a>	Heavy Line Equipment Operator	\$85.42	<u>5A</u>	<u>4D</u>		<a href="#">View</a>
Skagit	<a href="#">Electricians - Powerline Construction</a>	Journey Level Lineperson	\$85.42	<u>5A</u>	<u>4D</u>		<a href="#">View</a>
Skagit	<a href="#">Electricians - Powerline Construction</a>	Line Equipment Operator	\$73.35	<u>5A</u>	<u>4D</u>		<a href="#">View</a>
Skagit	<a href="#">Electricians - Powerline Construction</a>	Meter Installer	\$55.27	<u>5A</u>	<u>4D</u>	<u>8W</u>	<a href="#">View</a>
Skagit	<a href="#">Electricians - Powerline Construction</a>	Pole Sprayer	\$85.42	<u>5A</u>	<u>4D</u>		<a href="#">View</a>
Skagit	<a href="#">Electricians - Powerline Construction</a>	Powderperson	\$63.50	<u>5A</u>	<u>4D</u>		<a href="#">View</a>
Skagit	<a href="#">Electronic Technicians</a>	Electronic Technicians Journey Level	\$53.94	<u>5B</u>	<u>1B</u>		<a href="#">View</a>
Skagit	<a href="#">Elevator Constructors</a>	Mechanic	\$111.26	<u>7D</u>	<u>4A</u>		<a href="#">View</a>
Skagit	<a href="#">Elevator Constructors</a>	Mechanic In Charge	\$120.27	<u>7D</u>	<u>4A</u>		<a href="#">View</a>
Skagit	<a href="#">Fabricated Precast Concrete Products</a>	Journey Level	\$16.28		<u>1</u>		<a href="#">View</a>
Skagit	<a href="#">Fabricated Precast Concrete Products</a>	Journey Level - In-Factory Work Only	\$16.28		<u>1</u>		<a href="#">View</a>
Skagit	<a href="#">Fence Erectors</a>	Fence Erector	\$50.07	<u>15J</u>	<u>11P</u>	<u>8Y</u>	<a href="#">View</a>
Skagit	<a href="#">Fence Erectors</a>	Fence Laborer	\$50.07	<u>15J</u>	<u>11P</u>	<u>8Y</u>	<a href="#">View</a>
Skagit	<a href="#">Flaggers</a>	Journey Level	\$50.07	<u>15J</u>	<u>11P</u>	<u>8Y</u>	<a href="#">View</a>
Skagit	<a href="#">Glaziers</a>	Journey Level	\$79.16	<u>7L</u>	<u>1Y</u>		<a href="#">View</a>
Skagit	<a href="#">Heat &amp; Frost Insulators And Asbestos Workers</a>	Journey Level	\$87.15	<u>15H</u>	<u>11C</u>		<a href="#">View</a>
Skagit	<a href="#">Heating Equipment Mechanics</a>	Mechanic	\$92.96	<u>7F</u>	<u>1E</u>		<a href="#">View</a>
Skagit	<a href="#">Hod Carriers &amp; Mason Tenders</a>	Journey Level	\$62.49	<u>15J</u>	<u>11P</u>	<u>8Y</u>	<a href="#">View</a>
Skagit	<a href="#">Industrial Power Vacuum Cleaner</a>	Journey Level	\$16.28		<u>1</u>		<a href="#">View</a>
Skagit	<a href="#">Inland Boatmen</a>	Boat Operator	\$61.41	<u>5B</u>	<u>1K</u>		<a href="#">View</a>
Skagit	<a href="#">Inland Boatmen</a>	Cook	\$56.48	<u>5B</u>	<u>1K</u>		<a href="#">View</a>
Skagit	<a href="#">Inland Boatmen</a>	Deckhand	\$57.48	<u>5B</u>	<u>1K</u>		<a href="#">View</a>
Skagit	<a href="#">Inland Boatmen</a>	Deckhand Engineer	\$58.81	<u>5B</u>	<u>1K</u>		<a href="#">View</a>
Skagit	<a href="#">Inland Boatmen</a>	Launch Operator	\$58.89	<u>5B</u>	<u>1K</u>		<a href="#">View</a>
Skagit	<a href="#">Inland Boatmen</a>	Mate	\$57.31	<u>5B</u>	<u>1K</u>		<a href="#">View</a>
Skagit	<a href="#">Inspection/Cleaning/Sealing Of Sewer &amp; Water Systems By Remote Control</a>	Cleaner Operator	\$49.48	<u>15M</u>	<u>11O</u>		<a href="#">View</a>
Skagit	<a href="#">Inspection/Cleaning/Sealing Of Sewer &amp; Water Systems By Remote Control</a>	Foamer Operator	\$49.48	<u>15M</u>	<u>11O</u>		<a href="#">View</a>
Skagit	<a href="#">Inspection/Cleaning/Sealing Of Sewer &amp; Water Systems By Remote Control</a>	Grout Truck Operator	\$49.48	<u>15M</u>	<u>11O</u>		<a href="#">View</a>
Skagit	<a href="#">Inspection/Cleaning/Sealing Of Sewer &amp; Water Systems By Remote Control</a>	Head Operator	\$47.41	<u>15M</u>	<u>11O</u>		<a href="#">View</a>

Skagit	<a href="#">Inspection/Cleaning/Sealing Of Sewer &amp; Water Systems By Remote Control</a>	Technician	\$41.20	<a href="#">15M</a>	<a href="#">11O</a>		<a href="#">View</a>
Skagit	<a href="#">Inspection/Cleaning/Sealing Of Sewer &amp; Water Systems By Remote Control</a>	TV Truck Operator	\$44.31	<a href="#">15M</a>	<a href="#">11O</a>		<a href="#">View</a>
Skagit	<a href="#">Insulation Applicators</a>	Journey Level	\$74.96	<a href="#">15J</a>	<a href="#">4C</a>		<a href="#">View</a>
Skagit	<a href="#">Ironworkers</a>	Journeyman	\$87.80	<a href="#">15K</a>	<a href="#">11N</a>		<a href="#">View</a>
Skagit	<a href="#">Laborers</a>	Air, Gas Or Electric Vibrating Screed	\$59.07	<a href="#">15J</a>	<a href="#">11P</a>	<a href="#">8Y</a>	<a href="#">View</a>
Skagit	<a href="#">Laborers</a>	Airtrac Drill Operator	\$60.90	<a href="#">15J</a>	<a href="#">11P</a>	<a href="#">8Y</a>	<a href="#">View</a>
Skagit	<a href="#">Laborers</a>	Ballast Regular Machine	\$59.07	<a href="#">15J</a>	<a href="#">11P</a>	<a href="#">8Y</a>	<a href="#">View</a>
Skagit	<a href="#">Laborers</a>	Batch Weighman	\$50.07	<a href="#">15J</a>	<a href="#">11P</a>	<a href="#">8Y</a>	<a href="#">View</a>
Skagit	<a href="#">Laborers</a>	Brick Pavers	\$59.07	<a href="#">15J</a>	<a href="#">11P</a>	<a href="#">8Y</a>	<a href="#">View</a>
Skagit	<a href="#">Laborers</a>	Brush Cutter	\$59.07	<a href="#">15J</a>	<a href="#">11P</a>	<a href="#">8Y</a>	<a href="#">View</a>
Skagit	<a href="#">Laborers</a>	Brush Hog Feeder	\$59.07	<a href="#">15J</a>	<a href="#">11P</a>	<a href="#">8Y</a>	<a href="#">View</a>
Skagit	<a href="#">Laborers</a>	Burner	\$59.07	<a href="#">15J</a>	<a href="#">11P</a>	<a href="#">8Y</a>	<a href="#">View</a>
Skagit	<a href="#">Laborers</a>	Caisson Worker	\$60.90	<a href="#">15J</a>	<a href="#">11P</a>	<a href="#">8Y</a>	<a href="#">View</a>
Skagit	<a href="#">Laborers</a>	Carpenter Tender	\$59.07	<a href="#">15J</a>	<a href="#">11P</a>	<a href="#">8Y</a>	<a href="#">View</a>
Skagit	<a href="#">Laborers</a>	Cement Dumper-paving	\$60.15	<a href="#">15J</a>	<a href="#">11P</a>	<a href="#">8Y</a>	<a href="#">View</a>
Skagit	<a href="#">Laborers</a>	Cement Finisher Tender	\$59.07	<a href="#">15J</a>	<a href="#">11P</a>	<a href="#">8Y</a>	<a href="#">View</a>
Skagit	<a href="#">Laborers</a>	Change House Or Dry Shack	\$59.07	<a href="#">15J</a>	<a href="#">11P</a>	<a href="#">8Y</a>	<a href="#">View</a>
Skagit	<a href="#">Laborers</a>	Chipping Gun (30 Lbs. And Over)	\$60.15	<a href="#">15J</a>	<a href="#">11P</a>	<a href="#">8Y</a>	<a href="#">View</a>
Skagit	<a href="#">Laborers</a>	Chipping Gun (Under 30 Lbs.)	\$59.07	<a href="#">15J</a>	<a href="#">11P</a>	<a href="#">8Y</a>	<a href="#">View</a>
Skagit	<a href="#">Laborers</a>	Choker Setter	\$59.07	<a href="#">15J</a>	<a href="#">11P</a>	<a href="#">8Y</a>	<a href="#">View</a>
Skagit	<a href="#">Laborers</a>	Chuck Tender	\$59.07	<a href="#">15J</a>	<a href="#">11P</a>	<a href="#">8Y</a>	<a href="#">View</a>
Skagit	<a href="#">Laborers</a>	Clary Power Spreader	\$60.15	<a href="#">15J</a>	<a href="#">11P</a>	<a href="#">8Y</a>	<a href="#">View</a>
Skagit	<a href="#">Laborers</a>	Clean-up Laborer	\$59.07	<a href="#">15J</a>	<a href="#">11P</a>	<a href="#">8Y</a>	<a href="#">View</a>
Skagit	<a href="#">Laborers</a>	Concrete Dumper/Chute Operator	\$60.15	<a href="#">15J</a>	<a href="#">11P</a>	<a href="#">8Y</a>	<a href="#">View</a>
Skagit	<a href="#">Laborers</a>	Concrete Form Stripper	\$59.07	<a href="#">15J</a>	<a href="#">11P</a>	<a href="#">8Y</a>	<a href="#">View</a>
Skagit	<a href="#">Laborers</a>	Concrete Placement Crew	\$60.15	<a href="#">15J</a>	<a href="#">11P</a>	<a href="#">8Y</a>	<a href="#">View</a>
Skagit	<a href="#">Laborers</a>	Concrete Saw Operator/Core Driller	\$60.15	<a href="#">15J</a>	<a href="#">11P</a>	<a href="#">8Y</a>	<a href="#">View</a>
Skagit	<a href="#">Laborers</a>	Crusher Feeder	\$50.07	<a href="#">15J</a>	<a href="#">11P</a>	<a href="#">8Y</a>	<a href="#">View</a>
Skagit	<a href="#">Laborers</a>	Curing Laborer	\$59.07	<a href="#">15J</a>	<a href="#">11P</a>	<a href="#">8Y</a>	<a href="#">View</a>
Skagit	<a href="#">Laborers</a>	Demolition: Wrecking & Moving (Incl. Charred Material)	\$59.07	<a href="#">15J</a>	<a href="#">11P</a>	<a href="#">8Y</a>	<a href="#">View</a>
Skagit	<a href="#">Laborers</a>	Ditch Digger	\$59.07	<a href="#">15J</a>	<a href="#">11P</a>	<a href="#">8Y</a>	<a href="#">View</a>
Skagit	<a href="#">Laborers</a>	Diver	\$60.90	<a href="#">15J</a>	<a href="#">11P</a>	<a href="#">8Y</a>	<a href="#">View</a>
Skagit	<a href="#">Laborers</a>	Drill Operator (Hydraulic, Diamond)	\$60.15	<a href="#">15J</a>	<a href="#">11P</a>	<a href="#">8Y</a>	<a href="#">View</a>
Skagit	<a href="#">Laborers</a>	Dry Stack Walls	\$59.07	<a href="#">15J</a>	<a href="#">11P</a>	<a href="#">8Y</a>	<a href="#">View</a>
Skagit	<a href="#">Laborers</a>	Dump Person	\$59.07	<a href="#">15J</a>	<a href="#">11P</a>	<a href="#">8Y</a>	<a href="#">View</a>
Skagit	<a href="#">Laborers</a>	Epoxy Technician	\$59.07	<a href="#">15J</a>	<a href="#">11P</a>	<a href="#">8Y</a>	<a href="#">View</a>
Skagit	<a href="#">Laborers</a>	Erosion Control Worker	\$59.07	<a href="#">15J</a>	<a href="#">11P</a>	<a href="#">8Y</a>	<a href="#">View</a>
Skagit	<a href="#">Laborers</a>	Faller & Bucker Chain Saw	\$60.15	<a href="#">15J</a>	<a href="#">11P</a>	<a href="#">8Y</a>	<a href="#">View</a>
Skagit	<a href="#">Laborers</a>	Fine Graders	\$59.07	<a href="#">15J</a>	<a href="#">11P</a>	<a href="#">8Y</a>	<a href="#">View</a>
Skagit	<a href="#">Laborers</a>	Firewatch	\$50.07	<a href="#">15J</a>	<a href="#">11P</a>	<a href="#">8Y</a>	<a href="#">View</a>
Skagit	<a href="#">Laborers</a>	Form Setter	\$60.15	<a href="#">15J</a>	<a href="#">11P</a>	<a href="#">8Y</a>	<a href="#">View</a>
Skagit	<a href="#">Laborers</a>	Gabian Basket Builders	\$59.07	<a href="#">15J</a>	<a href="#">11P</a>	<a href="#">8Y</a>	<a href="#">View</a>
Skagit	<a href="#">Laborers</a>	General Laborer	\$59.07	<a href="#">15J</a>	<a href="#">11P</a>	<a href="#">8Y</a>	<a href="#">View</a>
Skagit	<a href="#">Laborers</a>	Grade Checker & Transit Person	\$62.49	<a href="#">15J</a>	<a href="#">11P</a>	<a href="#">8Y</a>	<a href="#">View</a>

Skagit	<a href="#">Laborers</a>	Grinders	\$59.07	<a href="#">15J</a>	<a href="#">11P</a>	<a href="#">8Y</a>	<a href="#">View</a>
Skagit	<a href="#">Laborers</a>	Grout Machine Tender	\$59.07	<a href="#">15J</a>	<a href="#">11P</a>	<a href="#">8Y</a>	<a href="#">View</a>
Skagit	<a href="#">Laborers</a>	Groutmen (Pressure) Including Post Tension Beams	\$60.15	<a href="#">15J</a>	<a href="#">11P</a>	<a href="#">8Y</a>	<a href="#">View</a>
Skagit	<a href="#">Laborers</a>	Guardrail Erector	\$59.07	<a href="#">15J</a>	<a href="#">11P</a>	<a href="#">8Y</a>	<a href="#">View</a>
Skagit	<a href="#">Laborers</a>	Hazardous Waste Worker (Level A)	\$60.90	<a href="#">15J</a>	<a href="#">11P</a>	<a href="#">8Y</a>	<a href="#">View</a>
Skagit	<a href="#">Laborers</a>	Hazardous Waste Worker (Level B)	\$60.15	<a href="#">15J</a>	<a href="#">11P</a>	<a href="#">8Y</a>	<a href="#">View</a>
Skagit	<a href="#">Laborers</a>	Hazardous Waste Worker (Level C)	\$59.07	<a href="#">15J</a>	<a href="#">11P</a>	<a href="#">8Y</a>	<a href="#">View</a>
Skagit	<a href="#">Laborers</a>	High Scaler	\$60.90	<a href="#">15J</a>	<a href="#">11P</a>	<a href="#">8Y</a>	<a href="#">View</a>
Skagit	<a href="#">Laborers</a>	Jackhammer	\$60.15	<a href="#">15J</a>	<a href="#">11P</a>	<a href="#">8Y</a>	<a href="#">View</a>
Skagit	<a href="#">Laborers</a>	Laserbeam Operator	\$60.15	<a href="#">15J</a>	<a href="#">11P</a>	<a href="#">8Y</a>	<a href="#">View</a>
Skagit	<a href="#">Laborers</a>	Maintenance Person	\$59.07	<a href="#">15J</a>	<a href="#">11P</a>	<a href="#">8Y</a>	<a href="#">View</a>
Skagit	<a href="#">Laborers</a>	Manhole Builder-Mudman	\$60.15	<a href="#">15J</a>	<a href="#">11P</a>	<a href="#">8Y</a>	<a href="#">View</a>
Skagit	<a href="#">Laborers</a>	Material Yard Person	\$59.07	<a href="#">15J</a>	<a href="#">11P</a>	<a href="#">8Y</a>	<a href="#">View</a>
Skagit	<a href="#">Laborers</a>	Mold Abatement Worker	\$59.07	<a href="#">15J</a>	<a href="#">11P</a>	<a href="#">8Y</a>	<a href="#">View</a>
Skagit	<a href="#">Laborers</a>	Motorman-Dinky Locomotive	\$62.59	<a href="#">15J</a>	<a href="#">11P</a>	<a href="#">8Y</a>	<a href="#">View</a>
Skagit	<a href="#">Laborers</a>	nozzleman (concrete pump, green cutter when using combination of high pressure air & water on concrete & rock, sandblast, gunite, shotcrete, water blaster, vacuum blaster)	\$62.49	<a href="#">15J</a>	<a href="#">11P</a>	<a href="#">8Y</a>	<a href="#">View</a>
Skagit	<a href="#">Laborers</a>	Pavement Breaker	\$60.15	<a href="#">15J</a>	<a href="#">11P</a>	<a href="#">8Y</a>	<a href="#">View</a>
Skagit	<a href="#">Laborers</a>	Pilot Car	\$50.07	<a href="#">15J</a>	<a href="#">11P</a>	<a href="#">8Y</a>	<a href="#">View</a>
Skagit	<a href="#">Laborers</a>	Pipe Layer (Lead)	\$62.49	<a href="#">15J</a>	<a href="#">11P</a>	<a href="#">8Y</a>	<a href="#">View</a>
Skagit	<a href="#">Laborers</a>	Pipe Layer/Tailor	\$60.15	<a href="#">15J</a>	<a href="#">11P</a>	<a href="#">8Y</a>	<a href="#">View</a>
Skagit	<a href="#">Laborers</a>	Pipe Pot Tender	\$60.15	<a href="#">15J</a>	<a href="#">11P</a>	<a href="#">8Y</a>	<a href="#">View</a>
Skagit	<a href="#">Laborers</a>	Pipe Reliner	\$60.15	<a href="#">15J</a>	<a href="#">11P</a>	<a href="#">8Y</a>	<a href="#">View</a>
Skagit	<a href="#">Laborers</a>	Pipe Wrapper	\$60.15	<a href="#">15J</a>	<a href="#">11P</a>	<a href="#">8Y</a>	<a href="#">View</a>
Skagit	<a href="#">Laborers</a>	Pot Tender	\$59.07	<a href="#">15J</a>	<a href="#">11P</a>	<a href="#">8Y</a>	<a href="#">View</a>
Skagit	<a href="#">Laborers</a>	Powderman	\$60.90	<a href="#">15J</a>	<a href="#">11P</a>	<a href="#">8Y</a>	<a href="#">View</a>
Skagit	<a href="#">Laborers</a>	Powderman's Helper	\$59.07	<a href="#">15J</a>	<a href="#">11P</a>	<a href="#">8Y</a>	<a href="#">View</a>
Skagit	<a href="#">Laborers</a>	Power Jacks	\$60.15	<a href="#">15J</a>	<a href="#">11P</a>	<a href="#">8Y</a>	<a href="#">View</a>
Skagit	<a href="#">Laborers</a>	Railroad Spike Puller - Power	\$60.15	<a href="#">15J</a>	<a href="#">11P</a>	<a href="#">8Y</a>	<a href="#">View</a>
Skagit	<a href="#">Laborers</a>	Raker - Asphalt	\$62.49	<a href="#">15J</a>	<a href="#">11P</a>	<a href="#">8Y</a>	<a href="#">View</a>
Skagit	<a href="#">Laborers</a>	Re-timberman	\$60.90	<a href="#">15J</a>	<a href="#">11P</a>	<a href="#">8Y</a>	<a href="#">View</a>
Skagit	<a href="#">Laborers</a>	Remote Equipment Operator	\$60.15	<a href="#">15J</a>	<a href="#">11P</a>	<a href="#">8Y</a>	<a href="#">View</a>
Skagit	<a href="#">Laborers</a>	Rigger/Signal Person	\$60.15	<a href="#">15J</a>	<a href="#">11P</a>	<a href="#">8Y</a>	<a href="#">View</a>
Skagit	<a href="#">Laborers</a>	Rip Rap Person	\$59.07	<a href="#">15J</a>	<a href="#">11P</a>	<a href="#">8Y</a>	<a href="#">View</a>
Skagit	<a href="#">Laborers</a>	Rivet Buster	\$60.15	<a href="#">15J</a>	<a href="#">11P</a>	<a href="#">8Y</a>	<a href="#">View</a>
Skagit	<a href="#">Laborers</a>	Rodder	\$60.15	<a href="#">15J</a>	<a href="#">11P</a>	<a href="#">8Y</a>	<a href="#">View</a>
Skagit	<a href="#">Laborers</a>	Scaffold Erector	\$59.07	<a href="#">15J</a>	<a href="#">11P</a>	<a href="#">8Y</a>	<a href="#">View</a>
Skagit	<a href="#">Laborers</a>	Scale Person	\$59.07	<a href="#">15J</a>	<a href="#">11P</a>	<a href="#">8Y</a>	<a href="#">View</a>
Skagit	<a href="#">Laborers</a>	Sloper (Over 20")	\$60.15	<a href="#">15J</a>	<a href="#">11P</a>	<a href="#">8Y</a>	<a href="#">View</a>
Skagit	<a href="#">Laborers</a>	Sloper Sprayer	\$59.07	<a href="#">15J</a>	<a href="#">11P</a>	<a href="#">8Y</a>	<a href="#">View</a>
Skagit	<a href="#">Laborers</a>	Spreader (Concrete)	\$60.15	<a href="#">15J</a>	<a href="#">11P</a>	<a href="#">8Y</a>	<a href="#">View</a>
Skagit	<a href="#">Laborers</a>	Stake Hopper	\$59.07	<a href="#">15J</a>	<a href="#">11P</a>	<a href="#">8Y</a>	<a href="#">View</a>
Skagit	<a href="#">Laborers</a>	Stock Piler	\$59.07	<a href="#">15J</a>	<a href="#">11P</a>	<a href="#">8Y</a>	<a href="#">View</a>
Skagit	<a href="#">Laborers</a>	Swinging Stage/Boatswain Chair	\$50.07	<a href="#">15J</a>	<a href="#">11P</a>	<a href="#">8Y</a>	<a href="#">View</a>
Skagit	<a href="#">Laborers</a>	Tamper & Similar Electric, Air & Gas Operated Tools	\$60.15	<a href="#">15J</a>	<a href="#">11P</a>	<a href="#">8Y</a>	<a href="#">View</a>

Skagit	<a href="#">Laborers</a>	Tamper (Multiple & Self-propelled)	\$60.15	<a href="#">15J</a>	<a href="#">11P</a>	<a href="#">8Y</a>	<a href="#">View</a>
Skagit	<a href="#">Laborers</a>	Timber Person - Sewer (Lagger, Shorer & Cribber)	\$60.15	<a href="#">15J</a>	<a href="#">11P</a>	<a href="#">8Y</a>	<a href="#">View</a>
Skagit	<a href="#">Laborers</a>	Toolroom Person (at Jobsite)	\$59.07	<a href="#">15J</a>	<a href="#">11P</a>	<a href="#">8Y</a>	<a href="#">View</a>
Skagit	<a href="#">Laborers</a>	Topper	\$59.07	<a href="#">15J</a>	<a href="#">11P</a>	<a href="#">8Y</a>	<a href="#">View</a>
Skagit	<a href="#">Laborers</a>	Track Laborer	\$59.07	<a href="#">15J</a>	<a href="#">11P</a>	<a href="#">8Y</a>	<a href="#">View</a>
Skagit	<a href="#">Laborers</a>	Track Liner (Power)	\$60.15	<a href="#">15J</a>	<a href="#">11P</a>	<a href="#">8Y</a>	<a href="#">View</a>
Skagit	<a href="#">Laborers</a>	Traffic Control Laborer	\$53.54	<a href="#">15J</a>	<a href="#">11P</a>	<a href="#">9C</a>	<a href="#">View</a>
Skagit	<a href="#">Laborers</a>	Traffic Control Supervisor	\$56.73	<a href="#">15J</a>	<a href="#">11P</a>	<a href="#">9C</a>	<a href="#">View</a>
Skagit	<a href="#">Laborers</a>	Truck Spotter	\$59.07	<a href="#">15J</a>	<a href="#">11P</a>	<a href="#">8Y</a>	<a href="#">View</a>
Skagit	<a href="#">Laborers</a>	Tugger Operator	\$60.15	<a href="#">15J</a>	<a href="#">11P</a>	<a href="#">8Y</a>	<a href="#">View</a>
Skagit	<a href="#">Laborers</a>	Tunnel Work-Compressed Air Worker 0-30 psi	\$175.79	<a href="#">15J</a>	<a href="#">11P</a>	<a href="#">9B</a>	<a href="#">View</a>
Skagit	<a href="#">Laborers</a>	Tunnel Work-Compressed Air Worker 30.01-44.00 psi	\$180.82	<a href="#">15J</a>	<a href="#">11P</a>	<a href="#">9B</a>	<a href="#">View</a>
Skagit	<a href="#">Laborers</a>	Tunnel Work-Compressed Air Worker 44.01-54.00 psi	\$184.50	<a href="#">15J</a>	<a href="#">11P</a>	<a href="#">9B</a>	<a href="#">View</a>
Skagit	<a href="#">Laborers</a>	Tunnel Work-Compressed Air Worker 54.01-60.00 psi	\$190.20	<a href="#">15J</a>	<a href="#">11P</a>	<a href="#">9B</a>	<a href="#">View</a>
Skagit	<a href="#">Laborers</a>	Tunnel Work-Compressed Air Worker 60.01-64.00 psi	\$192.32	<a href="#">15J</a>	<a href="#">11P</a>	<a href="#">9B</a>	<a href="#">View</a>
Skagit	<a href="#">Laborers</a>	Tunnel Work-Compressed Air Worker 64.01-68.00 psi	\$197.42	<a href="#">15J</a>	<a href="#">11P</a>	<a href="#">9B</a>	<a href="#">View</a>
Skagit	<a href="#">Laborers</a>	Tunnel Work-Compressed Air Worker 68.01-70.00 psi	\$199.32	<a href="#">15J</a>	<a href="#">11P</a>	<a href="#">9B</a>	<a href="#">View</a>
Skagit	<a href="#">Laborers</a>	Tunnel Work-Compressed Air Worker 70.01-72.00 psi	\$201.32	<a href="#">15J</a>	<a href="#">11P</a>	<a href="#">9B</a>	<a href="#">View</a>
Skagit	<a href="#">Laborers</a>	Tunnel Work-Compressed Air Worker 72.01-74.00 psi	\$203.32	<a href="#">15J</a>	<a href="#">11P</a>	<a href="#">9B</a>	<a href="#">View</a>
Skagit	<a href="#">Laborers</a>	Tunnel Work-Guage and Lock Tender	\$62.59	<a href="#">15J</a>	<a href="#">11P</a>	<a href="#">8Y</a>	<a href="#">View</a>
Skagit	<a href="#">Laborers</a>	Tunnel Work-Miner	\$62.59	<a href="#">15J</a>	<a href="#">11P</a>	<a href="#">8Y</a>	<a href="#">View</a>
Skagit	<a href="#">Laborers</a>	Vibrator	\$60.15	<a href="#">15J</a>	<a href="#">11P</a>	<a href="#">8Y</a>	<a href="#">View</a>
Skagit	<a href="#">Laborers</a>	Vinyl Seamer	\$59.07	<a href="#">15J</a>	<a href="#">11P</a>	<a href="#">8Y</a>	<a href="#">View</a>
Skagit	<a href="#">Laborers</a>	Watchman	\$45.51	<a href="#">15J</a>	<a href="#">11P</a>	<a href="#">8Y</a>	<a href="#">View</a>
Skagit	<a href="#">Laborers</a>	Welder	\$60.15	<a href="#">15J</a>	<a href="#">11P</a>	<a href="#">8Y</a>	<a href="#">View</a>
Skagit	<a href="#">Laborers</a>	Well Point Laborer	\$60.15	<a href="#">15J</a>	<a href="#">11P</a>	<a href="#">8Y</a>	<a href="#">View</a>
Skagit	<a href="#">Laborers</a>	Window Washer/Cleaner	\$45.51	<a href="#">15J</a>	<a href="#">11P</a>	<a href="#">8Y</a>	<a href="#">View</a>
Skagit	<a href="#">Laborers - Underground Sewer &amp; Water</a>	General Laborer & Topman	\$59.07	<a href="#">15J</a>	<a href="#">11P</a>	<a href="#">8Y</a>	<a href="#">View</a>
Skagit	<a href="#">Laborers - Underground Sewer &amp; Water</a>	Pipe Layer	\$60.15	<a href="#">15J</a>	<a href="#">11P</a>	<a href="#">8Y</a>	<a href="#">View</a>
Skagit	<a href="#">Landscape Construction</a>	Landscape Construction/Landscaping Or Planting Laborers	\$45.51	<a href="#">15J</a>	<a href="#">11P</a>	<a href="#">8Y</a>	<a href="#">View</a>
Skagit	<a href="#">Landscape Construction</a>	Landscape Operator	\$82.25	<a href="#">15J</a>	<a href="#">11G</a>	<a href="#">8X</a>	<a href="#">View</a>
Skagit	<a href="#">Landscape Maintenance</a>	Groundskeeper	\$16.28		<a href="#">1</a>		<a href="#">View</a>
Skagit	<a href="#">Lathers</a>	Journey Level	\$75.73	<a href="#">15O</a>	<a href="#">11S</a>		<a href="#">View</a>
Skagit	<a href="#">Marble Setters</a>	Journey Level	\$69.07	<a href="#">7E</a>	<a href="#">1N</a>		<a href="#">View</a>
Skagit	<a href="#">Metal Fabrication (In Shop)</a>	Fitter	\$16.28		<a href="#">1</a>		<a href="#">View</a>
Skagit	<a href="#">Metal Fabrication (In Shop)</a>	Laborer	\$16.28		<a href="#">1</a>		<a href="#">View</a>
Skagit	<a href="#">Metal Fabrication (In Shop)</a>	Machine Operator	\$16.28		<a href="#">1</a>		<a href="#">View</a>
Skagit	<a href="#">Metal Fabrication (In Shop)</a>	Painter	\$16.28		<a href="#">1</a>		<a href="#">View</a>

Skagit	<a href="#">Metal Fabrication (In Shop)</a>	Welder	\$16.28		<u>1</u>		<a href="#">View</a>
Skagit	<a href="#">Millwright</a>	Journey Level	\$76.51	<u>15J</u>	<u>4C</u>		<a href="#">View</a>
Skagit	<a href="#">Modular Buildings</a>	Journey Level	\$16.28		<u>1</u>		<a href="#">View</a>
Skagit	<a href="#">Painters</a>	Journey Level	\$51.71	<u>6Z</u>	<u>11J</u>		<a href="#">View</a>
Skagit	<a href="#">Pile Driver</a>	Crew Tender	\$80.82	<u>15J</u>	<u>4C</u>		<a href="#">View</a>
Skagit	<a href="#">Pile Driver</a>	Journey Level	\$75.41	<u>15J</u>	<u>4C</u>		<a href="#">View</a>
Skagit	<a href="#">Plasterers</a>	Journey Level	\$70.91	<u>7Q</u>	<u>1R</u>		<a href="#">View</a>
Skagit	<a href="#">Plasterers</a>	Nozzleman	\$74.91	<u>7Q</u>	<u>1R</u>		<a href="#">View</a>
Skagit	<a href="#">Playground &amp; Park Equipment Installers</a>	Journey Level	\$16.28		<u>1</u>		<a href="#">View</a>
Skagit	<a href="#">Plumbers &amp; Pipefitters</a>	Journey Level	\$86.72	<u>5A</u>	<u>1G</u>		<a href="#">View</a>
Skagit	<a href="#">Power Equipment Operators</a>	Asphalt Plant Operators	\$83.62	<u>15J</u>	<u>11G</u>	<u>8X</u>	<a href="#">View</a>
Skagit	<a href="#">Power Equipment Operators</a>	Assistant Engineer	\$78.65	<u>15J</u>	<u>11G</u>	<u>8X</u>	<a href="#">View</a>
Skagit	<a href="#">Power Equipment Operators</a>	Barrier Machine (zipper)	\$82.88	<u>15J</u>	<u>11G</u>	<u>8X</u>	<a href="#">View</a>
Skagit	<a href="#">Power Equipment Operators</a>	Batch Plant Operator: concrete	\$82.88	<u>15J</u>	<u>11G</u>	<u>8X</u>	<a href="#">View</a>
Skagit	<a href="#">Power Equipment Operators</a>	Boat Operator	\$83.95	<u>7A</u>	<u>11H</u>	<u>8X</u>	<a href="#">View</a>
Skagit	<a href="#">Power Equipment Operators</a>	Bobcat	\$78.65	<u>15J</u>	<u>11G</u>	<u>8X</u>	<a href="#">View</a>
Skagit	<a href="#">Power Equipment Operators</a>	Brokk - Remote Demolition Equipment	\$78.65	<u>15J</u>	<u>11G</u>	<u>8X</u>	<a href="#">View</a>
Skagit	<a href="#">Power Equipment Operators</a>	Brooms	\$78.65	<u>15J</u>	<u>11G</u>	<u>8X</u>	<a href="#">View</a>
Skagit	<a href="#">Power Equipment Operators</a>	Bump Cutter	\$82.88	<u>15J</u>	<u>11G</u>	<u>8X</u>	<a href="#">View</a>
Skagit	<a href="#">Power Equipment Operators</a>	Cableways	\$83.62	<u>15J</u>	<u>11G</u>	<u>8X</u>	<a href="#">View</a>
Skagit	<a href="#">Power Equipment Operators</a>	Chipper	\$82.88	<u>15J</u>	<u>11G</u>	<u>8X</u>	<a href="#">View</a>
Skagit	<a href="#">Power Equipment Operators</a>	Compressor	\$78.65	<u>15J</u>	<u>11G</u>	<u>8X</u>	<a href="#">View</a>
Skagit	<a href="#">Power Equipment Operators</a>	Concrete Finish Machine - Laser Screed	\$78.65	<u>15J</u>	<u>11G</u>	<u>8X</u>	<a href="#">View</a>
Skagit	<a href="#">Power Equipment Operators</a>	Concrete Pump - Mounted Or Trailer High Pressure Line Pump, Pump High Pressure	\$82.25	<u>15J</u>	<u>11G</u>	<u>8X</u>	<a href="#">View</a>
Skagit	<a href="#">Power Equipment Operators</a>	Concrete Pump: Truck Mount With Boom Attachment Over 42 M	\$83.62	<u>15J</u>	<u>11G</u>	<u>8X</u>	<a href="#">View</a>
Skagit	<a href="#">Power Equipment Operators</a>	Concrete Pump: Truck Mount With Boom Attachment Up To 42m	\$82.88	<u>15J</u>	<u>11G</u>	<u>8X</u>	<a href="#">View</a>
Skagit	<a href="#">Power Equipment Operators</a>	Conveyors	\$82.25	<u>15J</u>	<u>11G</u>	<u>8X</u>	<a href="#">View</a>
Skagit	<a href="#">Power Equipment Operators</a>	Cranes Friction: 200 tons and over	\$86.48	<u>7A</u>	<u>11H</u>	<u>8X</u>	<a href="#">View</a>
Skagit	<a href="#">Power Equipment Operators</a>	Cranes, A-frame: 10 tons and under	\$78.95	<u>7A</u>	<u>11H</u>	<u>8X</u>	<a href="#">View</a>
Skagit	<a href="#">Power Equipment Operators</a>	Cranes: 100 tons through 199 tons, or 150' of boom (including jib with attachments)	\$84.77	<u>7A</u>	<u>11H</u>	<u>8X</u>	<a href="#">View</a>
Skagit	<a href="#">Power Equipment Operators</a>	Cranes: 20 tons through 44 tons with attachments	\$83.20	<u>7A</u>	<u>11H</u>	<u>8X</u>	<a href="#">View</a>
Skagit	<a href="#">Power Equipment Operators</a>	Cranes: 200 tons- 299 tons, or 250' of boom including jib with attachments	\$85.66	<u>7A</u>	<u>11H</u>	<u>8X</u>	<a href="#">View</a>
Skagit	<a href="#">Power Equipment Operators</a>	Cranes: 300 tons and over or 300' of boom including jib with attachments	\$86.48	<u>7A</u>	<u>11H</u>	<u>8X</u>	<a href="#">View</a>
Skagit	<a href="#">Power Equipment Operators</a>	Cranes: 45 tons through 99 tons, under 150' of boom(including jib with attachments)	\$83.95	<u>7A</u>	<u>11H</u>	<u>8X</u>	<a href="#">View</a>
Skagit	<a href="#">Power Equipment Operators</a>	Cranes: Friction cranes through 199 tons	\$85.66	<u>7A</u>	<u>11H</u>	<u>8X</u>	<a href="#">View</a>
Skagit	<a href="#">Power Equipment Operators</a>	Cranes: through 19 tons with attachments, a-frame over 10 tons	\$82.56	<u>7A</u>	<u>11H</u>	<u>8X</u>	<a href="#">View</a>



Skagit	<a href="#">Power Equipment Operators</a>	Crusher	\$82.88	<a href="#">15J</a>	<a href="#">11G</a>	<a href="#">8X</a>	<a href="#">View</a>
Skagit	<a href="#">Power Equipment Operators</a>	Deck Engineer/Deck Winches (power)	\$82.88	<a href="#">15J</a>	<a href="#">11G</a>	<a href="#">8X</a>	<a href="#">View</a>
Skagit	<a href="#">Power Equipment Operators</a>	Derricks, On Building Work	\$83.62	<a href="#">15J</a>	<a href="#">11G</a>	<a href="#">8X</a>	<a href="#">View</a>
Skagit	<a href="#">Power Equipment Operators</a>	Dozers D-9 & Under	\$82.25	<a href="#">15J</a>	<a href="#">11G</a>	<a href="#">8X</a>	<a href="#">View</a>
Skagit	<a href="#">Power Equipment Operators</a>	Drill Oilers: Auger Type, Truck Or Crane Mount	\$82.25	<a href="#">15J</a>	<a href="#">11G</a>	<a href="#">8X</a>	<a href="#">View</a>
Skagit	<a href="#">Power Equipment Operators</a>	Drilling Machine	\$84.46	<a href="#">15J</a>	<a href="#">11G</a>	<a href="#">8X</a>	<a href="#">View</a>
Skagit	<a href="#">Power Equipment Operators</a>	Elevator and man-lift: permanent and shaft type	\$78.65	<a href="#">15J</a>	<a href="#">11G</a>	<a href="#">8X</a>	<a href="#">View</a>
Skagit	<a href="#">Power Equipment Operators</a>	Finishing Machine, Bidwell And Gamaco & Similar Equipment	\$82.88	<a href="#">15J</a>	<a href="#">11G</a>	<a href="#">8X</a>	<a href="#">View</a>
Skagit	<a href="#">Power Equipment Operators</a>	Forklift: 3000 lbs and over with attachments	\$82.25	<a href="#">15J</a>	<a href="#">11G</a>	<a href="#">8X</a>	<a href="#">View</a>
Skagit	<a href="#">Power Equipment Operators</a>	Forklifts: under 3000 lbs. with attachments	\$78.65	<a href="#">15J</a>	<a href="#">11G</a>	<a href="#">8X</a>	<a href="#">View</a>
Skagit	<a href="#">Power Equipment Operators</a>	Grade Engineer: Using Blue Prints, Cut Sheets, Etc	\$82.88	<a href="#">15J</a>	<a href="#">11G</a>	<a href="#">8X</a>	<a href="#">View</a>
Skagit	<a href="#">Power Equipment Operators</a>	Gradechecker/Stakeman	\$78.65	<a href="#">15J</a>	<a href="#">11G</a>	<a href="#">8X</a>	<a href="#">View</a>
Skagit	<a href="#">Power Equipment Operators</a>	Guardrail Punch	\$82.88	<a href="#">15J</a>	<a href="#">11G</a>	<a href="#">8X</a>	<a href="#">View</a>
Skagit	<a href="#">Power Equipment Operators</a>	Hard Tail End Dump Articulating Off- Road Equipment 45 Yards. & Over	\$83.62	<a href="#">15J</a>	<a href="#">11G</a>	<a href="#">8X</a>	<a href="#">View</a>
Skagit	<a href="#">Power Equipment Operators</a>	Hard Tail End Dump Articulating Off-road Equipment Under 45 Yards	\$82.88	<a href="#">15J</a>	<a href="#">11G</a>	<a href="#">8X</a>	<a href="#">View</a>
Skagit	<a href="#">Power Equipment Operators</a>	Horizontal/Directional Drill Locator	\$82.25	<a href="#">15J</a>	<a href="#">11G</a>	<a href="#">8X</a>	<a href="#">View</a>
Skagit	<a href="#">Power Equipment Operators</a>	Horizontal/Directional Drill Operator	\$82.88	<a href="#">15J</a>	<a href="#">11G</a>	<a href="#">8X</a>	<a href="#">View</a>
Skagit	<a href="#">Power Equipment Operators</a>	Hydralifts/Boom Trucks Over 10 Tons	\$82.56	<a href="#">7A</a>	<a href="#">11H</a>	<a href="#">8X</a>	<a href="#">View</a>
Skagit	<a href="#">Power Equipment Operators</a>	Hydralifts/boom trucks: 10 tons and under	\$78.95	<a href="#">7A</a>	<a href="#">11H</a>	<a href="#">8X</a>	<a href="#">View</a>
Skagit	<a href="#">Power Equipment Operators</a>	Leverman	\$85.33	<a href="#">15J</a>	<a href="#">11G</a>	<a href="#">8X</a>	<a href="#">View</a>
Skagit	<a href="#">Power Equipment Operators</a>	Loader, Overhead, 6 Yards. But Not Including 8 Yards	\$83.62	<a href="#">15J</a>	<a href="#">11G</a>	<a href="#">8X</a>	<a href="#">View</a>
Skagit	<a href="#">Power Equipment Operators</a>	Loaders, Overhead Under 6 Yards	\$82.88	<a href="#">15J</a>	<a href="#">11G</a>	<a href="#">8X</a>	<a href="#">View</a>
Skagit	<a href="#">Power Equipment Operators</a>	Loaders, Plant Feed	\$82.88	<a href="#">15J</a>	<a href="#">11G</a>	<a href="#">8X</a>	<a href="#">View</a>
Skagit	<a href="#">Power Equipment Operators</a>	Loaders: Elevating Type Belt	\$82.25	<a href="#">15J</a>	<a href="#">11G</a>	<a href="#">8X</a>	<a href="#">View</a>
Skagit	<a href="#">Power Equipment Operators</a>	Locomotives, All	\$82.88	<a href="#">15J</a>	<a href="#">11G</a>	<a href="#">8X</a>	<a href="#">View</a>
Skagit	<a href="#">Power Equipment Operators</a>	Material Transfer Device	\$82.88	<a href="#">15J</a>	<a href="#">11G</a>	<a href="#">8X</a>	<a href="#">View</a>
Skagit	<a href="#">Power Equipment Operators</a>	Mechanics: All (Leadmen - \$0.50 per hour over mechanic)	\$84.46	<a href="#">15J</a>	<a href="#">11G</a>	<a href="#">8X</a>	<a href="#">View</a>
Skagit	<a href="#">Power Equipment Operators</a>	Motor Patrol Graders	\$83.62	<a href="#">15J</a>	<a href="#">11G</a>	<a href="#">8X</a>	<a href="#">View</a>
Skagit	<a href="#">Power Equipment Operators</a>	Mucking Machine, Mole, Tunnel Drill, Boring, Road Header And/or Shield	\$83.62	<a href="#">15J</a>	<a href="#">11G</a>	<a href="#">8X</a>	<a href="#">View</a>
Skagit	<a href="#">Power Equipment Operators</a>	Oil Distributors, Blower Distribution & Mulch Seeding Operator	\$78.65	<a href="#">15J</a>	<a href="#">11G</a>	<a href="#">8X</a>	<a href="#">View</a>
Skagit	<a href="#">Power Equipment Operators</a>	Outside Hoists (Elevators and Manlifts), Air Tuggers, Strato	\$82.25	<a href="#">15J</a>	<a href="#">11G</a>	<a href="#">8X</a>	<a href="#">View</a>
Skagit	<a href="#">Power Equipment Operators</a>	Overhead, bridge type Crane: 20 tons through 44 tons	\$83.20	<a href="#">7A</a>	<a href="#">11H</a>	<a href="#">8X</a>	<a href="#">View</a>
Skagit	<a href="#">Power Equipment Operators</a>	Overhead, bridge type: 100 tons and over	\$84.77	<a href="#">7A</a>	<a href="#">11H</a>	<a href="#">8X</a>	<a href="#">View</a>

Skagit	<a href="#">Power Equipment Operators</a>	Overhead, bridge type: 45 tons through 99 tons	\$83.95	<a href="#">7A</a>	<a href="#">11H</a>	<a href="#">8X</a>	<a href="#">View</a>
Skagit	<a href="#">Power Equipment Operators</a>	Pavement Breaker	\$78.65	<a href="#">15J</a>	<a href="#">11G</a>	<a href="#">8X</a>	<a href="#">View</a>
Skagit	<a href="#">Power Equipment Operators</a>	Pile Driver (other Than Crane Mount)	\$82.88	<a href="#">15J</a>	<a href="#">11G</a>	<a href="#">8X</a>	<a href="#">View</a>
Skagit	<a href="#">Power Equipment Operators</a>	Plant Oiler - Asphalt, Crusher	\$82.25	<a href="#">15J</a>	<a href="#">11G</a>	<a href="#">8X</a>	<a href="#">View</a>
Skagit	<a href="#">Power Equipment Operators</a>	Posthole Digger, Mechanical	\$78.65	<a href="#">15J</a>	<a href="#">11G</a>	<a href="#">8X</a>	<a href="#">View</a>
Skagit	<a href="#">Power Equipment Operators</a>	Power Plant	\$78.65	<a href="#">15J</a>	<a href="#">11G</a>	<a href="#">8X</a>	<a href="#">View</a>
Skagit	<a href="#">Power Equipment Operators</a>	Pumps - Water	\$78.65	<a href="#">15J</a>	<a href="#">11G</a>	<a href="#">8X</a>	<a href="#">View</a>
Skagit	<a href="#">Power Equipment Operators</a>	Quad 9, Hd 41, D10 And Over	\$83.62	<a href="#">15J</a>	<a href="#">11G</a>	<a href="#">8X</a>	<a href="#">View</a>
Skagit	<a href="#">Power Equipment Operators</a>	Quick Tower: no cab, under 100 feet in height base to boom	\$82.88	<a href="#">15J</a>	<a href="#">11G</a>	<a href="#">8X</a>	<a href="#">View</a>
Skagit	<a href="#">Power Equipment Operators</a>	Remote Control Operator On Rubber Tired Earth Moving Equipment	\$83.62	<a href="#">15J</a>	<a href="#">11G</a>	<a href="#">8X</a>	<a href="#">View</a>
Skagit	<a href="#">Power Equipment Operators</a>	Rigger and Bellman	\$78.95	<a href="#">7A</a>	<a href="#">11H</a>	<a href="#">8X</a>	<a href="#">View</a>
Skagit	<a href="#">Power Equipment Operators</a>	Rigger/Signal Person, Bellman(Certified)	\$82.56	<a href="#">7A</a>	<a href="#">11H</a>	<a href="#">8X</a>	<a href="#">View</a>
Skagit	<a href="#">Power Equipment Operators</a>	Rollagon	\$83.62	<a href="#">15J</a>	<a href="#">11G</a>	<a href="#">8X</a>	<a href="#">View</a>
Skagit	<a href="#">Power Equipment Operators</a>	Roller, Other Than Plant Mix	\$78.65	<a href="#">15J</a>	<a href="#">11G</a>	<a href="#">8X</a>	<a href="#">View</a>
Skagit	<a href="#">Power Equipment Operators</a>	Roller, Plant Mix Or Multi-lift Materials	\$82.25	<a href="#">15J</a>	<a href="#">11G</a>	<a href="#">8X</a>	<a href="#">View</a>
Skagit	<a href="#">Power Equipment Operators</a>	Roto-mill, Roto-grinder	\$82.88	<a href="#">15J</a>	<a href="#">11G</a>	<a href="#">8X</a>	<a href="#">View</a>
Skagit	<a href="#">Power Equipment Operators</a>	Saws - Concrete	\$82.25	<a href="#">15J</a>	<a href="#">11G</a>	<a href="#">8X</a>	<a href="#">View</a>
Skagit	<a href="#">Power Equipment Operators</a>	Scraper, Self Propelled Under 45 Yards	\$82.88	<a href="#">15J</a>	<a href="#">11G</a>	<a href="#">8X</a>	<a href="#">View</a>
Skagit	<a href="#">Power Equipment Operators</a>	Scrapers - Concrete & Carry All	\$82.25	<a href="#">15J</a>	<a href="#">11G</a>	<a href="#">8X</a>	<a href="#">View</a>
Skagit	<a href="#">Power Equipment Operators</a>	Scrapers, Self-propelled: 45 Yards And Over	\$83.62	<a href="#">15J</a>	<a href="#">11G</a>	<a href="#">8X</a>	<a href="#">View</a>
Skagit	<a href="#">Power Equipment Operators</a>	Service Engineers: Equipment	\$82.25	<a href="#">15J</a>	<a href="#">11G</a>	<a href="#">8X</a>	<a href="#">View</a>
Skagit	<a href="#">Power Equipment Operators</a>	Shotcrete/Gunite Equipment	\$78.65	<a href="#">15J</a>	<a href="#">11G</a>	<a href="#">8X</a>	<a href="#">View</a>
Skagit	<a href="#">Power Equipment Operators</a>	Shovel, Excavator, Backhoe, Tractors Under 15 Metric Tons	\$82.25	<a href="#">15J</a>	<a href="#">11G</a>	<a href="#">8X</a>	<a href="#">View</a>
Skagit	<a href="#">Power Equipment Operators</a>	Shovel, Excavator, Backhoe: Over 30 Metric Tons To 50 Metric Tons	\$83.62	<a href="#">15J</a>	<a href="#">11G</a>	<a href="#">8X</a>	<a href="#">View</a>
Skagit	<a href="#">Power Equipment Operators</a>	Shovel, Excavator, Backhoes, Tractors: 15 To 30 Metric Tons	\$82.88	<a href="#">15J</a>	<a href="#">11G</a>	<a href="#">8X</a>	<a href="#">View</a>
Skagit	<a href="#">Power Equipment Operators</a>	Shovel, Excavator, Backhoes: Over 50 Metric Tons To 90 Metric Tons	\$84.46	<a href="#">15J</a>	<a href="#">11G</a>	<a href="#">8X</a>	<a href="#">View</a>
Skagit	<a href="#">Power Equipment Operators</a>	Shovel, Excavator, Backhoes: Over 90 Metric Tons	\$85.33	<a href="#">15J</a>	<a href="#">11G</a>	<a href="#">8X</a>	<a href="#">View</a>
Skagit	<a href="#">Power Equipment Operators</a>	Slipform Pavers	\$83.62	<a href="#">15J</a>	<a href="#">11G</a>	<a href="#">8X</a>	<a href="#">View</a>
Skagit	<a href="#">Power Equipment Operators</a>	Spreader, Toppers & Screedman	\$83.62	<a href="#">15J</a>	<a href="#">11G</a>	<a href="#">8X</a>	<a href="#">View</a>
Skagit	<a href="#">Power Equipment Operators</a>	Subgrader Trimmer	\$82.88	<a href="#">15J</a>	<a href="#">11G</a>	<a href="#">8X</a>	<a href="#">View</a>
Skagit	<a href="#">Power Equipment Operators</a>	Tower Bucket Elevators	\$82.25	<a href="#">15J</a>	<a href="#">11G</a>	<a href="#">8X</a>	<a href="#">View</a>
Skagit	<a href="#">Power Equipment Operators</a>	Tower Crane: over 175' through 250' in height, base to boom	\$85.66	<a href="#">7A</a>	<a href="#">11H</a>	<a href="#">8X</a>	<a href="#">View</a>
Skagit	<a href="#">Power Equipment Operators</a>	Tower crane: up to 175' in height base to boom	\$84.77	<a href="#">7A</a>	<a href="#">11H</a>	<a href="#">8X</a>	<a href="#">View</a>
Skagit	<a href="#">Power Equipment Operators</a>	Tower Cranes: over 250' in height from base to boom	\$86.48	<a href="#">7A</a>	<a href="#">11H</a>	<a href="#">8X</a>	<a href="#">View</a>
Skagit	<a href="#">Power Equipment Operators</a>	Transporters, All Track Or Truck Type	\$83.62	<a href="#">15J</a>	<a href="#">11G</a>	<a href="#">8X</a>	<a href="#">View</a>
Skagit	<a href="#">Power Equipment Operators</a>	Trenching Machines	\$82.25	<a href="#">15J</a>	<a href="#">11G</a>	<a href="#">8X</a>	<a href="#">View</a>

Skagit	<a href="#">Power Equipment Operators</a>	Truck Crane Oiler/Driver: 100 tons and over	\$83.20	<a href="#">7A</a>	<a href="#">11H</a>	<a href="#">8X</a>	<a href="#">View</a>
Skagit	<a href="#">Power Equipment Operators</a>	Truck crane oiler/driver: under 100 tons	\$82.56	<a href="#">7A</a>	<a href="#">11H</a>	<a href="#">8X</a>	<a href="#">View</a>
Skagit	<a href="#">Power Equipment Operators</a>	Truck Mount Portable Conveyor	\$82.88	<a href="#">15J</a>	<a href="#">11G</a>	<a href="#">8X</a>	<a href="#">View</a>
Skagit	<a href="#">Power Equipment Operators</a>	Vac Truck (Vactor Guzzler, Hydro Excavator)	\$82.88	<a href="#">15J</a>	<a href="#">11G</a>	<a href="#">8X</a>	<a href="#">View</a>
Skagit	<a href="#">Power Equipment Operators</a>	Welder	\$83.62	<a href="#">15J</a>	<a href="#">11G</a>	<a href="#">8X</a>	<a href="#">View</a>
Skagit	<a href="#">Power Equipment Operators</a>	Wheel Tractors, Farmall Type	\$78.65	<a href="#">15J</a>	<a href="#">11G</a>	<a href="#">8X</a>	<a href="#">View</a>
Skagit	<a href="#">Power Equipment Operators</a>	Yo Yo Pay Dozer	\$82.88	<a href="#">15J</a>	<a href="#">11G</a>	<a href="#">8X</a>	<a href="#">View</a>
Skagit	<a href="#">Power Equipment Operators-Underground Sewer &amp; Water</a>	Asphalt Plant Operators	\$83.62	<a href="#">15J</a>	<a href="#">11G</a>	<a href="#">8X</a>	<a href="#">View</a>
Skagit	<a href="#">Power Equipment Operators-Underground Sewer &amp; Water</a>	Assistant Engineer	\$78.65	<a href="#">15J</a>	<a href="#">11G</a>	<a href="#">8X</a>	<a href="#">View</a>
Skagit	<a href="#">Power Equipment Operators-Underground Sewer &amp; Water</a>	Barrier Machine (zipper)	\$82.88	<a href="#">15J</a>	<a href="#">11G</a>	<a href="#">8X</a>	<a href="#">View</a>
Skagit	<a href="#">Power Equipment Operators-Underground Sewer &amp; Water</a>	Batch Plant Operator, Concrete	\$82.88	<a href="#">15J</a>	<a href="#">11G</a>	<a href="#">8X</a>	<a href="#">View</a>
Skagit	<a href="#">Power Equipment Operators-Underground Sewer &amp; Water</a>	Boat Operator	\$83.95	<a href="#">7A</a>	<a href="#">11H</a>	<a href="#">8X</a>	<a href="#">View</a>
Skagit	<a href="#">Power Equipment Operators-Underground Sewer &amp; Water</a>	Bobcat	\$78.65	<a href="#">15J</a>	<a href="#">11G</a>	<a href="#">8X</a>	<a href="#">View</a>
Skagit	<a href="#">Power Equipment Operators-Underground Sewer &amp; Water</a>	Brokk - Remote Demolition Equipment	\$78.65	<a href="#">15J</a>	<a href="#">11G</a>	<a href="#">8X</a>	<a href="#">View</a>
Skagit	<a href="#">Power Equipment Operators-Underground Sewer &amp; Water</a>	Brooms	\$78.65	<a href="#">15J</a>	<a href="#">11G</a>	<a href="#">8X</a>	<a href="#">View</a>
Skagit	<a href="#">Power Equipment Operators-Underground Sewer &amp; Water</a>	Bump Cutter	\$82.88	<a href="#">15J</a>	<a href="#">11G</a>	<a href="#">8X</a>	<a href="#">View</a>
Skagit	<a href="#">Power Equipment Operators-Underground Sewer &amp; Water</a>	Cableways	\$83.62	<a href="#">15J</a>	<a href="#">11G</a>	<a href="#">8X</a>	<a href="#">View</a>
Skagit	<a href="#">Power Equipment Operators-Underground Sewer &amp; Water</a>	Chipper	\$82.88	<a href="#">15J</a>	<a href="#">11G</a>	<a href="#">8X</a>	<a href="#">View</a>
Skagit	<a href="#">Power Equipment Operators-Underground Sewer &amp; Water</a>	Compressor	\$78.65	<a href="#">15J</a>	<a href="#">11G</a>	<a href="#">8X</a>	<a href="#">View</a>
Skagit	<a href="#">Power Equipment Operators-Underground Sewer &amp; Water</a>	Concrete Finish Machine - Laser Screed	\$78.65	<a href="#">15J</a>	<a href="#">11G</a>	<a href="#">8X</a>	<a href="#">View</a>
Skagit	<a href="#">Power Equipment Operators-Underground Sewer &amp; Water</a>	Concrete Pump - Mounted Or Trailer High Pressure Line Pump, Pump High Pressure	\$82.25	<a href="#">15J</a>	<a href="#">11G</a>	<a href="#">8X</a>	<a href="#">View</a>
Skagit	<a href="#">Power Equipment Operators-Underground Sewer &amp; Water</a>	Concrete Pump: Truck Mount With Boom Attachment Over 42 M	\$83.62	<a href="#">15J</a>	<a href="#">11G</a>	<a href="#">8X</a>	<a href="#">View</a>
Skagit	<a href="#">Power Equipment Operators-Underground Sewer &amp; Water</a>	Concrete Pump: Truck Mount With Boom Attachment Up To 42m	\$82.88	<a href="#">15J</a>	<a href="#">11G</a>	<a href="#">8X</a>	<a href="#">View</a>
Skagit	<a href="#">Power Equipment Operators-Underground Sewer &amp; Water</a>	Conveyors	\$82.25	<a href="#">15J</a>	<a href="#">11G</a>	<a href="#">8X</a>	<a href="#">View</a>
Skagit	<a href="#">Power Equipment Operators-Underground Sewer &amp; Water</a>	Cranes Friction: 200 tons and over	\$86.48	<a href="#">7A</a>	<a href="#">11H</a>	<a href="#">8X</a>	<a href="#">View</a>
Skagit	<a href="#">Power Equipment Operators-Underground Sewer &amp; Water</a>	Cranes, A-frame: 10 tons and under	\$78.95	<a href="#">7A</a>	<a href="#">11H</a>	<a href="#">8X</a>	<a href="#">View</a>
Skagit	<a href="#">Power Equipment Operators-Underground Sewer &amp; Water</a>	Cranes: 100 tons through 199 tons, or 150' of boom (including jib with attachments)	\$84.77	<a href="#">7A</a>	<a href="#">11H</a>	<a href="#">8X</a>	<a href="#">View</a>
Skagit	<a href="#">Power Equipment Operators-Underground Sewer &amp; Water</a>	Cranes: 20 tons through 44 tons with attachments	\$83.20	<a href="#">7A</a>	<a href="#">11H</a>	<a href="#">8X</a>	<a href="#">View</a>
Skagit	<a href="#">Power Equipment Operators-Underground Sewer &amp; Water</a>	Cranes: 200 tons- 299 tons, or 250' of boom including jib with	\$85.66	<a href="#">7A</a>	<a href="#">11H</a>	<a href="#">8X</a>	<a href="#">View</a>



		attachments					
Skagit	<a href="#">Power Equipment Operators-Underground Sewer &amp; Water</a>	Cranes: 300 tons and over or 300' of boom including jib with attachments	\$86.48	<a href="#">7A</a>	<a href="#">11H</a>	<a href="#">8X</a>	<a href="#">View</a>
Skagit	<a href="#">Power Equipment Operators-Underground Sewer &amp; Water</a>	Cranes: 45 tons through 99 tons, under 150' of boom(including jib with attachments)	\$83.95	<a href="#">7A</a>	<a href="#">11H</a>	<a href="#">8X</a>	<a href="#">View</a>
Skagit	<a href="#">Power Equipment Operators-Underground Sewer &amp; Water</a>	Cranes: Friction cranes through 199 tons	\$85.66	<a href="#">7A</a>	<a href="#">11H</a>	<a href="#">8X</a>	<a href="#">View</a>
Skagit	<a href="#">Power Equipment Operators-Underground Sewer &amp; Water</a>	Cranes: through 19 tons with attachments, a-frame over 10 tons	\$82.56	<a href="#">7A</a>	<a href="#">11H</a>	<a href="#">8X</a>	<a href="#">View</a>
Skagit	<a href="#">Power Equipment Operators-Underground Sewer &amp; Water</a>	Crusher	\$82.88	<a href="#">15J</a>	<a href="#">11G</a>	<a href="#">8X</a>	<a href="#">View</a>
Skagit	<a href="#">Power Equipment Operators-Underground Sewer &amp; Water</a>	Deck Engineer/Deck Winches (power)	\$82.88	<a href="#">15J</a>	<a href="#">11G</a>	<a href="#">8X</a>	<a href="#">View</a>
Skagit	<a href="#">Power Equipment Operators-Underground Sewer &amp; Water</a>	Derricks, On Building Work	\$83.62	<a href="#">15J</a>	<a href="#">11G</a>	<a href="#">8X</a>	<a href="#">View</a>
Skagit	<a href="#">Power Equipment Operators-Underground Sewer &amp; Water</a>	Dozers D-9 & Under	\$82.25	<a href="#">15J</a>	<a href="#">11G</a>	<a href="#">8X</a>	<a href="#">View</a>
Skagit	<a href="#">Power Equipment Operators-Underground Sewer &amp; Water</a>	Drill Oilers: Auger Type, Truck Or Crane Mount	\$82.25	<a href="#">15J</a>	<a href="#">11G</a>	<a href="#">8X</a>	<a href="#">View</a>
Skagit	<a href="#">Power Equipment Operators-Underground Sewer &amp; Water</a>	Drilling Machine	\$84.46	<a href="#">15J</a>	<a href="#">11G</a>	<a href="#">8X</a>	<a href="#">View</a>
Skagit	<a href="#">Power Equipment Operators-Underground Sewer &amp; Water</a>	Elevator and man-lift: permanent and shaft type	\$78.65	<a href="#">15J</a>	<a href="#">11G</a>	<a href="#">8X</a>	<a href="#">View</a>
Skagit	<a href="#">Power Equipment Operators-Underground Sewer &amp; Water</a>	Finishing Machine, Bidwell And Gamaco & Similar Equipment	\$82.88	<a href="#">15J</a>	<a href="#">11G</a>	<a href="#">8X</a>	<a href="#">View</a>
Skagit	<a href="#">Power Equipment Operators-Underground Sewer &amp; Water</a>	Forklift: 3000 lbs and over with attachments	\$82.25	<a href="#">15J</a>	<a href="#">11G</a>	<a href="#">8X</a>	<a href="#">View</a>
Skagit	<a href="#">Power Equipment Operators-Underground Sewer &amp; Water</a>	Forklifts: under 3000 lbs. with attachments	\$78.65	<a href="#">15J</a>	<a href="#">11G</a>	<a href="#">8X</a>	<a href="#">View</a>
Skagit	<a href="#">Power Equipment Operators-Underground Sewer &amp; Water</a>	Grade Engineer: Using Blue Prints, Cut Sheets, Etc	\$82.88	<a href="#">15J</a>	<a href="#">11G</a>	<a href="#">8X</a>	<a href="#">View</a>
Skagit	<a href="#">Power Equipment Operators-Underground Sewer &amp; Water</a>	Gradechecker/Stakeman	\$78.65	<a href="#">15J</a>	<a href="#">11G</a>	<a href="#">8X</a>	<a href="#">View</a>
Skagit	<a href="#">Power Equipment Operators-Underground Sewer &amp; Water</a>	Guardrail Punch	\$82.88	<a href="#">15J</a>	<a href="#">11G</a>	<a href="#">8X</a>	<a href="#">View</a>
Skagit	<a href="#">Power Equipment Operators-Underground Sewer &amp; Water</a>	Hard Tail End Dump Articulating Off- Road Equipment 45 Yards. & Over	\$83.62	<a href="#">15J</a>	<a href="#">11G</a>	<a href="#">8X</a>	<a href="#">View</a>
Skagit	<a href="#">Power Equipment Operators-Underground Sewer &amp; Water</a>	Hard Tail End Dump Articulating Off-road Equipment Under 45 Yards	\$82.88	<a href="#">15J</a>	<a href="#">11G</a>	<a href="#">8X</a>	<a href="#">View</a>
Skagit	<a href="#">Power Equipment Operators-Underground Sewer &amp; Water</a>	Horizontal/Directional Drill Locator	\$82.25	<a href="#">15J</a>	<a href="#">11G</a>	<a href="#">8X</a>	<a href="#">View</a>
Skagit	<a href="#">Power Equipment Operators-Underground Sewer &amp; Water</a>	Horizontal/Directional Drill Operator	\$82.88	<a href="#">15J</a>	<a href="#">11G</a>	<a href="#">8X</a>	<a href="#">View</a>
Skagit	<a href="#">Power Equipment Operators-Underground Sewer &amp; Water</a>	Hydralifts/boom trucks: 10 tons and under	\$78.95	<a href="#">7A</a>	<a href="#">11H</a>	<a href="#">8X</a>	<a href="#">View</a>
Skagit	<a href="#">Power Equipment Operators-Underground Sewer &amp; Water</a>	Hydralifts/boom trucks: over 10 tons	\$82.56	<a href="#">7A</a>	<a href="#">11H</a>	<a href="#">8X</a>	<a href="#">View</a>
Skagit	<a href="#">Power Equipment Operators-Underground Sewer &amp; Water</a>	Leverman	\$85.33	<a href="#">15J</a>	<a href="#">11G</a>	<a href="#">8X</a>	<a href="#">View</a>
Skagit	<a href="#">Power Equipment Operators-Underground Sewer &amp; Water</a>	Loader, Overhead, 6 Yards. But Not Including 8 Yards	\$83.62	<a href="#">15J</a>	<a href="#">11G</a>	<a href="#">8X</a>	<a href="#">View</a>
Skagit	<a href="#">Power Equipment Operators-Underground Sewer &amp; Water</a>	Loaders, Overhead Under 6 Yards	\$82.88	<a href="#">15J</a>	<a href="#">11G</a>	<a href="#">8X</a>	<a href="#">View</a>

Skagit	<a href="#">Power Equipment Operators-Underground Sewer &amp; Water</a>	Loaders, Plant Feed	\$82.88	<a href="#">15J</a>	<a href="#">11G</a>	<a href="#">8X</a>	<a href="#">View</a>
Skagit	<a href="#">Power Equipment Operators-Underground Sewer &amp; Water</a>	Loaders: Elevating Type Belt	\$82.25	<a href="#">15J</a>	<a href="#">11G</a>	<a href="#">8X</a>	<a href="#">View</a>
Skagit	<a href="#">Power Equipment Operators-Underground Sewer &amp; Water</a>	Locomotives, All	\$82.88	<a href="#">15J</a>	<a href="#">11G</a>	<a href="#">8X</a>	<a href="#">View</a>
Skagit	<a href="#">Power Equipment Operators-Underground Sewer &amp; Water</a>	Material Transfer Device	\$82.88	<a href="#">15J</a>	<a href="#">11G</a>	<a href="#">8X</a>	<a href="#">View</a>
Skagit	<a href="#">Power Equipment Operators-Underground Sewer &amp; Water</a>	Mechanics: All (Leadmen - \$0.50 per hour over mechanic)	\$84.46	<a href="#">15J</a>	<a href="#">11G</a>	<a href="#">8X</a>	<a href="#">View</a>
Skagit	<a href="#">Power Equipment Operators-Underground Sewer &amp; Water</a>	Motor Patrol Graders	\$83.62	<a href="#">15J</a>	<a href="#">11G</a>	<a href="#">8X</a>	<a href="#">View</a>
Skagit	<a href="#">Power Equipment Operators-Underground Sewer &amp; Water</a>	Mucking Machine, Mole, Tunnel Drill, Boring, Road Header And/or Shield	\$83.62	<a href="#">15J</a>	<a href="#">11G</a>	<a href="#">8X</a>	<a href="#">View</a>
Skagit	<a href="#">Power Equipment Operators-Underground Sewer &amp; Water</a>	Oil Distributors, Blower Distribution & Mulch Seeding Operator	\$78.65	<a href="#">15J</a>	<a href="#">11G</a>	<a href="#">8X</a>	<a href="#">View</a>
Skagit	<a href="#">Power Equipment Operators-Underground Sewer &amp; Water</a>	Outside Hoists (Elevators and Manlifts), Air Tuggers, Strato	\$82.25	<a href="#">15J</a>	<a href="#">11G</a>	<a href="#">8X</a>	<a href="#">View</a>
Skagit	<a href="#">Power Equipment Operators-Underground Sewer &amp; Water</a>	Overhead, bridge type Crane: 20 tons through 44 tons	\$83.20	<a href="#">7A</a>	<a href="#">11H</a>	<a href="#">8X</a>	<a href="#">View</a>
Skagit	<a href="#">Power Equipment Operators-Underground Sewer &amp; Water</a>	Overhead, bridge type: 100 tons and over	\$84.77	<a href="#">7A</a>	<a href="#">11H</a>	<a href="#">8X</a>	<a href="#">View</a>
Skagit	<a href="#">Power Equipment Operators-Underground Sewer &amp; Water</a>	Overhead, bridge type: 45 tons through 99 tons	\$83.95	<a href="#">7A</a>	<a href="#">11H</a>	<a href="#">8X</a>	<a href="#">View</a>
Skagit	<a href="#">Power Equipment Operators-Underground Sewer &amp; Water</a>	Pavement Breaker	\$78.65	<a href="#">15J</a>	<a href="#">11G</a>	<a href="#">8X</a>	<a href="#">View</a>
Skagit	<a href="#">Power Equipment Operators-Underground Sewer &amp; Water</a>	Pile Driver (other Than Crane Mount)	\$82.88	<a href="#">15J</a>	<a href="#">11G</a>	<a href="#">8X</a>	<a href="#">View</a>
Skagit	<a href="#">Power Equipment Operators-Underground Sewer &amp; Water</a>	Plant Oiler - Asphalt, Crusher	\$82.25	<a href="#">15J</a>	<a href="#">11G</a>	<a href="#">8X</a>	<a href="#">View</a>
Skagit	<a href="#">Power Equipment Operators-Underground Sewer &amp; Water</a>	Posthole Digger, Mechanical	\$78.65	<a href="#">15J</a>	<a href="#">11G</a>	<a href="#">8X</a>	<a href="#">View</a>
Skagit	<a href="#">Power Equipment Operators-Underground Sewer &amp; Water</a>	Power Plant	\$78.65	<a href="#">15J</a>	<a href="#">11G</a>	<a href="#">8X</a>	<a href="#">View</a>
Skagit	<a href="#">Power Equipment Operators-Underground Sewer &amp; Water</a>	Pumps - Water	\$78.65	<a href="#">15J</a>	<a href="#">11G</a>	<a href="#">8X</a>	<a href="#">View</a>
Skagit	<a href="#">Power Equipment Operators-Underground Sewer &amp; Water</a>	Quad 9, Hd 41, D10 And Over	\$83.62	<a href="#">15J</a>	<a href="#">11G</a>	<a href="#">8X</a>	<a href="#">View</a>
Skagit	<a href="#">Power Equipment Operators-Underground Sewer &amp; Water</a>	Quick Tower: no cab, under 100 feet in height base to boom	\$82.88	<a href="#">15J</a>	<a href="#">11G</a>	<a href="#">8X</a>	<a href="#">View</a>
Skagit	<a href="#">Power Equipment Operators-Underground Sewer &amp; Water</a>	Remote Control Operator On Rubber Tired Earth Moving Equipment	\$83.62	<a href="#">15J</a>	<a href="#">11G</a>	<a href="#">8X</a>	<a href="#">View</a>
Skagit	<a href="#">Power Equipment Operators-Underground Sewer &amp; Water</a>	Rigger and Bellman	\$78.95	<a href="#">7A</a>	<a href="#">11H</a>	<a href="#">8X</a>	<a href="#">View</a>
Skagit	<a href="#">Power Equipment Operators-Underground Sewer &amp; Water</a>	Rigger/Signal Person, Bellman(Certified)	\$82.56	<a href="#">7A</a>	<a href="#">11H</a>	<a href="#">8X</a>	<a href="#">View</a>
Skagit	<a href="#">Power Equipment Operators-Underground Sewer &amp; Water</a>	Rollagon	\$83.62	<a href="#">15J</a>	<a href="#">11G</a>	<a href="#">8X</a>	<a href="#">View</a>
Skagit	<a href="#">Power Equipment Operators-Underground Sewer &amp; Water</a>	Roller, Other Than Plant Mix	\$78.65	<a href="#">15J</a>	<a href="#">11G</a>	<a href="#">8X</a>	<a href="#">View</a>
Skagit	<a href="#">Power Equipment Operators-Underground Sewer &amp; Water</a>	Roller, Plant Mix Or Multi-lift Materials	\$82.25	<a href="#">15J</a>	<a href="#">11G</a>	<a href="#">8X</a>	<a href="#">View</a>
Skagit	<a href="#">Power Equipment Operators-Underground Sewer &amp; Water</a>	Roto-mill, Roto-grinder	\$82.88	<a href="#">15J</a>	<a href="#">11G</a>	<a href="#">8X</a>	<a href="#">View</a>

Skagit	<a href="#">Power Equipment Operators-Underground Sewer &amp; Water</a>	Saws - Concrete	\$82.25	<a href="#">15J</a>	<a href="#">11G</a>	<a href="#">8X</a>	<a href="#">View</a>
Skagit	<a href="#">Power Equipment Operators-Underground Sewer &amp; Water</a>	Scraper, Self Propelled Under 45 Yards	\$82.88	<a href="#">15J</a>	<a href="#">11G</a>	<a href="#">8X</a>	<a href="#">View</a>
Skagit	<a href="#">Power Equipment Operators-Underground Sewer &amp; Water</a>	Scrapers - Concrete & Carry All	\$82.25	<a href="#">15J</a>	<a href="#">11G</a>	<a href="#">8X</a>	<a href="#">View</a>
Skagit	<a href="#">Power Equipment Operators-Underground Sewer &amp; Water</a>	Scrapers, Self-propelled: 45 Yards And Over	\$83.62	<a href="#">15J</a>	<a href="#">11G</a>	<a href="#">8X</a>	<a href="#">View</a>
Skagit	<a href="#">Power Equipment Operators-Underground Sewer &amp; Water</a>	Shotcrete/Gunite Equipment	\$78.65	<a href="#">15J</a>	<a href="#">11G</a>	<a href="#">8X</a>	<a href="#">View</a>
Skagit	<a href="#">Power Equipment Operators-Underground Sewer &amp; Water</a>	Shovel, Excavator, Backhoe, Tractors Under 15 Metric Tons	\$82.25	<a href="#">15J</a>	<a href="#">11G</a>	<a href="#">8X</a>	<a href="#">View</a>
Skagit	<a href="#">Power Equipment Operators-Underground Sewer &amp; Water</a>	Shovel, Excavator, Backhoe: Over 30 Metric Tons To 50 Metric Tons	\$83.62	<a href="#">15J</a>	<a href="#">11G</a>	<a href="#">8X</a>	<a href="#">View</a>
Skagit	<a href="#">Power Equipment Operators-Underground Sewer &amp; Water</a>	Shovel, Excavator, Backhoes, Tractors: 15 To 30 Metric Tons	\$82.88	<a href="#">15J</a>	<a href="#">11G</a>	<a href="#">8X</a>	<a href="#">View</a>
Skagit	<a href="#">Power Equipment Operators-Underground Sewer &amp; Water</a>	Shovel, Excavator, Backhoes: Over 50 Metric Tons To 90 Metric Tons	\$84.46	<a href="#">15J</a>	<a href="#">11G</a>	<a href="#">8X</a>	<a href="#">View</a>
Skagit	<a href="#">Power Equipment Operators-Underground Sewer &amp; Water</a>	Shovel, Excavator, Backhoes: Over 90 Metric Tons	\$85.33	<a href="#">15J</a>	<a href="#">11G</a>	<a href="#">8X</a>	<a href="#">View</a>
Skagit	<a href="#">Power Equipment Operators-Underground Sewer &amp; Water</a>	Slipform Pavers	\$83.62	<a href="#">15J</a>	<a href="#">11G</a>	<a href="#">8X</a>	<a href="#">View</a>
Skagit	<a href="#">Power Equipment Operators-Underground Sewer &amp; Water</a>	Spreader, Topsider & Screedman	\$83.62	<a href="#">15J</a>	<a href="#">11G</a>	<a href="#">8X</a>	<a href="#">View</a>
Skagit	<a href="#">Power Equipment Operators-Underground Sewer &amp; Water</a>	Subgrader Trimmer	\$82.88	<a href="#">15J</a>	<a href="#">11G</a>	<a href="#">8X</a>	<a href="#">View</a>
Skagit	<a href="#">Power Equipment Operators-Underground Sewer &amp; Water</a>	Tower Bucket Elevators	\$82.25	<a href="#">15J</a>	<a href="#">11G</a>	<a href="#">8X</a>	<a href="#">View</a>
Skagit	<a href="#">Power Equipment Operators-Underground Sewer &amp; Water</a>	Tower Crane: over 175' through 250' in height, base to boom	\$85.66	<a href="#">7A</a>	<a href="#">11H</a>	<a href="#">8X</a>	<a href="#">View</a>
Skagit	<a href="#">Power Equipment Operators-Underground Sewer &amp; Water</a>	Tower crane: up to 175' in height base to boom	\$84.77	<a href="#">7A</a>	<a href="#">11H</a>	<a href="#">8X</a>	<a href="#">View</a>
Skagit	<a href="#">Power Equipment Operators-Underground Sewer &amp; Water</a>	Tower Cranes: over 250' in height from base to boom	\$86.48	<a href="#">7A</a>	<a href="#">11H</a>	<a href="#">8X</a>	<a href="#">View</a>
Skagit	<a href="#">Power Equipment Operators-Underground Sewer &amp; Water</a>	Transporters, All Track Or Truck Type	\$83.62	<a href="#">15J</a>	<a href="#">11G</a>	<a href="#">8X</a>	<a href="#">View</a>
Skagit	<a href="#">Power Equipment Operators-Underground Sewer &amp; Water</a>	Trenching Machines	\$82.25	<a href="#">15J</a>	<a href="#">11G</a>	<a href="#">8X</a>	<a href="#">View</a>
Skagit	<a href="#">Power Equipment Operators-Underground Sewer &amp; Water</a>	Truck Crane Oiler/Driver: 100 tons and over	\$83.20	<a href="#">7A</a>	<a href="#">11H</a>	<a href="#">8X</a>	<a href="#">View</a>
Skagit	<a href="#">Power Equipment Operators-Underground Sewer &amp; Water</a>	Truck crane oiler/driver: under 100 tons	\$82.56	<a href="#">7A</a>	<a href="#">11H</a>	<a href="#">8X</a>	<a href="#">View</a>
Skagit	<a href="#">Power Equipment Operators-Underground Sewer &amp; Water</a>	Truck Mount Portable Conveyor	\$82.88	<a href="#">15J</a>	<a href="#">11G</a>	<a href="#">8X</a>	<a href="#">View</a>
Skagit	<a href="#">Power Equipment Operators-Underground Sewer &amp; Water</a>	Vac Truck (Vactor Guzzler, Hydro Excavator)	\$82.88	<a href="#">15J</a>	<a href="#">11G</a>	<a href="#">8X</a>	<a href="#">View</a>
Skagit	<a href="#">Power Equipment Operators-Underground Sewer &amp; Water</a>	Welder	\$83.62	<a href="#">15J</a>	<a href="#">11G</a>	<a href="#">8X</a>	<a href="#">View</a>
Skagit	<a href="#">Power Equipment Operators-Underground Sewer &amp; Water</a>	Wheel Tractors, Farmall Type	\$78.65	<a href="#">15J</a>	<a href="#">11G</a>	<a href="#">8X</a>	<a href="#">View</a>
Skagit	<a href="#">Power Equipment Operators-Underground Sewer &amp; Water</a>	Yo Yo Pay Dozer	\$82.88	<a href="#">15J</a>	<a href="#">11G</a>	<a href="#">8X</a>	<a href="#">View</a>
Skagit	<a href="#">Power Line Clearance Tree Trimmers</a>	Journey Level In Charge	\$57.22	<a href="#">5A</a>	<a href="#">4A</a>		<a href="#">View</a>
Skagit	<a href="#">Power Line Clearance Tree Trimmers</a>	Spray Person	\$54.32	<a href="#">5A</a>	<a href="#">4A</a>		<a href="#">View</a>

Skagit	<a href="#">Power Line Clearance Tree Trimmers</a>	Tree Equipment Operator	\$57.22	<a href="#">5A</a>	<a href="#">4A</a>		<a href="#">View</a>
Skagit	<a href="#">Power Line Clearance Tree Trimmers</a>	Tree Trimmer	\$51.18	<a href="#">5A</a>	<a href="#">4A</a>		<a href="#">View</a>
Skagit	<a href="#">Power Line Clearance Tree Trimmers</a>	Tree Trimmer Groundperson	\$38.99	<a href="#">5A</a>	<a href="#">4A</a>		<a href="#">View</a>
Skagit	<a href="#">Refrigeration &amp; Air Conditioning Mechanics</a>	Journey Level	\$89.21	<a href="#">5A</a>	<a href="#">1G</a>		<a href="#">View</a>
Skagit	<a href="#">Residential Brick Mason</a>	Journey Level	\$32.30		<a href="#">1</a>		<a href="#">View</a>
Skagit	<a href="#">Residential Carpenters</a>	Journey Level	\$32.48		<a href="#">1</a>		<a href="#">View</a>
Skagit	<a href="#">Residential Cement Masons</a>	Journey Level	\$20.67		<a href="#">1</a>		<a href="#">View</a>
Skagit	<a href="#">Residential Drywall Applicators</a>	Journey Level	\$49.92	<a href="#">15J</a>	<a href="#">4C</a>		<a href="#">View</a>
Skagit	<a href="#">Residential Drywall Tapers</a>	Journey Level	\$34.10		<a href="#">1</a>		<a href="#">View</a>
Skagit	<a href="#">Residential Electricians</a>	Journey Level	\$46.91	<a href="#">7F</a>	<a href="#">1D</a>		<a href="#">View</a>
Skagit	<a href="#">Residential Glaziers</a>	Journey Level	\$54.00	<a href="#">7L</a>	<a href="#">1H</a>		<a href="#">View</a>
Skagit	<a href="#">Residential Insulation Applicators</a>	Journey Level	\$23.91		<a href="#">1</a>		<a href="#">View</a>
Skagit	<a href="#">Residential Laborers</a>	Journey Level	\$23.64		<a href="#">1</a>		<a href="#">View</a>
Skagit	<a href="#">Residential Marble Setters</a>	Journey Level	\$32.30		<a href="#">1</a>		<a href="#">View</a>
Skagit	<a href="#">Residential Painters</a>	Journey Level	\$24.50		<a href="#">1</a>		<a href="#">View</a>
Skagit	<a href="#">Residential Plumbers &amp; Pipefitters</a>	Journey Level	\$55.70	<a href="#">5A</a>	<a href="#">1G</a>		<a href="#">View</a>
Skagit	<a href="#">Residential Refrigeration &amp; Air Conditioning Mechanics</a>	Journey Level	\$96.42	<a href="#">7F</a>	<a href="#">1E</a>		<a href="#">View</a>
Skagit	<a href="#">Residential Sheet Metal Workers</a>	Journey Level	\$24.60		<a href="#">1</a>		<a href="#">View</a>
Skagit	<a href="#">Residential Soft Floor Layers</a>	Journey Level	\$30.31		<a href="#">1</a>		<a href="#">View</a>
Skagit	<a href="#">Residential Sprinkler Fitters (Fire Protection)</a>	Journey Level	\$37.16		<a href="#">1</a>		<a href="#">View</a>
Skagit	<a href="#">Residential Stone Masons</a>	Journey Level	\$32.30		<a href="#">1</a>		<a href="#">View</a>
Skagit	<a href="#">Residential Terrazzo Workers</a>	Journey Level	\$32.30		<a href="#">1</a>		<a href="#">View</a>
Skagit	<a href="#">Residential Terrazzo/Tile Finishers</a>	Journey Level	\$35.85		<a href="#">1</a>		<a href="#">View</a>
Skagit	<a href="#">Residential Tile Setters</a>	Journey Level	\$32.30		<a href="#">1</a>		<a href="#">View</a>
Skagit	<a href="#">Roofers</a>	Journey Level	\$64.45	<a href="#">5A</a>	<a href="#">3H</a>		<a href="#">View</a>
Skagit	<a href="#">Roofers</a>	Using Irritable Bituminous Materials	\$67.39	<a href="#">5A</a>	<a href="#">3H</a>		<a href="#">View</a>
Skagit	<a href="#">Sheet Metal Workers</a>	Journey Level (Field or Shop)	\$92.96	<a href="#">7F</a>	<a href="#">1E</a>		<a href="#">View</a>
Skagit	<a href="#">Shipbuilding &amp; Ship Repair</a>	New Construction Boilermaker	\$51.85	<a href="#">7X</a>	<a href="#">4J</a>		<a href="#">View</a>
Skagit	<a href="#">Shipbuilding &amp; Ship Repair</a>	New Construction Carpenter	\$51.85	<a href="#">7X</a>	<a href="#">4J</a>		<a href="#">View</a>
Skagit	<a href="#">Shipbuilding &amp; Ship Repair</a>	New Construction Crane Operator	\$43.16	<a href="#">7V</a>	<a href="#">1</a>		<a href="#">View</a>
Skagit	<a href="#">Shipbuilding &amp; Ship Repair</a>	New Construction Electrician	\$51.85	<a href="#">7X</a>	<a href="#">4J</a>		<a href="#">View</a>
Skagit	<a href="#">Shipbuilding &amp; Ship Repair</a>	New Construction Heat & Frost Insulator	\$87.15	<a href="#">15H</a>	<a href="#">11C</a>		<a href="#">View</a>
Skagit	<a href="#">Shipbuilding &amp; Ship Repair</a>	New Construction Laborer	\$51.85	<a href="#">7X</a>	<a href="#">4J</a>		<a href="#">View</a>
Skagit	<a href="#">Shipbuilding &amp; Ship Repair</a>	New Construction Machinist	\$51.85	<a href="#">7X</a>	<a href="#">4J</a>		<a href="#">View</a>
Skagit	<a href="#">Shipbuilding &amp; Ship Repair</a>	New Construction Operating Engineer	\$43.16	<a href="#">7V</a>	<a href="#">1</a>		<a href="#">View</a>
Skagit	<a href="#">Shipbuilding &amp; Ship Repair</a>	New Construction Painter	\$51.95	<a href="#">7X</a>	<a href="#">4J</a>		<a href="#">View</a>
Skagit	<a href="#">Shipbuilding &amp; Ship Repair</a>	New Construction Pipefitter	\$51.85	<a href="#">7X</a>	<a href="#">4J</a>		<a href="#">View</a>
Skagit	<a href="#">Shipbuilding &amp; Ship Repair</a>	New Construction Rigger	\$51.85	<a href="#">7X</a>	<a href="#">4J</a>		<a href="#">View</a>
Skagit	<a href="#">Shipbuilding &amp; Ship Repair</a>	New Construction Sheet Metal	\$51.85	<a href="#">7X</a>	<a href="#">4J</a>		<a href="#">View</a>
Skagit	<a href="#">Shipbuilding &amp; Ship Repair</a>	New Construction Shipwright	\$51.85	<a href="#">7X</a>	<a href="#">4J</a>		<a href="#">View</a>
Skagit	<a href="#">Shipbuilding &amp; Ship Repair</a>	New Construction Warehouse/Teamster	\$43.16	<a href="#">7V</a>	<a href="#">1</a>		<a href="#">View</a>
Skagit	<a href="#">Shipbuilding &amp; Ship Repair</a>	New Construction Welder / Burner	\$51.85	<a href="#">7X</a>	<a href="#">4J</a>		<a href="#">View</a>
Skagit	<a href="#">Shipbuilding &amp; Ship Repair</a>	Ship Repair Boilermaker	\$51.85	<a href="#">7X</a>	<a href="#">4J</a>		<a href="#">View</a>



Skagit	<a href="#">Shipbuilding &amp; Ship Repair</a>	Ship Repair Carpenter	\$51.85	<u>7X</u>	<u>4J</u>		<a href="#">View</a>
Skagit	<a href="#">Shipbuilding &amp; Ship Repair</a>	Ship Repair Crane Operator	\$45.06	<u>7Y</u>	<u>4K</u>		<a href="#">View</a>
Skagit	<a href="#">Shipbuilding &amp; Ship Repair</a>	Ship Repair Electrician	\$51.85	<u>7X</u>	<u>4J</u>		<a href="#">View</a>
Skagit	<a href="#">Shipbuilding &amp; Ship Repair</a>	Ship Repair Heat & Frost Insulator	\$87.15	<u>15H</u>	<u>11C</u>		<a href="#">View</a>
Skagit	<a href="#">Shipbuilding &amp; Ship Repair</a>	Ship Repair Laborer	\$51.85	<u>7X</u>	<u>4J</u>		<a href="#">View</a>
Skagit	<a href="#">Shipbuilding &amp; Ship Repair</a>	Ship Repair Machinist	\$51.85	<u>7X</u>	<u>4J</u>		<a href="#">View</a>
Skagit	<a href="#">Shipbuilding &amp; Ship Repair</a>	Ship Repair Operating Engineer	\$45.06	<u>7Y</u>	<u>4K</u>		<a href="#">View</a>
Skagit	<a href="#">Shipbuilding &amp; Ship Repair</a>	Ship Repair Painter	\$51.95	<u>7X</u>	<u>4J</u>		<a href="#">View</a>
Skagit	<a href="#">Shipbuilding &amp; Ship Repair</a>	Ship Repair Pipefitter	\$51.85	<u>7X</u>	<u>4J</u>		<a href="#">View</a>
Skagit	<a href="#">Shipbuilding &amp; Ship Repair</a>	Ship Repair Rigger	\$51.85	<u>7X</u>	<u>4J</u>		<a href="#">View</a>
Skagit	<a href="#">Shipbuilding &amp; Ship Repair</a>	Ship Repair Sheet Metal	\$51.85	<u>7X</u>	<u>4J</u>		<a href="#">View</a>
Skagit	<a href="#">Shipbuilding &amp; Ship Repair</a>	Ship Repair Shipwright	\$51.85	<u>7X</u>	<u>4J</u>		<a href="#">View</a>
Skagit	<a href="#">Shipbuilding &amp; Ship Repair</a>	Ship Repair Warehouse / Teamster	\$45.06	<u>7Y</u>	<u>4K</u>		<a href="#">View</a>
Skagit	<a href="#">Sign Makers &amp; Installers (Electrical)</a>	Journey Level	\$16.28		<u>1</u>		<a href="#">View</a>
Skagit	<a href="#">Sign Makers &amp; Installers (Non-Electrical)</a>	Journey Level	\$16.28		<u>1</u>		<a href="#">View</a>
Skagit	<a href="#">Soft Floor Layers</a>	Journey Level	\$66.32	<u>15J</u>	<u>4C</u>		<a href="#">View</a>
Skagit	<a href="#">Solar Controls For Windows</a>	Journey Level	\$16.28		<u>1</u>		<a href="#">View</a>
Skagit	<a href="#">Sprinkler Fitters (Fire Protection)</a>	Journey Level	\$95.49	<u>5C</u>	<u>1X</u>		<a href="#">View</a>
Skagit	<a href="#">Stage Rigging Mechanics (Non Structural)</a>	Journey Level	\$16.28		<u>1</u>		<a href="#">View</a>
Skagit	<a href="#">Stone Masons</a>	Journey Level	\$69.07	<u>7E</u>	<u>1N</u>		<a href="#">View</a>
Skagit	<a href="#">Street And Parking Lot Sweeper Workers</a>	Journey Level	\$16.28		<u>1</u>		<a href="#">View</a>
Skagit	<a href="#">Surveyors</a>	Assistant Construction Site Surveyor	\$82.56	<u>7A</u>	<u>11H</u>	<u>8X</u>	<a href="#">View</a>
Skagit	<a href="#">Surveyors</a>	Chainman	\$78.95	<u>7A</u>	<u>11H</u>	<u>8X</u>	<a href="#">View</a>
Skagit	<a href="#">Surveyors</a>	Construction Site Surveyor	\$83.95	<u>7A</u>	<u>11H</u>	<u>8X</u>	<a href="#">View</a>
Skagit	<a href="#">Surveyors</a>	Drone Operator (when used in conjunction with survey work only)	\$78.95	<u>7A</u>	<u>11H</u>	<u>8X</u>	<a href="#">View</a>
Skagit	<a href="#">Surveyors</a>	Ground Penetrating Radar Operator	\$78.95	<u>7A</u>	<u>11H</u>	<u>8X</u>	<a href="#">View</a>
Skagit	<a href="#">Telecommunication Technicians</a>	Telecom Technician Journey Level	\$53.94	<u>5B</u>	<u>1B</u>		<a href="#">View</a>
Skagit	<a href="#">Telephone Line Construction - Outside</a>	Cable Splicer	\$40.36	<u>5A</u>	<u>2B</u>		<a href="#">View</a>
Skagit	<a href="#">Telephone Line Construction - Outside</a>	Hole Digger/Ground Person	\$26.92	<u>5A</u>	<u>2B</u>		<a href="#">View</a>
Skagit	<a href="#">Telephone Line Construction - Outside</a>	Telephone Equipment Operator (Light)	\$33.74	<u>5A</u>	<u>2B</u>		<a href="#">View</a>
Skagit	<a href="#">Telephone Line Construction - Outside</a>	Telephone Lineperson	\$38.15	<u>5A</u>	<u>2B</u>		<a href="#">View</a>
Skagit	<a href="#">Terrazzo Workers</a>	Journey Level	\$62.36	<u>7E</u>	<u>1N</u>		<a href="#">View</a>
Skagit	<a href="#">Tile Setters</a>	Journey Level	\$62.36	<u>7E</u>	<u>1N</u>		<a href="#">View</a>
Skagit	<a href="#">Tile, Marble &amp; Terrazzo Finishers</a>	Finisher	\$53.19	<u>7E</u>	<u>1N</u>		<a href="#">View</a>
Skagit	<a href="#">Traffic Control Stripers</a>	Journey Level	\$89.54	<u>15L</u>	<u>1K</u>		<a href="#">View</a>
Skagit	<a href="#">Truck Drivers</a>	Asphalt Mix Over 16 Yards	\$74.20	<u>15J</u>	<u>11M</u>	<u>8L</u>	<a href="#">View</a>
Skagit	<a href="#">Truck Drivers</a>	Asphalt Mix To 16 Yards	\$73.36	<u>15J</u>	<u>11M</u>	<u>8L</u>	<a href="#">View</a>
Skagit	<a href="#">Truck Drivers</a>	Dump Truck	\$73.36	<u>15J</u>	<u>11M</u>	<u>8L</u>	<a href="#">View</a>
Skagit	<a href="#">Truck Drivers</a>	Dump Truck & Trailer	\$74.20	<u>15J</u>	<u>11M</u>	<u>8L</u>	<a href="#">View</a>
Skagit	<a href="#">Truck Drivers</a>	Other Trucks	\$74.20	<u>15J</u>	<u>11M</u>	<u>8L</u>	<a href="#">View</a>
Skagit	<a href="#">Truck Drivers - Ready Mix</a>	Transit Mix	\$74.20	<u>15J</u>	<u>11M</u>	<u>8L</u>	<a href="#">View</a>
Skagit	<a href="#">Well Drillers &amp; Irrigation Pump Installers</a>	Irrigation Pump Installer	\$16.28		<u>1</u>		<a href="#">View</a>

Skagit	<a href="#">Well Drillers &amp; Irrigation Pump Installers</a>	Oiler	\$16.28		<u>1</u>		<a href="#">View</a>
Skagit	<a href="#">Well Drillers &amp; Irrigation Pump Installers</a>	Well Driller	\$16.28		<u>1</u>		<a href="#">View</a>

State of Washington  
 Department of Labor & Industries  
 Prevailing Wage Section - Telephone 360-902-5335  
 PO Box 44540, Olympia, WA 98504-4540

**Washington State Prevailing Wage**

The PREVAILING WAGES listed here include both the hourly wage rate and the hourly rate of fringe benefits. On public works projects, worker's wage and benefit rates must add to not less than this total. A brief description of overtime calculation requirements are provided on the Benefit Code Key.

**Apprentice Level Prevailing Wage Rates for Skagit County and Flaggers Trade for the  
 Effective Date: 8/6/2024**

<u>Step</u>	<u>Occupation</u>	<u>Begin Hours</u>	<u>End Hours</u>	<u>Apprentice Wage</u>	<b>Holiday</b>	<b>Overtime</b>	<b>Note</b>
Step 1	Flagger/Western WA	1	1000	\$41.26	<u>15J</u>	<u>11P</u>	<u>8Y</u>
Step 2	Flagger/Western WA	1001	2000	\$45.71	<u>15J</u>	<u>11P</u>	<u>8Y</u>
Step 3	Flagger/Western WA	2001	3000	\$50.07	<u>15J</u>	<u>11P</u>	<u>8Y</u>
Step 4	Flagger/Western WA	3001	4000	\$50.07	<u>15J</u>	<u>11P</u>	<u>8Y</u>
Step 5	Flagger/Western WA	4001	5000	\$50.07	<u>15J</u>	<u>11P</u>	<u>8Y</u>
Step 6	Flagger/Western WA	5001	6000	\$50.07	<u>15J</u>	<u>11P</u>	<u>8Y</u>

State of Washington  
 Department of Labor & Industries  
 Prevailing Wage Section - Telephone 360-902-5335  
 PO Box 44540, Olympia, WA 98504-4540

**Washington State Prevailing Wage**

The PREVAILING WAGES listed here include both the hourly wage rate and the hourly rate of fringe benefits. On public works projects, worker's wage and benefit rates must add to not less than this total. A brief description of overtime calculation requirements are provided on the Benefit Code Key.

**Apprentice Level Prevailing Wage Rates for Skagit County and Laborers Trade for the  
 Effective Date: 8/6/2024**

<u>Step</u>	<u>Occupation</u>	<u>Begin Hours</u>	<u>End Hours</u>	<u>Apprentice Wage</u>	<u>Holiday</u>	<u>Overtime</u>	<u>Note</u>
Step 1	Window Washer, Cleaner/Western WA	1	1000	\$41.26	<u>15J</u>	<u>11P</u>	<u>8Y</u>
Step 2	Window Washer, Cleaner/Western WA	1001	2000	\$45.51	<u>15J</u>	<u>11P</u>	<u>8Y</u>
Step 3	Window Washer, Cleaner/Western WA	2001	3000	\$45.51	<u>15J</u>	<u>11P</u>	<u>8Y</u>
Step 4	Window Washer, Cleaner/Western WA	3001	4000	\$45.51	<u>15J</u>	<u>11P</u>	<u>8Y</u>
Step 5	Window Washer, Cleaner/Western WA	4001	5000	\$45.51	<u>15J</u>	<u>11P</u>	<u>8Y</u>
Step 6	Window Washer, Cleaner/Western WA	5001	6000	\$45.51	<u>15J</u>	<u>11P</u>	<u>8Y</u>
Step 1	Laborer/Western WA	1	1000	\$41.26	<u>15J</u>	<u>11P</u>	<u>8Y</u>
Step 2	Laborer/Western WA	1001	2000	\$45.71	<u>15J</u>	<u>11P</u>	<u>8Y</u>
Step 3	Laborer/Western WA	2001	3000	\$50.16	<u>15J</u>	<u>11P</u>	<u>8Y</u>
Step 4	Laborer/Western WA	3001	4000	\$52.39	<u>15J</u>	<u>11P</u>	<u>8Y</u>
Step 5	Laborer/Western WA	4001	5000	\$54.62	<u>15J</u>	<u>11P</u>	<u>8Y</u>
Step 6	Laborer/Western WA	5001	6000	\$56.84	<u>15J</u>	<u>11P</u>	<u>8Y</u>



State of Washington  
 Department of Labor & Industries  
 Prevailing Wage Section - Telephone 360-902-5335  
 PO Box 44540, Olympia, WA 98504-4540

**Washington State Prevailing Wage**

The PREVAILING WAGES listed here include both the hourly wage rate and the hourly rate of fringe benefits. On public works projects, worker's wage and benefit rates must add to not less than this total. A brief description of overtime calculation requirements are provided on the Benefit Code Key.

**Apprentice Level Prevailing Wage Rates for Skagit County and Laborers - Underground Sewer & Water Trade for the Effective Date: 8/6/2024**

<u>Step</u>	<u>Occupation</u>	<u>Begin Hours</u>	<u>End Hours</u>	<u>Apprentice Wage</u>	<b>Holiday</b>	<b>Overtime</b>	<b>Note</b>
Step 1	Laborers Underground Sewer/Western WA	1	1000	\$41.26	<u>15J</u>	<u>11P</u>	<u>8Y</u>
Step 2	Laborers Underground Sewer/Western WA	1001	2000	\$45.71	<u>15J</u>	<u>11P</u>	<u>8Y</u>
Step 3	Laborers Underground Sewer/Western WA	2001	3000	\$50.16	<u>15J</u>	<u>11P</u>	<u>8Y</u>
Step 4	Laborers Underground Sewer/Western WA	3001	4000	\$52.39	<u>15J</u>	<u>11P</u>	<u>8Y</u>
Step 5	Laborers Underground Sewer/Western WA	4001	5000	\$54.62	<u>15J</u>	<u>11P</u>	<u>8Y</u>
Step 6	Laborers Underground Sewer/Western WA	5001	6000	\$56.84	<u>15J</u>	<u>11P</u>	<u>8Y</u>

State of Washington  
 Department of Labor & Industries  
 Prevailing Wage Section - Telephone 360-902-5335  
 PO Box 44540, Olympia, WA 98504-4540

**Washington State Prevailing Wage**

The PREVAILING WAGES listed here include both the hourly wage rate and the hourly rate of fringe benefits. On public works projects, worker's wage and benefit rates must add to not less than this total. A brief description of overtime calculation requirements are provided on the Benefit Code Key.

**Apprentice Level Prevailing Wage Rates for Skagit County and Power Equipment Operators Trade for the Effective Date: 8/6/2024**

<u>Step</u>	<u>Occupation</u>	<u>Begin Hours</u>	<u>End Hours</u>	<u>Apprentice Wage</u>	<u>Holiday</u>	<u>Overtime</u>	<u>Note</u>
Step 1	Constr Equipment Operator	1	1000	\$62.41	<u>15J</u>	<u>11G</u>	<u>8X</u>
Step 2	Constr Equipment Operator	1001	2000	\$65.25	<u>15J</u>	<u>11G</u>	<u>8X</u>
Step 3	Constr Equipment Operator	2001	3000	\$70.33	<u>15J</u>	<u>11G</u>	<u>8X</u>
Step 4	Constr Equipment Operator	3001	4000	\$70.91	<u>15J</u>	<u>11G</u>	<u>8X</u>
Step 5	Constr Equipment Operator	4001	5000	\$76.58	<u>15J</u>	<u>11G</u>	<u>8X</u>
Step 6	Constr Equipment Operator	5001	6000	\$79.42	<u>15J</u>	<u>11G</u>	<u>8X</u>
Step 1	Heavy Duty Repair Mechanic	1	1000	\$62.41	<u>15J</u>	<u>11G</u>	<u>8X</u>
Step 2	Heavy Duty Repair Mechanic	1001	2000	\$65.25	<u>15J</u>	<u>11G</u>	<u>8X</u>
Step 3	Heavy Duty Repair Mechanic	2001	3000	\$70.33	<u>15J</u>	<u>11G</u>	<u>8X</u>
Step 4	Heavy Duty Repair Mechanic	3001	4000	\$70.91	<u>15J</u>	<u>11G</u>	<u>8X</u>
Step 5	Heavy Duty Repair Mechanic	4001	5000	\$76.58	<u>15J</u>	<u>11G</u>	<u>8X</u>
Step 6	Heavy Duty Repair Mechanic	5001	6000	\$79.42	<u>15J</u>	<u>11G</u>	<u>8X</u>
Step 1	Hoisting Engineer	1	1000	\$62.61	<u>7A</u>	<u>11H</u>	<u>8X</u>
Step 2	Hoisting Engineer	1001	2000	\$65.46	<u>7A</u>	<u>11H</u>	<u>8X</u>
Step 3	Hoisting Engineer	2001	3000	\$68.31	<u>7A</u>	<u>11H</u>	<u>8X</u>
Step 4	Hoisting Engineer	3001	4000	\$71.16	<u>7A</u>	<u>11H</u>	<u>8X</u>
Step 5	Hoisting Engineer	4001	5000	\$76.86	<u>7A</u>	<u>11H</u>	<u>8X</u>
Step 6	Hoisting Engineer	5001	6000	\$79.71	<u>7A</u>	<u>11H</u>	<u>8X</u>

State of Washington  
 Department of Labor & Industries  
 Prevailing Wage Section - Telephone 360-902-5335  
 PO Box 44540, Olympia, WA 98504-4540

**Washington State Prevailing Wage**

The PREVAILING WAGES listed here include both the hourly wage rate and the hourly rate of fringe benefits. On public works projects, worker's wage and benefit rates must add to not less than this total. A brief description of overtime calculation requirements are provided on the Benefit Code Key.

**Apprentice Level Prevailing Wage Rates for Skagit County and Power Equipment Operators- Underground Sewer & Water Trade for the Effective Date: 8/6/2024**

<u>Step</u>	<u>Occupation</u>	<u>Begin Hours</u>	<u>End Hours</u>	<u>Apprentice Wage</u>	<u>Holiday</u>	<u>Overtime</u>	<u>Note</u>
Step 1	Constr Equipment Operator	1	1000	\$62.41	<u>15J</u>	<u>11G</u>	<u>8X</u>
Step 2	Constr Equipment Operator	1001	2000	\$65.25	<u>15J</u>	<u>11G</u>	<u>8X</u>
Step 3	Constr Equipment Operator	2001	3000	\$70.33	<u>15J</u>	<u>11G</u>	<u>8X</u>
Step 4	Constr Equipment Operator	3001	4000	\$70.91	<u>15J</u>	<u>11G</u>	<u>8X</u>
Step 5	Constr Equipment Operator	4001	5000	\$76.58	<u>15J</u>	<u>11G</u>	<u>8X</u>
Step 6	Constr Equipment Operator	5001	6000	\$79.42	<u>15J</u>	<u>11G</u>	<u>8X</u>
Step 1	Heavy Duty Repair Mechanic	1	1000	\$62.41	<u>15J</u>	<u>11G</u>	<u>8X</u>
Step 2	Heavy Duty Repair Mechanic	1001	2000	\$65.25	<u>15J</u>	<u>11G</u>	<u>8X</u>
Step 3	Heavy Duty Repair Mechanic	2001	3000	\$70.33	<u>15J</u>	<u>11G</u>	<u>8X</u>
Step 4	Heavy Duty Repair Mechanic	3001	4000	\$70.91	<u>15J</u>	<u>11G</u>	<u>8X</u>
Step 5	Heavy Duty Repair Mechanic	4001	5000	\$76.58	<u>15J</u>	<u>11G</u>	<u>8X</u>
Step 6	Heavy Duty Repair Mechanic	5001	6000	\$79.42	<u>15J</u>	<u>11G</u>	<u>8X</u>
Step 1	Hoisting Engineer	1	1000	\$62.61	<u>7A</u>	<u>11H</u>	<u>8X</u>
Step 2	Hoisting Engineer	1001	2000	\$65.46	<u>7A</u>	<u>11H</u>	<u>8X</u>
Step 3	Hoisting Engineer	2001	3000	\$68.31	<u>7A</u>	<u>11H</u>	<u>8X</u>
Step 4	Hoisting Engineer	3001	4000	\$71.16	<u>7A</u>	<u>11H</u>	<u>8X</u>
Step 5	Hoisting Engineer	4001	5000	\$76.86	<u>7A</u>	<u>11H</u>	<u>8X</u>
Step 6	Hoisting Engineer	5001	6000	\$79.71	<u>7A</u>	<u>11H</u>	<u>8X</u>

State of Washington  
 Department of Labor & Industries  
 Prevailing Wage Section - Telephone 360-902-5335  
 PO Box 44540, Olympia, WA 98504-4540

**Washington State Prevailing Wage**

The PREVAILING WAGES listed here include both the hourly wage rate and the hourly rate of fringe benefits. On public works projects, worker's wage and benefit rates must add to not less than this total. A brief description of overtime calculation requirements are provided on the Benefit Code Key.

**Apprentice Level Prevailing Wage Rates for Skagit County and Surveyors Trade for the  
 Effective Date: 8/6/2024**

<u>Step</u>	<u>Occupation</u>	<u>Begin Hours</u>	<u>End Hours</u>	<u>Apprentice Wage</u>	<b>Holiday</b>	<b>Overtime</b>	<b>Note</b>
Step 1	Construction Site Surveyor	1	1000	\$62.61	<u>7A</u>	<u>11H</u>	<u>8X</u>
Step 2	Construction Site Surveyor	1001	2000	\$65.46	<u>7A</u>	<u>11H</u>	<u>8X</u>
Step 3	Construction Site Surveyor	2001	3000	\$68.31	<u>7A</u>	<u>11H</u>	<u>8X</u>
Step 4	Construction Site Surveyor	3001	4000	\$71.16	<u>7A</u>	<u>11H</u>	<u>8X</u>
Step 5	Construction Site Surveyor	4001	5000	\$76.86	<u>7A</u>	<u>11H</u>	<u>8X</u>
Step 6	Construction Site Surveyor	5001	6000	\$79.71	<u>7A</u>	<u>11H</u>	<u>8X</u>

State of Washington  
Department of Labor & Industries  
Prevailing Wage Section - Telephone 360-902-5335  
PO Box 44540, Olympia, WA 98504-4540

**Washington State Prevailing Wage**

The PREVAILING WAGES listed here include both the hourly wage rate and the hourly rate of fringe benefits. On public works projects, worker's wage and benefit rates must add to not less than this total. A brief description of overtime calculation requirements are provided on the Benefit Code Key.

---

**Apprentice Level Prevailing Wage Rates for Skagit County and Truck Drivers Trade for the  
Effective Date: 8/6/2024**

<u>Step</u>	<u>Occupation</u>	<u>Begin Hours</u>	<u>End Hours</u>	<u>Apprentice Wage</u>	<b>Holiday</b>	<b>Overtime</b>	<b>Note</b>
Step 1	Truck Driver	1	1000	\$59.24	<u>15J</u>	<u>11M</u>	<u>8L</u>
Step 2	Truck Driver	1001	2000	\$64.22	<u>15J</u>	<u>11M</u>	<u>8L</u>
Step 3	Truck Driver	2001	3000	\$69.21	<u>15J</u>	<u>11M</u>	<u>8L</u>

State of Washington  
 Department of Labor & Industries  
 Prevailing Wage Section - Telephone 360-902-5335  
 PO Box 44540, Olympia, WA 98504-4540

**Washington State Prevailing Wage**

The PREVAILING WAGES listed here include both the hourly wage rate and the hourly rate of fringe benefits. On public works projects, worker's wage and benefit rates must add to not less than this total. A brief description of overtime calculation requirements are provided on the Benefit Code Key.

**Apprentice Level Prevailing Wage Rates for Skagit County and Truck Drivers - Ready Mix  
 Trade for the Effective Date: 8/6/2024**

<u>Step</u>	<u>Occupation</u>	<u>Begin Hours</u>	<u>End Hours</u>	<u>Apprentice Wage</u>	<b>Holiday</b>	<b>Overtime</b>	<b>Note</b>
Step 1	Truck Driver	1	1000	\$59.24	<u>15J</u>	<u>11M</u>	<u>8L</u>
Step 2	Truck Driver	1001	2000	\$64.22	<u>15J</u>	<u>11M</u>	<u>8L</u>
Step 3	Truck Driver	2001	3000	\$69.21	<u>15J</u>	<u>11M</u>	<u>8L</u>

**APPENDIX B**  
**PERMITS**



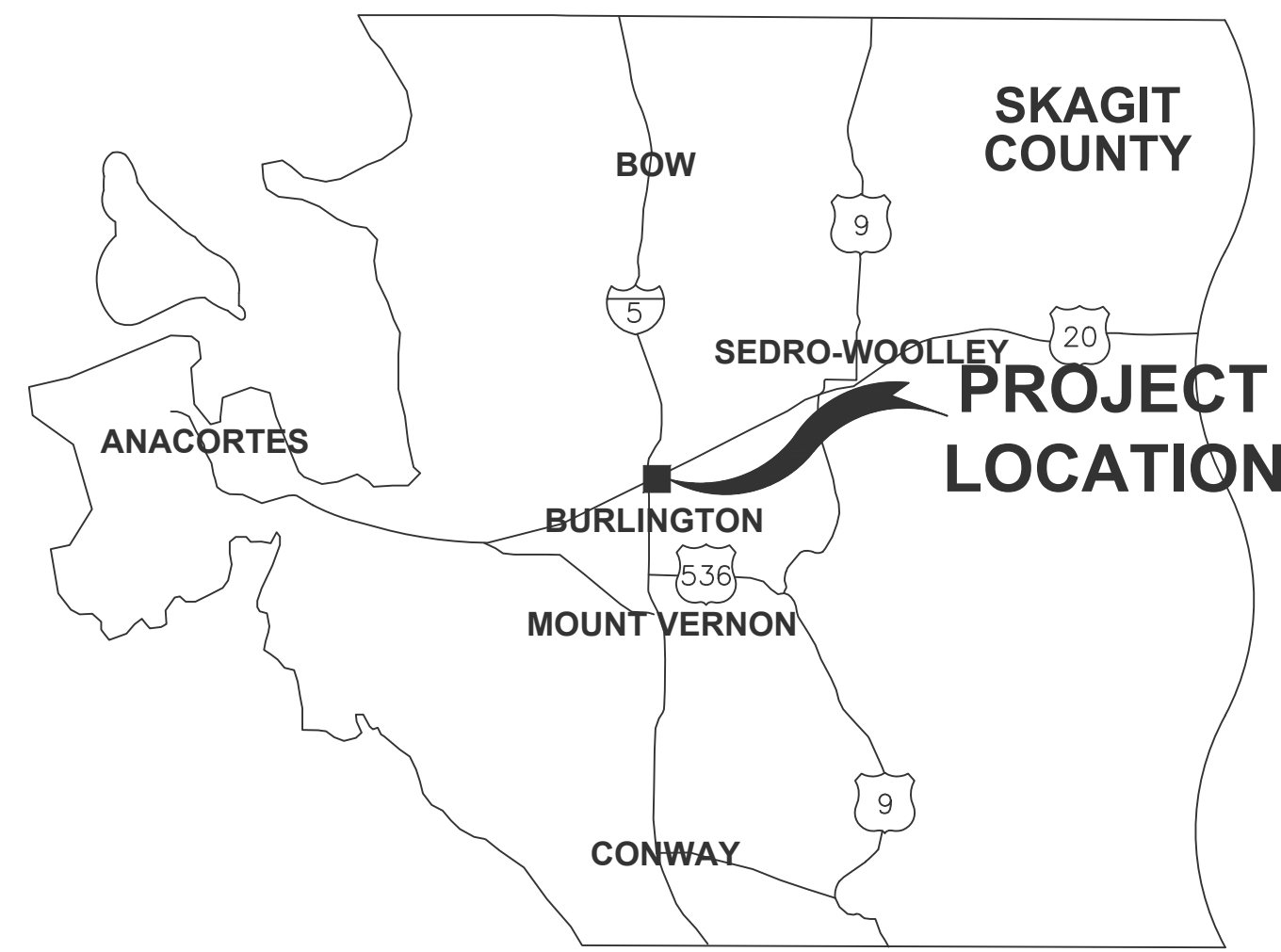

# NORTH BURLINGTON PIPELINE REPLACEMENT

BURLINGTON, SKAGIT COUNTY, WA

P.N. 03498

CP4804

MAY 1, 2024



PUBLIC UTILITY DISTRICT

NO. 1 OF SKAGIT COUNTY

## DISTRICT OFFICIALS

JOE LINDQUIST                      PRESIDENT  
ANDREW MILLER                  VICE PRESIDENT  
CORRIN HAMBURG                SECRETARY

GEORGE SIDHU, P.E.              GENERAL MANAGER  
MARK C. HANDZLIK, P.E.        ENGINEERING MANAGER  
MICHAEL FOX                        OPERATIONS MANAGER

## UTILITY CONTACTS

**CASCADE NATURAL GAS**  
1520 SOUTH 2nd STREET  
MOUNT VERNON, WA 98273  
CONTACT: JAMES HOBBS  
TEL: (360) 336-3876

**FRONTIER COMMUNICATION**  
595 PEASE ROAD  
BURLINGTON, WA 98233  
CONTACT: BRET MURDOCK  
TEL: (360) 707-0641

**COMCAST XFINITY**  
400 SEQUOIA DRIVE  
BELLINGHAM, WA 98226  
CONTACT: CASEY JONES  
TEL: (360) 527-8243

**ATT FIBER OPTICS**  
C/O SIENA ENGINEERING GROUP, INC.  
11241 WILLOW RD NE, SUITE 130  
REDMOND, WA 98052  
CONTACT: LOUIE VAN HOLLEBEKE  
TEL: (425) 896-9850

**PUGET SOUND ENERGY**  
PO BOX 90868 - MAIL STOP BOT01G  
BELLEVUE, WA 98009-0868  
CONTACT: CUSTOMER CONSTRUCTION SERVICES  
TEL: (888) 321-7779

## DRAWING INDEX

- COVER
- 1. LEGEND
- 2. GENERAL NOTES
- 3. SHUTDOWN MAP
- 4. BMP AND STORM DETAILS
- 5. E HAZEL AVE PLAN & PROFILE : STA 16+50 TO STA 21+00
- 6. E HAZEL AVE PLAN & PROFILE : STA 21+00 TO STA 26+80
- 7. N WALNUT ST PLAN & PROFILE : STA 80+00 TO STA 82+50
- 8. AVON AVE PLAN & PROFILE : STA 39+50 TO STA 44+50
- 9. AVON AVE PLAN & PROFILE : STA 44+50 TO STA 50+00
- 10. AVON AVE PLAN & PROFILE : STA 50+00 TO STA 55+50
- 11. AVON AVE PLAN & PROFILE : STA 55+50 TO STA 60+00
- 12. AVON AVE/MAGNOLIA AVE PLAN & PROFILE : STA 60+00 TO STA 63+00, STA 70+50 TO STA 72+00
- 13. MAGNOLIA AVE PLAN & PROFILE : STA 72+00 TO STA 76+26
- 14. N OAK ST PL PLAN & PROFILE : STA 89+50 TO STA 92+50
- 15. N CHERRY ST PLAN & PROFILE : STA 99+50 TO STA 103+50
- 16. N CHERRY ST PLAN & PROFILE : STA 103+50 TO STA 108+50
- 17. N CHERRY ST PLAN & PROFILE : STA 108+50 TO STA 112+80
- 18. N PINE ST PLAN & PROFILE : STA 120+50 TO STA 122+50
- 19. N ANACORTES ST PLAN & PROFILE : STA 130+00 TO STA 135+50
- 20. S WALNUT ST PLAN & PROFILE : STA 206+00 TO STA 211+50
- 21. N WALNUT ST PLAN & PROFILE : STA 211+50 TO STA 214+00
- 22. S ALLEY PLAN & PROFILE : STA 225+50 TO STA 228+50
- 23. S ALLEY PLAN & PROFILE : STA 228+50 TO STA 230+50
- 24. N ALLEY PLAN & PROFILE : STA 250+50 TO STA 253+84
- 25. S ALDER ST PLAN & PROFILE : STA 281+00 TO STA 286+00
- 26. S ALDER ST PLAN & PROFILE : STA 286+00 TO STA 291+50
- 27. DETAILS
- 28. DETAILS(CONTINUED)
- 29. TRAFFIC CONTROL

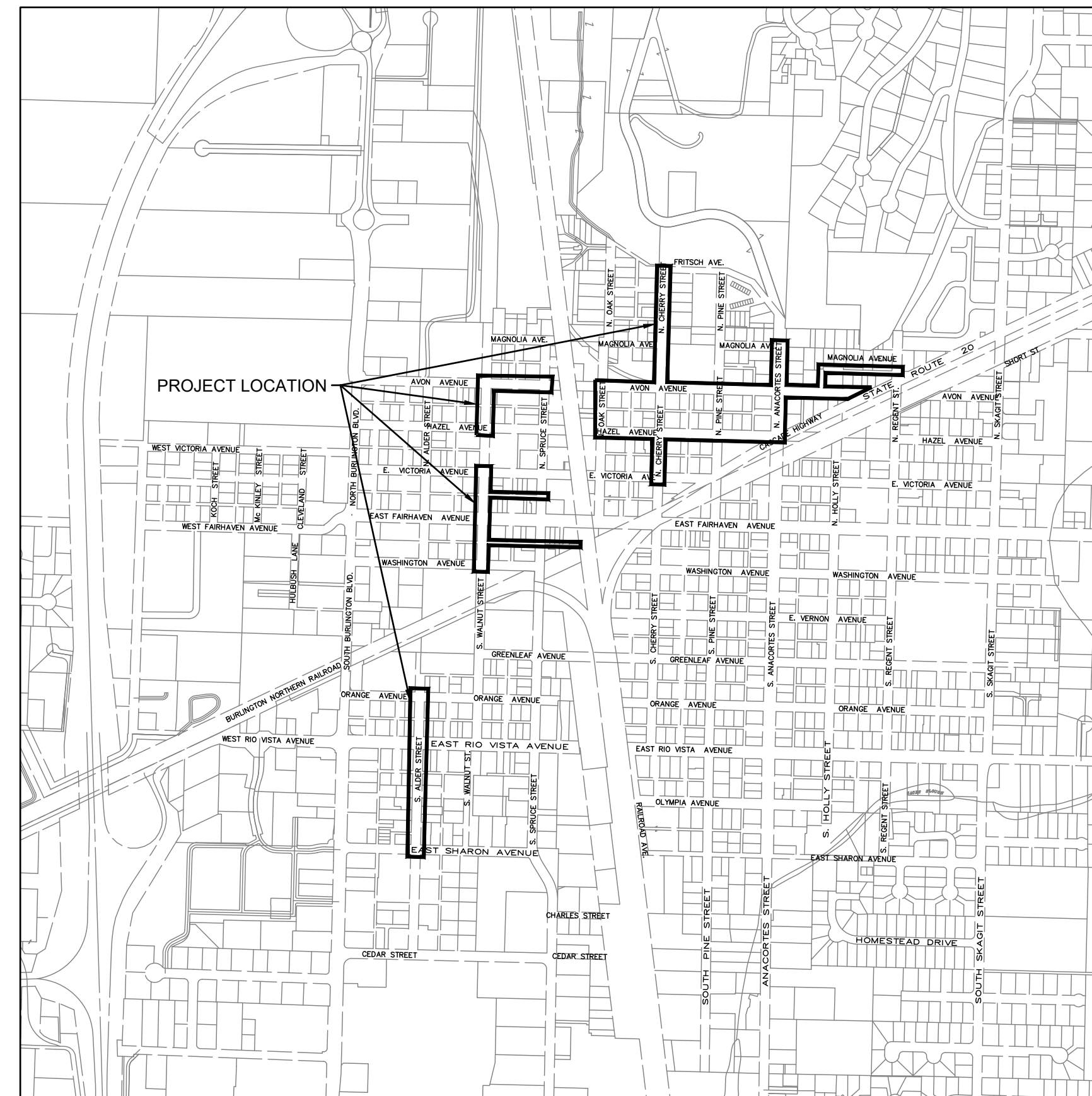

**VICINITY MAP**  
NOT TO SCALE

Approved Hydrant  
Per  
Fire Marshal  
07/12/2024 10:50:08 AM  
Kelly Blaine F.M.

APPROVED FOR CONSTRUCTION  
  
\_\_\_\_\_  
CHIEF OF FIRE PREVENTION                      DATE  
APPROVAL VOID ONE YEAR FROM DATE SHOWN

*Brian Dempsey* | 7/15/24  
APPROVED FOR CONSTRUCTION                      DATE  
CITY OF BURLINGTON ENGINEER

ISSUE	REVISIONS	BY	DATE
1.	30% DESIGN	MCH	11/20/23



DATUM: HOR: NAD 83 VERT: NAVD 88	DSGN BY: KAN DWN BY: KAN APPVD BY: MCH
DATE PRINTED: 5/1/24	SEC: 05.32 TWP: 34.35 N RGE: 04 E

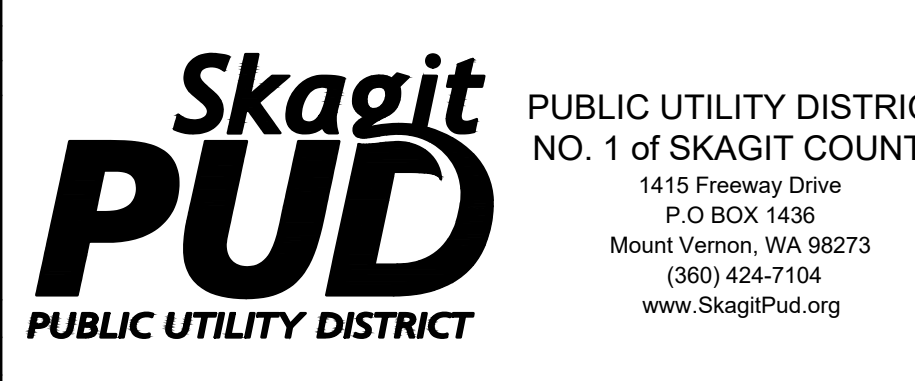

NORTH BURLINGTON PIPELINE REPLACEMENT COVER	
SCALE: NONE	JOB ID : CP4804
SHEET: COVER	





PUBLIC WORKS
833 S. Spruce Street
Burlington, WA 98233
(360) 755-9715 -- Office

RIGHT OF WAY

ISSUE DATE: 07/26/2024

Permit Number: ROW24-0036

APPLICANT: SKAGIT COUNTY PUD
1415 FREEWAY DR
MOUNT VERNON, WA 98273
360-391-9282

PRIMARY CONTRACTOR NAME A...

THIS PERMIT AUTHORIZES THE BELOW DESCRIBED WORK:

ROW - PUD replacement of approximately 4,000 lf of 2-inch, 4-inch & 6-inch CI/AC/PVC with 8-inch Ductile Iron Water Main

CONDITIONS AND COMMENTS APPLICABLE TO THIS PERMIT:

SCOPE OF WORK - #1 of 4 project areas for PUD water main replacement:

Avon: Oak to Anacortes; Hazel: Oak to Anacortes; Cherry: Victoria to Fritsch.

- 1. Work to begin in late summer/early fall 2024.
2. Provide 2 week notice in advance of construction to all property owners in proximity of work.
3. No open-cutting of street is permitted for the lateral lines (services to homes)
4. Any castings/iron that needs adjustment shall follow WSDOT specification 5-04 for flatness.
5. For surface restoration, match existing asphalt thickness or provide 2 lifts of 2" HMA (whichever is greater).
6. Paving is subject to WSDOT compaction & flatness requirements.
7. Pavement to be replaced on this date TBD as directed by and to the satisfaction of the City Engineering Department.
8. Backfill of trenches shall be in accordance with the City of Burlington's 'Typical Trench Detail' drawing unless approved otherwise by the City Engineer. Backfilled trenches awaiting an approved permanent wearing course shall be maintained in a smooth condition with 4 inches of pre-mixed material (cold-mix asphalt) at the surface.
9. I agree to maintain lights, signs, barricades and flagmen necessary for the protection of traffic at all times, day and night, during the work provided under this permit; and to comply with any instructions given by the City Engineering Department as to handling of traffic. Traffic shall be managed in accordance with the approved Traffic Control Plan if required as a condition of this permit.
10. I agree that no street or traffic lane may be closed to traffic unless approved by the City Engineer. \_\_\_\_\_ may be closed to traffic from \_\_\_\_\_ to \_\_\_\_\_.
11. All work must be completed by a licensed contractor.
12. City of Burlington standards for Trench Detail and ROW Work Requirements, attached.

I agree to comply with all of the conditions, restrictions and regulations of the City of Burlington and to guarantee such construction for not less than two years.

I declare under penalty of perjury under the laws of the State of Washington that all of the statements and answers contained in the materials provided to the City allowing this permit to be issued, is in all respects true, correct, and complete to the best of my knowledge and belief. By affixing my signature below, I certify that I am the owner, or am acting as the Owner's authorized agent and I will ensure all provisions of laws and ordinances governing the type of work this permit includes will be complied with whether specified herein or not, including calls for inspections.

When signed and dated below, this is your permit. Permission is hereby given to do the above-described work, according to the conditions hereon and according to the approved plans and specifications pertaining thereto, subject to compliance with the ordinances of the City of Burlington.

BY SIGNING BELOW I HEREBY ACKNOWLEDGE THAT I HAVE READ THIS DOCUMENT, UNDERSTAND ITS CONTENTS AND AGREE TO BE BOUND BY ITS TERMS.

Signature of Owner: emailed to applicant, Date: 07/26/2024, Public Works Official Signature: kjo for Brian Dempsey, Date: 07/26/2024



## **City of Burlington – Rules & Requirements for R.O.W. Work:**

All work in the Right of Way must be done by a licensed contractor with a current City of Burlington Business License. This work will require a Right of Way permit to be approved by the City of Burlington.

Right of Way permits are limited to the scope of work consisting of; 6 neighboring homes or 2 neighboring commercial businesses. Anything beyond that scope will require additional permits.

Private property is NOT to be accessed under any circumstance, unless permission is granted by the property owner.

No parking of vehicles or equipment on the sidewalks.

Proper pedestrian detour signs need to be utilized when a sidewalk is closed or under repair.

All fiber boring and conduits must be at a 24” minimum depth.

Working hours are 7:00 am – 10:00 pm Monday thru Friday and 8:00 am to 6:00 pm on weekends.

Temporary patching needs to be done in a manner that doesn't produce previously non-existing contour to the roadway and or sidewalk. This means that the material needs to be properly graded and compacted, no dips or bumps.

Any surface disturbance, concrete, asphalt, soil, etc. must be fully restored within 2 weeks of initial disturbance.

Any and all work, must follow the City of Burlington Specification Sheets provided with the approved Right of Way permit.

Ryan Spurrier  
City of Burlington – Public Works / Engineering  
Desk: 360-755-9715  
Cell: 360-399-0558  
Email: ryans@burlingtonwa.gov

# UTILITY TRENCHING - SUBGRADE AND TOP COURSE - STREET CUTS:

1. CLASS 1/2-INCH HMA PAVEMENT COMPACTED TO 92% MAX DENSITY. TWO 2" LIFTS, OR MATCH DEPTH TO EXISTING.
2. COMPACTED DEPTH OF CRUSHED SURFACING 2" TOP COURSE & 2" BASE COURSE MATERIAL TO BE COMPACTED TO 95% MAX DENSITY, REFER TO ASPHALT SECTIONS.
3. GRAVEL BORROW COMPACTED TO 95% OF MAX DENSITY. LOOSE LIFT THICKNESS SHALL NOT EXCEED 8" IN DEPTH.
4. 8" DEPTH OF BEDDING MATERIAL AS SPECIFIED TO BE HAND COMPACTED ABOVE CROWN OF PIPE. PEA GRAVEL AND BUCKSHOT NOT ALLOWED IN WATERLINE TRENCHES. WATERLINE SHALL BE COVERED AS NOTED ON PUD WATER NOTES. PEA GRAVEL OR BUCKSHOT TO BE USED IN SANITARY SEWER TRENCHES.
5. HAND COMPACTED BEDDING MATERIAL AS SPECIFIED TO BE TAMPED AROUND THE PIPE. THICKNESS = OUTSIDE DIAMETER OF PIPE.
6. 6" DEPTH OF BEDDING MATERIAL AS SPECIFIED BACKFILL TO BE HAND COMPACTED. PEA GRAVEL AND BUCKSHOT NOT ALLOWED IN WATER LINE TRENCHES. WATERLINE TRENCHES SHALL BE COVERED AS NOTED ON PUD WATER NOTES. PEA GRAVEL OR BUCKSHOT TO BE USED IN SANITARY SEWER TRENCHES.
7. EXISTING ASPHALT.
8. TACK ALL EDGES AND FACES OF EXISTING ASPHALT. SEAL SURFACE JOINT AS SPECIFIED.
9. 6" DISTANCE MINIMUM FOR UTILITIES INSTALLED WITHIN THE LIMITS OF EXISTING ASPHALT.
10. TRENCH LINE.
11. UNDISTURBED EARTH.
12. TRACER TAPE PLACED 12"-18" BELOW FINISHED GRADE, AND PER WSDOT STD SEC 9-15.18
13. 2" PVC SPARE CONDUIT, 24" BELOW TOP OF ASPHALT.

ALL UTILITY TRENCHES FOR POWER, GAS, TELEPHONE, TELEVISION CABLE, FIBER OPTIC, WATER LINES, SANITARY SEWER AND STORM DRAINS SHALL BE EXCAVATED TO ALLOW A MINIMUM OF 8" BETWEEN THE EDGE OF THE UTILITY AND THE TRENCH WALL. TRENCHES SHALL BE EXCAVATED TO THE DEPTH AS REQUIRED FOR GRAVITY UTILITIES AND SHALL BE EXCAVATED TO ALLOW A MINIMUM OF 36" OF COVER OVER TOP OF PROPOSED WATER LINES TO FINISH GRADE UNLESS OTHERWISE REQUIRED. THE DEPTH OF THE UTILITY TRENCHES FOR POWER, TELEPHONE, TELEVISION CABLE, FIBER OPTIC AND GAS, SHALL CONFORM TO THE REQUIREMENTS OF THE SPECIFIC UTILITY COMPANY. THE CONTRACTOR SHALL COORDINATE ALL SITE REQUIREMENTS AND SCHEDULING WITH THE NECESSARY UTILITY COMPANIES.

ALL SUBGRADE CONDITIONS SHALL BE PREPARED AND COMPACTED CONFORMING TO WSDOT SECTION 2-06.3 (1) AND 2-06.3 (2). THE SUBGRADE CONDITIONS SHALL BE COMPACTED TO A MINIMUM OF 95% MAXIMUM DRY DENSITY WITH A MOISTURE CONTENT OF +/- 2% FROM OPTIMUM. THE CONTRACTOR SHALL PERFORM ALL WORK NECESSARY TO ACHIEVE THE REQUIRED SUBGRADE CONDITIONS, INCLUDING PROTECTING THE SUBGRADE FROM EXCESSIVE MOISTURE AND CONDITIONING THE NATIVE SUBGRADE TO REMOVE MOISTURE.

THE CONTRACTOR MUST HAVE ALL SUBGRADES, AT THE BOTTOM OF GRAVEL AND CRUSHED ROCK, INSPECTED AND TESTED BY A SOILS ENGINEER AND INSPECTED BY THE CITY OF BURLINGTON PRIOR TO HOT MIX ASPHALT PATCHING OR POURING OF NEW CONCRETE. HMA COMPACTION TESTING FOR 92% RICE DENSITY.

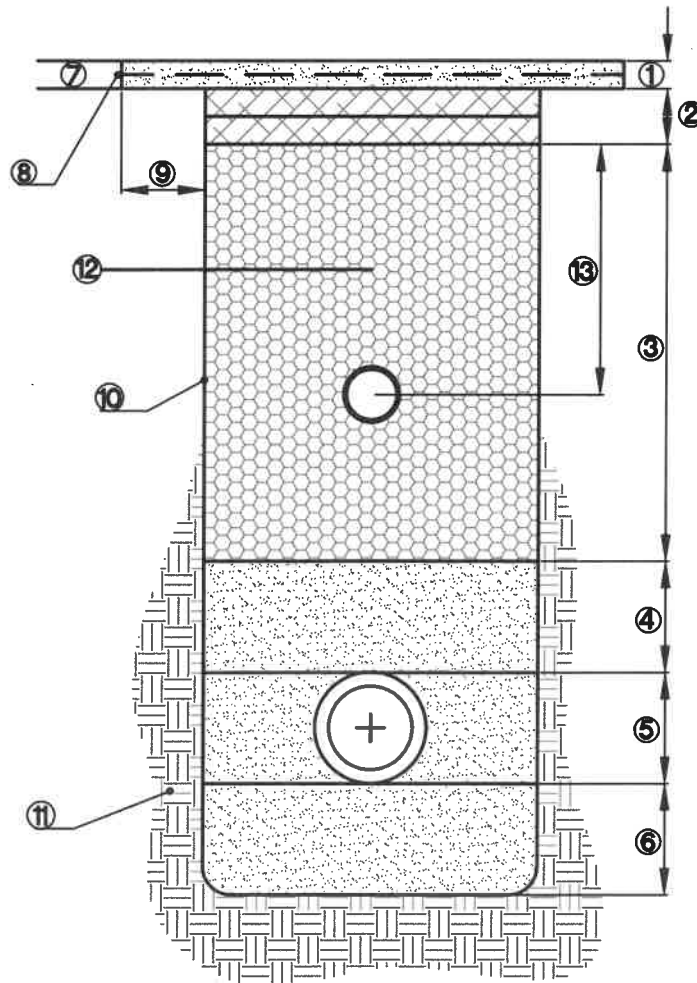

## CITY OF BURLINGTON - TRENCHING DETAIL

SCALE: N/A

MAP USAGE WARNING  
This map was produced with the intention of giving the user a general understanding of the geography in this area. This map was not intended to be used for purposes which require precise measurements.



**PUBLIC WORKS**  
833 S. Spruce Street  
Burlington, WA 98233  
(360) 755-9715 -- Office

# RIGHT OF WAY

ISSUE DATE: 07/26/2024

**Permit Number: ROW24-0037**

**APPLICANT:** SKAGIT COUNTY PUD  
1415 FREEWAY DR  
MOUNT VERNON, WA 98273  
360-391-9282

**PRIMARY CONTRACTOR NAME A...**

**THIS PERMIT AUTHORIZES THE BELOW DESCRIBED WORK:**

ROW - PUD replacement of approximately 940 lf of 4-inch AC with 8-inch Ductile Iron Water Main

**CONDITIONS AND COMMENTS APPLICABLE TO THIS PERMIT:**

**SCOPE OF WORK - #2 of 4 project areas for PUD water main replacement: S Alder Str: E Sharon to Orange Ave**

1. Work to begin in late summer/early fall 2024.
2. Provide 2 week notice in advance of construction to all property owners in proximity of work.
3. No open-cutting of street is permitted for the lateral lines (services to homes)
4. Any castings/iron that needs adjustment shall follow WSDOT specification 5-04 for flatness.
5. For surface restoration, match existing asphalt thickness or provide 2 lifts of 2" HMA (whichever is greater).
6. Paving is subject to WSDOT compaction & flatness requirements.
7. Pavement to be replaced on this date **TBD** as directed by and to the satisfaction of the City Engineering Department.
8. Backfill of trenches shall be in accordance with the City of Burlington's "Typical Trench Detail" drawing unless approved otherwise by the City Engineer. Backfilled trenches awaiting an approved permanent wearing course shall be maintained in a smooth condition with 4 inches of pre-mixed material (cold-mix asphalt) at the surface.
9. I agree to maintain lights, signs, barricades and flagmen necessary for the protection of traffic at all times, day and night, during the work provided under this permit; and to comply with any instructions given by the City Engineering Department as to handling of traffic. Traffic shall be managed in accordance with the approved Traffic Control Plan if required as a condition of this permit.
10. I agree that no street or traffic lane may be closed to traffic unless approved by the City Engineer. \_\_\_\_\_ may be closed to traffic from \_\_\_\_\_ to \_\_\_\_\_
11. All work must be completed by a licensed contractor.
12. City of Burlington standards for Trench Detail and ROW Work Requirements, attached.

I agree to comply with all of the conditions, restrictions and regulations of the City of Burlington and to guarantee such construction for not less than two years.

I declare under penalty of perjury under the laws of the State of Washington that all of the statements and answers contained in the materials provided to the City allowing this permit to be issued, is in all respects true, correct, and complete to the best of my knowledge and belief. By affixing my signature below, I certify that I am the owner, or am acting as the Owner's authorized agent and I will ensure all provisions of laws and ordinances governing the type of work this permit includes will be complied with whether specified herein or not, including calls for inspections.

When signed and dated below, this is your permit. Permission is hereby given to do the above-described work, according to the conditions hereon and according to the approved plans and specifications pertaining thereto, subject to compliance with the ordinances of the City of Burlington.

**BY SIGNING BELOW I HEREBY ACKNOWLEDGE THAT I HAVE READ THIS DOCUMENT, UNDERSTAND ITS CONTENTS AND AGREE TO BE BOUND BY ITS TERMS.**

emailed to applicant	07/26/2024	kjo for Brian Dempsey	07/26/2024
Signature of Owner	Date	Public Works Official Signature	Date



## **City of Burlington – Rules & Requirements for R.O.W. Work:**

All work in the Right of Way must be done by a licensed contractor with a current City of Burlington Business License. This work will require a Right of Way permit to be approved by the City of Burlington.

Right of Way permits are limited to the scope of work consisting of; 6 neighboring homes or 2 neighboring commercial businesses. Anything beyond that scope will require additional permits.

Private property is NOT to be accessed under any circumstance, unless permission is granted by the property owner.

No parking of vehicles or equipment on the sidewalks.

Proper pedestrian detour signs need to be utilized when a sidewalk is closed or under repair.

All fiber boring and conduits must be at a 24” minimum depth.

Working hours are 7:00 am – 10:00 pm Monday thru Friday and 8:00 am to 6:00 pm on weekends.

Temporary patching needs to be done in a manner that doesn't produce previously non-existing contour to the roadway and or sidewalk. This means that the material needs to be properly graded and compacted, no dips or bumps.

Any surface disturbance, concrete, asphalt, soil, etc. must be fully restored within 2 weeks of initial disturbance.

Any and all work, must follow the City of Burlington Specification Sheets provided with the approved Right of Way permit.

Ryan Spurrier  
City of Burlington – Public Works / Engineering  
Desk: 360-755-9715  
Cell: 360-399-0558  
Email: ryans@burlingtonwa.gov

# UTILITY TRENCHING - SUBGRADE AND TOP COURSE - STREET CUTS:

1. CLASS 1/2-INCH HMA PAVEMENT COMPACTED TO 92% MAX DENSITY. TWO 2" LIFTS, OR MATCH DEPTH TO EXISTING.
2. COMPACTED DEPTH OF CRUSHED SURFACING 2" TOP COURSE & 2" BASE COURSE MATERIAL TO BE COMPACTED TO 95% MAX DENSITY, REFER TO ASPHALT SECTIONS.
3. GRAVEL BORROW COMPACTED TO 95% OF MAX DENSITY. LOOSE LIFT THICKNESS SHALL NOT EXCEED 8" IN DEPTH.
4. 8" DEPTH OF BEDDING MATERIAL AS SPECIFIED TO BE HAND COMPACTED ABOVE CROWN OF PIPE. PEA GRAVEL AND BUCKSHOT NOT ALLOWED IN WATERLINE TRENCHES. WATERLINE SHALL BE COVERED AS NOTED ON PUD WATER NOTES. PEA GRAVEL OR BUCKSHOT TO BE USED IN SANITARY SEWER TRENCHES.
5. HAND COMPACTED BEDDING MATERIAL AS SPECIFIED TO BE TAMPED AROUND THE PIPE. THICKNESS = OUTSIDE DIAMETER OF PIPE.
6. 6" DEPTH OF BEDDING MATERIAL AS SPECIFIED BACKFILL TO BE HAND COMPACTED. PEA GRAVEL AND BUCKSHOT NOT ALLOWED IN WATER LINE TRENCHES. WATERLINE TRENCHES SHALL BE COVERED AS NOTED ON PUD WATER NOTES. PEA GRAVEL OR BUCKSHOT TO BE USED IN SANITARY SEWER TRENCHES.
7. EXISTING ASPHALT.
8. TACK ALL EDGES AND FACES OF EXISTING ASPHALT. SEAL SURFACE JOINT AS SPECIFIED.
9. 6" DISTANCE MINIMUM FOR UTILITIES INSTALLED WITHIN THE LIMITS OF EXISTING ASPHALT.
10. TRENCH LINE.
11. UNDISTURBED EARTH.
12. TRACER TAPE PLACED 12"-18" BELOW FINISHED GRADE, AND PER WSDOT STD SEC 9-15.18
13. 2" PVC SPARE CONDUIT, 24" BELOW TOP OF ASPHALT.

ALL UTILITY TRENCHES FOR POWER, GAS, TELEPHONE, TELEVISION CABLE, FIBER OPTIC, WATER LINES, SANITARY SEWER AND STORM DRAINS SHALL BE EXCAVATED TO ALLOW A MINIMUM OF 8" BETWEEN THE EDGE OF THE UTILITY AND THE TRENCH WALL. TRENCHES SHALL BE EXCAVATED TO THE DEPTH AS REQUIRED FOR GRAVITY UTILITIES AND SHALL BE EXCAVATED TO ALLOW A MINIMUM OF 36" OF COVER OVER TOP OF PROPOSED WATER LINES TO FINISH GRADE UNLESS OTHERWISE REQUIRED. THE DEPTH OF THE UTILITY TRENCHES FOR POWER, TELEPHONE, TELEVISION CABLE, FIBER OPTIC AND GAS, SHALL CONFORM TO THE REQUIREMENTS OF THE SPECIFIC UTILITY COMPANY. THE CONTRACTOR SHALL COORDINATE ALL SITE REQUIREMENTS AND SCHEDULING WITH THE NECESSARY UTILITY COMPANIES.

ALL SUBGRADE CONDITIONS SHALL BE PREPARED AND COMPACTED CONFORMING TO WSDOT SECTION 2-06.3 (1) AND 2-06.3 (2). THE SUBGRADE CONDITIONS SHALL BE COMPACTED TO A MINIMUM OF 95% MAXIMUM DRY DENSITY WITH A MOISTURE CONTENT OF +/- 2% FROM OPTIMUM. THE CONTRACTOR SHALL PERFORM ALL WORK NECESSARY TO ACHIEVE THE REQUIRED SUBGRADE CONDITIONS, INCLUDING PROTECTING THE SUBGRADE FROM EXCESSIVE MOISTURE AND CONDITIONING THE NATIVE SUBGRADE TO REMOVE MOISTURE.

THE CONTRACTOR MUST HAVE ALL SUBGRADES, AT THE BOTTOM OF GRAVEL AND CRUSHED ROCK, INSPECTED AND TESTED BY A SOILS ENGINEER AND INSPECTED BY THE CITY OF BURLINGTON PRIOR TO HOT MIX ASPHALT PATCHING OR POURING OF NEW CONCRETE. HMA COMPACTION TESTING FOR 92% RICE DENSITY.

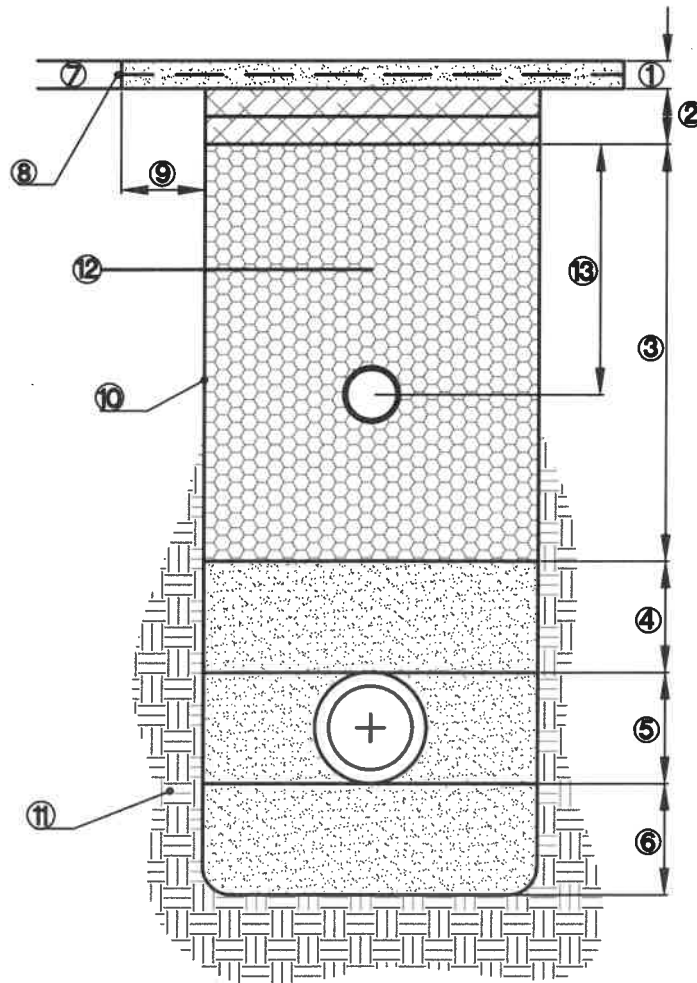

CITY OF BURLINGTON - TRENCHING DETAIL

SCALE: N/A

MAP USAGE WARNING  
This map was produced with the intention of giving the user a general understanding of the geography in this area. This map was not intended to be used for purposes which require precise measurements.



**PUBLIC WORKS**  
833 S. Spruce Street  
Burlington, WA 98233  
(360) 755-9715 -- Office

# RIGHT OF WAY

ISSUE DATE: 07/26/2024

**Permit Number: ROW24-0038**

**APPLICANT:** SKAGIT COUNTY PUD  
1415 FREEWAY DR  
MOUNT VERNON, WA 98273  
360-391-9282

**PRIMARY CONTRACTOR NAME A...**

**THIS PERMIT AUTHORIZES THE BELOW DESCRIBED WORK:**

ROW - PUD replacement of approximately 660 lf of 6-inch AC/PVC with 8-inch Ductile Iron Water Main

**CONDITIONS AND COMMENTS APPLICABLE TO THIS PERMIT:**

**SCOPE OF WORK - #3 of 4 project areas for PUD water main replacement:**

**S Walnut Str: Hazel to Avon Ave; Avon Ave: S Walnut to N Spruce Str.**

1. Work to begin in late summer/early fall 2024.
2. Provide 2 week notice in advance of construction to all property owners in proximity of work.
3. No open-cutting of street is permitted for the lateral lines (services to homes)
4. Any castings/iron that needs adjustment shall follow WSDOT specification 5-04 for flatness.
5. For surface restoration, match existing asphalt thickness or provide 2 lifts of 2" HMA (whichever is greater).
6. Paving is subject to WSDOT compaction & flatness requirements.
7. Pavement to be replaced on this date **TBD** as directed by and to the satisfaction of the City Engineering Department.
8. Backfill of trenches shall be in accordance with the City of Burlington's "Typical Trench Detail" drawing unless approved otherwise by the City Engineer. Backfilled trenches awaiting an approved permanent wearing course shall be maintained in a smooth condition with 4 inches of pre-mixed material (cold-mix asphalt) at the surface.
9. I agree to maintain lights, signs, barricades and flagmen necessary for the protection of traffic at all times, day and night, during the work provided under this permit; and to comply with any instructions given by the City Engineering Department as to handling of traffic. Traffic shall be managed in accordance with the approved Traffic Control Plan if required as a condition of this permit.
10. I agree that no street or traffic lane may be closed to traffic unless approved by the City Engineer. \_\_\_\_\_ may be closed to traffic from \_\_\_\_\_ to \_\_\_\_\_
11. All work must be completed by a licensed contractor.
12. City of Burlington standards for Trench Detail and ROW Work Requirements, attached.

I agree to comply with all of the conditions, restrictions and regulations of the City of Burlington and to guarantee such construction for not less than two years.

I declare under penalty of perjury under the laws of the State of Washington that all of the statements and answers contained in the materials provided to the City allowing this permit to be issued, is in all respects true, correct, and complete to the best of my knowledge and belief. By affixing my signature below, I certify that I am the owner, or am acting as the Owner's authorized agent and I will ensure all provisions of laws and ordinances governing the type of work this permit includes will be complied with whether specified herein or not, including calls for inspections.

When signed and dated below, this is your permit. Permission is hereby given to do the above-described work, according to the conditions hereon and according to the approved plans and specifications pertaining thereto, subject to compliance with the ordinances of the City of Burlington.

**BY SIGNING BELOW I HEREBY ACKNOWLEDGE THAT I HAVE READ THIS DOCUMENT, UNDERSTAND ITS CONTENTS AND AGREE TO BE BOUND BY ITS TERMS.**

emailed to applicant	07/26/2024	kjo for Brian Dempsey	07/26/2024
Signature of Owner	Date	Public Works Official Signature	Date





## **City of Burlington – Rules & Requirements for R.O.W. Work:**

All work in the Right of Way must be done by a licensed contractor with a current City of Burlington Business License. This work will require a Right of Way permit to be approved by the City of Burlington.

Right of Way permits are limited to the scope of work consisting of; 6 neighboring homes or 2 neighboring commercial businesses. Anything beyond that scope will require additional permits.

Private property is NOT to be accessed under any circumstance, unless permission is granted by the property owner.

No parking of vehicles or equipment on the sidewalks.

Proper pedestrian detour signs need to be utilized when a sidewalk is closed or under repair.

All fiber boring and conduits must be at a 24” minimum depth.

Working hours are 7:00 am – 10:00 pm Monday thru Friday and 8:00 am to 6:00 pm on weekends.

Temporary patching needs to be done in a manner that doesn't produce previously non-existing contour to the roadway and or sidewalk. This means that the material needs to be properly graded and compacted, no dips or bumps.

Any surface disturbance, concrete, asphalt, soil, etc. must be fully restored within 2 weeks of initial disturbance.

Any and all work, must follow the City of Burlington Specification Sheets provided with the approved Right of Way permit.

Ryan Spurrier  
City of Burlington – Public Works / Engineering  
Desk: 360-755-9715  
Cell: 360-399-0558  
Email: ryans@burlingtonwa.gov



# UTILITY TRENCHING - SUBGRADE AND TOP COURSE - STREET CUTS:

1. CLASS 1/2-INCH HMA PAVEMENT COMPACTED TO 92% MAX DENSITY. TWO 2" LIFTS, OR MATCH DEPTH TO EXISTING.
2. COMPACTED DEPTH OF CRUSHED SURFACING 2" TOP COURSE & 2" BASE COURSE MATERIAL TO BE COMPACTED TO 95% MAX DENSITY, REFER TO ASPHALT SECTIONS.
3. GRAVEL BORROW COMPACTED TO 95% OF MAX DENSITY. LOOSE LIFT THICKNESS SHALL NOT EXCEED 8" IN DEPTH.
4. 8" DEPTH OF BEDDING MATERIAL AS SPECIFIED TO BE HAND COMPACTED ABOVE CROWN OF PIPE. PEA GRAVEL AND BUCKSHOT NOT ALLOWED IN WATERLINE TRENCHES. WATERLINE SHALL BE COVERED AS NOTED ON PUD WATER NOTES. PEA GRAVEL OR BUCKSHOT TO BE USED IN SANITARY SEWER TRENCHES.
5. HAND COMPACTED BEDDING MATERIAL AS SPECIFIED TO BE TAMPED AROUND THE PIPE. THICKNESS = OUTSIDE DIAMETER OF PIPE.
6. 6" DEPTH OF BEDDING MATERIAL AS SPECIFIED BACKFILL TO BE HAND COMPACTED. PEA GRAVEL AND BUCKSHOT NOT ALLOWED IN WATER LINE TRENCHES. WATERLINE TRENCHES SHALL BE COVERED AS NOTED ON PUD WATER NOTES. PEA GRAVEL OR BUCKSHOT TO BE USED IN SANITARY SEWER TRENCHES.
7. EXISTING ASPHALT.
8. TACK ALL EDGES AND FACES OF EXISTING ASPHALT. SEAL SURFACE JOINT AS SPECIFIED.
9. 6" DISTANCE MINIMUM FOR UTILITIES INSTALLED WITHIN THE LIMITS OF EXISTING ASPHALT.
10. TRENCH LINE.
11. UNDISTURBED EARTH.
12. TRACER TAPE PLACED 12"-18" BELOW FINISHED GRADE, AND PER WSDOT STD SEC 9-15.18
13. 2" PVC SPARE CONDUIT, 24" BELOW TOP OF ASPHALT.

ALL UTILITY TRENCHES FOR POWER, GAS, TELEPHONE, TELEVISION CABLE, FIBER OPTIC, WATER LINES, SANITARY SEWER AND STORM DRAINS SHALL BE EXCAVATED TO ALLOW A MINIMUM OF 8" BETWEEN THE EDGE OF THE UTILITY AND THE TRENCH WALL. TRENCHES SHALL BE EXCAVATED TO THE DEPTH AS REQUIRED FOR GRAVITY UTILITIES AND SHALL BE EXCAVATED TO ALLOW A MINIMUM OF 36" OF COVER OVER TOP OF PROPOSED WATER LINES TO FINISH GRADE UNLESS OTHERWISE REQUIRED. THE DEPTH OF THE UTILITY TRENCHES FOR POWER, TELEPHONE, TELEVISION CABLE, FIBER OPTIC AND GAS, SHALL CONFORM TO THE REQUIREMENTS OF THE SPECIFIC UTILITY COMPANY. THE CONTRACTOR SHALL COORDINATE ALL SITE REQUIREMENTS AND SCHEDULING WITH THE NECESSARY UTILITY COMPANIES.

ALL SUBGRADE CONDITIONS SHALL BE PREPARED AND COMPACTED CONFORMING TO WSDOT SECTION 2-06.3 (1) AND 2-06.3 (2). THE SUBGRADE CONDITIONS SHALL BE COMPACTED TO A MINIMUM OF 95% MAXIMUM DRY DENSITY WITH A MOISTURE CONTENT OF +/- 2% FROM OPTIMUM. THE CONTRACTOR SHALL PERFORM ALL WORK NECESSARY TO ACHIEVE THE REQUIRED SUBGRADE CONDITIONS, INCLUDING PROTECTING THE SUBGRADE FROM EXCESSIVE MOISTURE AND CONDITIONING THE NATIVE SUBGRADE TO REMOVE MOISTURE.

THE CONTRACTOR MUST HAVE ALL SUBGRADES, AT THE BOTTOM OF GRAVEL AND CRUSHED ROCK, INSPECTED AND TESTED BY A SOILS ENGINEER AND INSPECTED BY THE CITY OF BURLINGTON PRIOR TO HOT MIX ASPHALT PATCHING OR POURING OF NEW CONCRETE. HMA COMPACTION TESTING FOR 92% RICE DENSITY.

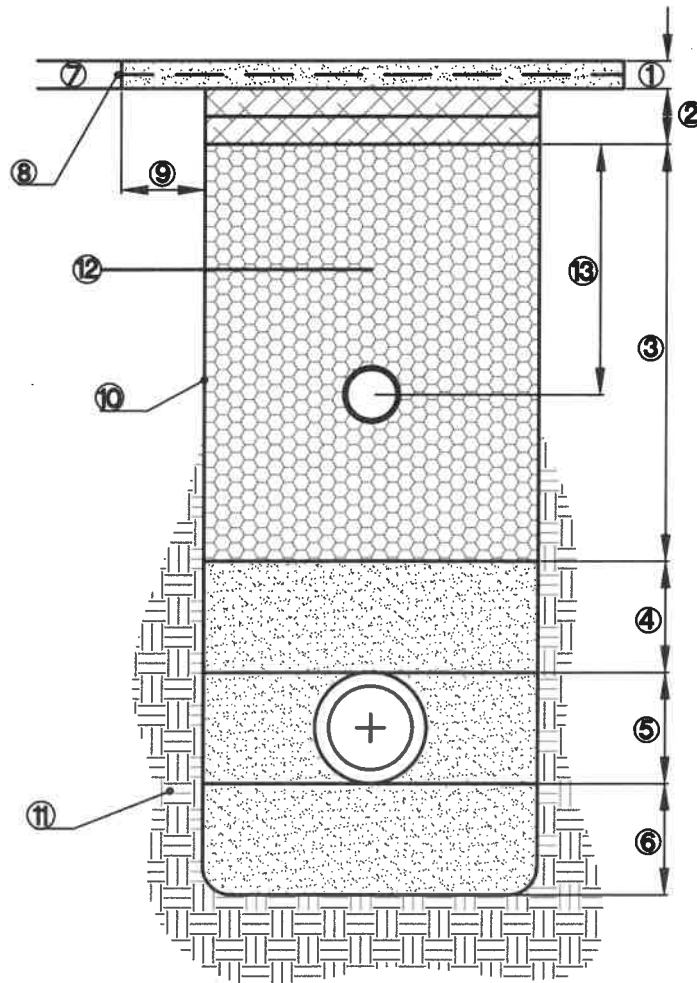

CITY OF BURLINGTON - TRENCHING DETAIL

SCALE: N/A

MAP USAGE WARNING  
This map was produced with the intention of giving the user a general understanding of the geography in this area. This map was not intended to be used for purposes which require precise measurements.



**PUBLIC WORKS**  
833 S. Spruce Street  
Burlington, WA 98233  
(360) 755-9715 -- Office

# RIGHT OF WAY

ISSUE DATE: 07/26/2024

**Permit Number: ROW24-0039**

**APPLICANT:** SKAGIT COUNTY PUD  
1415 FREEWAY DR  
MOUNT VERNON, WA 98273  
360-391-9282

**PRIMARY CONTRACTOR NAME A...**

**THIS PERMIT AUTHORIZES THE BELOW DESCRIBED WORK:**

ROW - Replacement of approximately 1,350 LF of 4-inch AC with 8-inch Ductile Iron Water Main

**CONDITIONS AND COMMENTS APPLICABLE TO THIS PERMIT:**

**SCOPE OF WORK - #4 of 4 project areas for PUD water main replacement: S Walnut Str: Washington Ave to E Victoria Ave.**

1. Work to begin in late summer/early fall 2024.
2. Provide 2 week notice in advance of construction to all property owners in proximity of work.
3. No open-cutting of street is permitted for the lateral lines (services to homes)
4. Any castings/iron that needs adjustment shall follow WSDOT specification 5-04 for flatness.
5. For surface restoration, match existing asphalt thickness or provide 2 lifts of 2" HMA (whichever is greater).
6. Paving is subject to WSDOT compaction & flatness requirements.
7. Pavement to be replaced on this date **TBD** as directed by and to the satisfaction of the City Engineering Department.
8. Backfill of trenches shall be in accordance with the City of Burlington's "Typical Trench Detail" drawing unless approved otherwise by the City Engineer. Backfilled trenches awaiting an approved permanent wearing course shall be maintained in a smooth condition with 4 inches of pre-mixed material (cold-mix asphalt) at the surface.
9. I agree to maintain lights, signs, barricades and flagmen necessary for the protection of traffic at all times, day and night, during the work provided under this permit; and to comply with any instructions given by the City Engineering Department as to handling of traffic. Traffic shall be managed in accordance with the approved Traffic Control Plan if required as a condition of this permit.
10. I agree that no street or traffic lane may be closed to traffic unless approved by the City Engineer. \_\_\_\_\_ may be closed to traffic from \_\_\_\_\_ to \_\_\_\_\_
11. All work must be completed by a licensed contractor.
12. City of Burlington standards for Trench Detail and ROW Work Requirements, attached.

I agree to comply with all of the conditions, restrictions and regulations of the City of Burlington and to guarantee such construction for not less than two years.

I declare under penalty of perjury under the laws of the State of Washington that all of the statements and answers contained in the materials provided to the City allowing this permit to be issued, is in all respects true, correct, and complete to the best of my knowledge and belief. By affixing my signature below, I certify that I am the owner, or am acting as the Owner's authorized agent and I will ensure all provisions of laws and ordinances governing the type of work this permit includes will be complied with whether specified herein or not, including calls for inspections.

When signed and dated below, this is your permit. Permission is hereby given to do the above-described work, according to the conditions hereon and according to the approved plans and specifications pertaining thereto, subject to compliance with the ordinances of the City of Burlington.

**BY SIGNING BELOW I HEREBY ACKNOWLEDGE THAT I HAVE READ THIS DOCUMENT, UNDERSTAND ITS CONTENTS AND AGREE TO BE BOUND BY ITS TERMS.**

emailed to applicant	07/26/2024	kjo for Brian Dempsey	07/26/2024
Signature of Owner	Date	Public Works Official Signature	Date



## **City of Burlington – Rules & Requirements for R.O.W. Work:**

All work in the Right of Way must be done by a licensed contractor with a current City of Burlington Business License. This work will require a Right of Way permit to be approved by the City of Burlington.

Right of Way permits are limited to the scope of work consisting of; 6 neighboring homes or 2 neighboring commercial businesses. Anything beyond that scope will require additional permits.

Private property is NOT to be accessed under any circumstance, unless permission is granted by the property owner.

No parking of vehicles or equipment on the sidewalks.

Proper pedestrian detour signs need to be utilized when a sidewalk is closed or under repair.

All fiber boring and conduits must be at a 24” minimum depth.

Working hours are 7:00 am – 10:00 pm Monday thru Friday and 8:00 am to 6:00 pm on weekends.

Temporary patching needs to be done in a manner that doesn't produce previously non-existing contour to the roadway and or sidewalk. This means that the material needs to be properly graded and compacted, no dips or bumps.

Any surface disturbance, concrete, asphalt, soil, etc. must be fully restored within 2 weeks of initial disturbance.

Any and all work, must follow the City of Burlington Specification Sheets provided with the approved Right of Way permit.

Ryan Spurrier  
City of Burlington – Public Works / Engineering  
Desk: 360-755-9715  
Cell: 360-399-0558  
Email: [ryans@burlingtonwa.gov](mailto:ryans@burlingtonwa.gov)

# UTILITY TRENCHING - SUBGRADE AND TOP COURSE - STREET CUTS:

1. CLASS 1/2-INCH HMA PAVEMENT COMPACTED TO 92% MAX DENSITY. TWO 2" LIFTS, OR MATCH DEPTH TO EXISTING.
2. COMPACTED DEPTH OF CRUSHED SURFACING 2" TOP COURSE & 2" BASE COURSE MATERIAL TO BE COMPACTED TO 95% MAX DENSITY, REFER TO ASPHALT SECTIONS.
3. GRAVEL BORROW COMPACTED TO 95% OF MAX DENSITY. LOOSE LIFT THICKNESS SHALL NOT EXCEED 8" IN DEPTH.
4. 8" DEPTH OF BEDDING MATERIAL AS SPECIFIED TO BE HAND COMPACTED ABOVE CROWN OF PIPE. PEA GRAVEL AND BUCKSHOT NOT ALLOWED IN WATERLINE TRENCHES. WATERLINE SHALL BE COVERED AS NOTED ON PUD WATER NOTES. PEA GRAVEL OR BUCKSHOT TO BE USED IN SANITARY SEWER TRENCHES.
5. HAND COMPACTED BEDDING MATERIAL AS SPECIFIED TO BE TAMPED AROUND THE PIPE. THICKNESS = OUTSIDE DIAMETER OF PIPE.
6. 6" DEPTH OF BEDDING MATERIAL AS SPECIFIED BACKFILL TO BE HAND COMPACTED. PEA GRAVEL AND BUCKSHOT NOT ALLOWED IN WATER LINE TRENCHES. WATERLINE TRENCHES SHALL BE COVERED AS NOTED ON PUD WATER NOTES. PEA GRAVEL OR BUCKSHOT TO BE USED IN SANITARY SEWER TRENCHES.
7. EXISTING ASPHALT.
8. TACK ALL EDGES AND FACES OF EXISTING ASPHALT. SEAL SURFACE JOINT AS SPECIFIED.
9. 6" DISTANCE MINIMUM FOR UTILITIES INSTALLED WITHIN THE LIMITS OF EXISTING ASPHALT.
10. TRENCH LINE.
11. UNDISTURBED EARTH.
12. TRACER TAPE PLACED 12"-18" BELOW FINISHED GRADE, AND PER WSDOT STD SEC 9-15.18
13. 2" PVC SPARE CONDUIT, 24" BELOW TOP OF ASPHALT.

ALL UTILITY TRENCHES FOR POWER, GAS, TELEPHONE, TELEVISION CABLE, FIBER OPTIC, WATER LINES, SANITARY SEWER AND STORM DRAINS SHALL BE EXCAVATED TO ALLOW A MINIMUM OF 8" BETWEEN THE EDGE OF THE UTILITY AND THE TRENCH WALL. TRENCHES SHALL BE EXCAVATED TO THE DEPTH AS REQUIRED FOR GRAVITY UTILITIES AND SHALL BE EXCAVATED TO ALLOW A MINIMUM OF 36" OF COVER OVER TOP OF PROPOSED WATER LINES TO FINISH GRADE UNLESS OTHERWISE REQUIRED. THE DEPTH OF THE UTILITY TRENCHES FOR POWER, TELEPHONE, TELEVISION CABLE, FIBER OPTIC AND GAS, SHALL CONFORM TO THE REQUIREMENTS OF THE SPECIFIC UTILITY COMPANY. THE CONTRACTOR SHALL COORDINATE ALL SITE REQUIREMENTS AND SCHEDULING WITH THE NECESSARY UTILITY COMPANIES.

ALL SUBGRADE CONDITIONS SHALL BE PREPARED AND COMPACTED CONFORMING TO WSDOT SECTION 2-06.3 (1) AND 2-06.3 (2). THE SUBGRADE CONDITIONS SHALL BE COMPACTED TO A MINIMUM OF 95% MAXIMUM DRY DENSITY WITH A MOISTURE CONTENT OF +/- 2% FROM OPTIMUM. THE CONTRACTOR SHALL PERFORM ALL WORK NECESSARY TO ACHIEVE THE REQUIRED SUBGRADE CONDITIONS, INCLUDING PROTECTING THE SUBGRADE FROM EXCESSIVE MOISTURE AND CONDITIONING THE NATIVE SUBGRADE TO REMOVE MOISTURE.

THE CONTRACTOR MUST HAVE ALL SUBGRADES, AT THE BOTTOM OF GRAVEL AND CRUSHED ROCK, INSPECTED AND TESTED BY A SOILS ENGINEER AND INSPECTED BY THE CITY OF BURLINGTON PRIOR TO HOT MIX ASPHALT PATCHING OR POURING OF NEW CONCRETE. HMA COMPACTION TESTING FOR 92% RICE DENSITY.

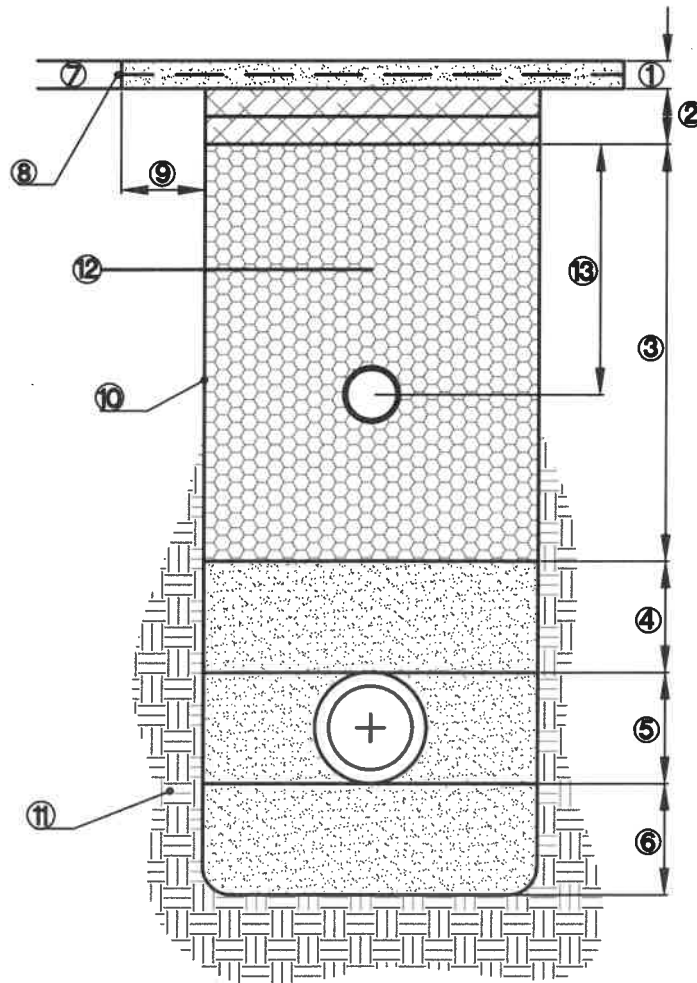

CITY OF BURLINGTON - TRENCHING DETAIL

SCALE: N/A

MAP USAGE WARNING  
This map was produced with the intention of giving the user a general understanding of the geography in this area. This map was not intended to be used for purposes which require precise measurements.

**APPENDIX C**  
**INADVERTENT DISCOVERY**  
**PLAN**



1415 Freeway Drive  
Mount Vernon, WA 98273-1436

tel: (360) 424-7104

www.SkagitPUD.org

*"Owned by the people we serve."*

## **Contractor Inadvertent Discovery Plan**

### **I. Protocol**

In the event that human remains and/or cultural or archaeological resources (see section II below) are encountered during the course of project construction, the following actions shall be taken:

- A. The contractor shall immediately stop work at and adjacent to the site of discovery, call back all haul trucks in transit containing loads of site soils, move any land-altering equipment to a reasonable distance from the discovery, completely secure the site, and contact Skagit PUD.
- B. If the discovery consists of cultural or archaeological items that do not include human remains, Skagit PUD shall notify the following parties:
  - 1) A professional archaeologist
  - 2) The Department of Archaeology and Historic Preservation (DAHP) (Rob Whitlam 360-890-2615)
  - 3) Swinomish Indian Tribal Community (Josephine Jefferson, 360-466-7352)
  - 4) Upper Skagit Tribe (Scott Schuyler, 360-982-8218)
  - 5) Samish Indian Nation (Jackie Ferry, 360-726-3399)
  - 6) Stillaguamish Tribe (Kerry Lyste, 360-657-3687 ext. 14)

If the discovery consists of human remains, the District shall immediately contact the following parties:

- 1) The Skagit County Sheriff's Department (non-emergency line: 360-416-1911) and the Skagit County Coroner, (Hayley L. Thompson 360-416-1996) to determine if the remains are forensic in nature.
  - 2) If the remains are not forensic in nature, Skagit PUD shall contact DAHP (Rob Whitlam 360-890-2615 and Lance Wollwage 360-890-2616); who will take the lead on determining the appropriate method of treatment for the remains and will consult with the affected tribes.
- C. Skagit PUD shall issue a written order to the contractor to cease all construction operations at the location of the potential cultural resources find. The order shall contain the following:

- 1) A clear description of the work to be suspended.
- 2) Any instructions regarding issuance of further orders by the contractor for material services.
- 3) Guidance as to action to be taken on the subcontracts.
- 4) Any suggestions to the contractor as to minimization of its costs.
- 5) Estimated duration of the temporary suspension.

The work suspension order shall be effective until such time as a qualified archaeologist can be called by Skagit PUD to assess the significance of the potential cultural resources and make recommendations to the State Historical Preservation Officer. If the archaeologist, in consultation with the State Historic Preservation Officer, determines that the potential find is a significant cultural resource, Skagit PUD shall extend the duration of the work suspension order, in writing, and the contractor shall suspend work at the location of the find.

## **II. Protected Cultural or Archaeological Resources**

Cultural material that may be protected by law could include but is not limited to:

- Buried layers of black soil with layers of shell, charcoal, and fish and/or mammal bones.
- Buried cobbles that may indicate a hearth feature;
- Non-natural sediment or stone deposits that may be related to activity areas of people;
- Stone, bone, shell, horn, or antler tools that may include projectile points, scrapers, cutting tools, wood working wedges or axes, and grinding stones;
- Stone tools or stone flakes;
- Perennially damp areas may have preservation conditions that allow for remnants of wood and other plant fibers; in these locations there may be remains including fragments of basketry, weaving, wood tools, or carved pieces; and
- Human remains.