



**SURVEY SYMBOLS**

SYMBOL	DESCRIPTION	BLOCK	LAYER
⊕	MONUMENT	SMON	SV-CTRL-EXST-SYM
⊕	MONUMENT IN CASE	SMIC	SV-CTRL-EXST-SYM
⊕	REBAR & CAP	RCS	SV-CTRL-EXST-SYM
△	SCRIBED "X"	SAP	SV-CTRL-EXST-SYM
X	PK NAIL	PK	SV-CTRL-EXST-SYM
B-101	SOIL BORING	BORE	SV-SOIL-EXST-SYM
TP-101	SOIL TEST PIT	TP	SV-SOIL-EXST-SYM
⊗	UTILITY POTHOLE/ GROUND WATER MONITORING WELL	P_SSB	UT-MISC-EXST-SYM

**SURFACE FEATURE SYMBOLS**

SYMBOL	DESCRIPTION	BLOCK	LAYER
⊔	METAL SIGN POST	E1S1	SF-SIGN-EXST-SYM
⊔	WOOD SIGN POST	SFSN	SF-SIGN-EXST-SYM
GTP ⊙	GATE POST	POST	SF-FENC-EXST-SYM
★	CONIFEROUS TREE	SFC	SF-VEGE-EXST-SYM
○	DECIDUOUS TREE	SFD	SF-VEGE-EXST-SYM
⊗	BUSH/SHRUB	PUDBUSH	SF-VEGE-EXST-SYM
⊙	STUMP	STUMP	SF-VEGE-EXST-SYM

**UTILITY SYMBOLS**

SYMBOL	DESCRIPTION	BLOCK	LAYER
⊙	SANITARY SEWER MANHOLE	PUDMH	SS-STCR-EXST-SYM
⊕	STORM DRAIN MANHOLE	SDMH	SD-STCR-EXST-SYM
□	CATCH BASIN	CBIN	SD-STCR-EXST-SYM
□	INLET/YARD DRAIN	SDGI	SD-STCR-EXST-SYM
⊕	GAS VALVE	GV	GS-VALV-EXST-SYM
⊕	GAS METER	P_GMET	GS-VALV-EXST-SYM
TR ⊗	TRAFFIC JUNCTION BOX	TJB1	TF-STCR-EXST-SYM
EL ⊗	ELEC. JUNCTION BOX	TJB1	PO-STCR-EXST-SYM
PM ⊗	POWER METER	EM	PO-STCR-EXST-SYM
TC ⊗	TELECOM. JUNCTION BOX	TJB1	TL-STCR-EXST-SYM
TV ⊗	CABLE TV JUNCTION BOX	TJB1	TV-STCR-EXST-SYM
⊗	JUNCTION BOX	TJB1	UT-STCR-EXST-SYM
T ⊕	TELEPHONE RISER	TEL R	TL-STCR-EXST-SYM
⊕	UTILITY POLE	UP	PO-STCR-EXST-SYM
UG ⊕	UTILITY POLE W/CONDUIT	UP	PO-STCR-EXST-SYM
⊕	GUY ANCHOR	UPA	PO-STCR-EXST-SYM
GP ⊕	GUY POLE	GUP	PO-STCR-EXST-SYM
⊕	TRANSFORMER	TRAN	PO-STCR-EXST-SYM
P ⊕	POWER VAULT	POWRV	PO-STCR-EXST-SYM
⊕	TRANSMISSION TOWER	PTWR	PO-STCR-EXST-SYM
T ⊕	TELEPHONE VAULT	TV	TL-STCR-EXST-SYM
→	PEDESTRIAN SIGNAL HEAD	TPSH	TF-SIGL-EXST-SYM
⊕	PEDESTRIAN SIGNAL BUTTON	TPB	TF-SIGL-EXST-SYM
⊕	TRAFFIC SIGNAL POLE W/LIGHT	TSPL	TF-SIGL-EXST-SYM
⊕	LUMINAIRE	TSLA	PO-STCR-EXST-SYM
⊕	YARD LIGHT	SFL	PO-STCR-EXST-SYM
⊕	MONITORING WELL	UT-STCR-EXST-SYM	UT-STCR-EXST-SYM
⊕	WATER MANHOLE	WMH	WA-STCR-EXST-SYM
SH ⊕	SPRINKLER HEAD	SPRHD	WA-MISC-EXST-SYM
IRBX ⊕	IRRIGATION BOX	ICV	WA-MISC-EXST-SYM

**WATER SYMBOLS**

SYMBOL	DESCRIPTION	BLOCK	LAYER
EXIST. ]	CAP/PLUG	X_CAP/P_CAP	WA-FITT-XXXX-SYM
PROG. #	COUPLING	X_COUP/P_COUP	WA-FITT-XXXX-SYM
=	SLEEVE	X_SLV/P_SLV	WA-FITT-XXXX-SYM
○	GUARD POST	X_GPOST/P_GPOST	WA-FITT-XXXX-SYM
▷	REDUCER	X_RED/P_RED	WA-FITT-XXXX-SYM
◁	THRUST BLOCK	X_TB/P_TB	WA-FITT-XXXX-SYM
⊕	WATER METER	X_MTR/P_MTR	WA-METR-XXXX-SYM
<b>FIRE HYDRANTS:</b>			
⊕	2 NOZZLE	X_HYD2/P_HYD2	WA-FHYD-XXXX-SYM
⊕	3 NOZZLE	X_HYD3/P_HYD3	WA-FHYD-XXXX-SYM
<b>JOINTS:</b>			
	FLANGE/BLIND FL	X_FL/P_FL	WA-FITT-XXXX-SYM
[	MECHANICAL	X_MJ/P_MJ	WA-FITT-XXXX-SYM
C	PUSH-ON/HUB	X_PHUB/P_PHUB	WA-FITT-XXXX-SYM
	THREAD	X_THREAD/P_THREAD	WA-FITT-XXXX-SYM
<b>VALVES</b>			
⊕	AIR RELIEF VALVE	X_AR/P_AR	WA-VALV-XXXX-SYM
⊕	BLOW-OFF VALVE	X_BO/P_BO	WA-VALV-XXXX-SYM
⊕	BUTTERFLY VALVE	X_BFV/P_BFV	WA-VALV-XXXX-SYM
⊕	CHECK VALVE	X_CV/P_CV	WA-VALV-XXXX-SYM
⊕	GATE VALVE	X_GV/P_GV	WA-VALV-XXXX-SYM
⊕	PLUG VALVE	X_PLUGV/P_PLUGV	WA-VALV-XXXX-SYM
<b>ELBOWS</b>			
⊕	90° ELBOW MjxMj		WA-FITT-XXXX-SYM
⊕	45° ELBOW MjxMj		WA-FITT-XXXX-SYM
⊕	22.5° ELBOW MjxMj		WA-FITT-XXXX-SYM
⊕	11.25° ELBOW MjxMj		WA-FITT-XXXX-SYM
⊕	CROSS MjxMj		WA-FITT-XXXX-SYM
⊕	TEE MjxMj		WA-FITT-XXXX-SYM
⊕	VERTICAL ELBOW MjxMj		WA-FITT-XXXX-SYM
⊕	45° ELBOW MjxFL		WA-FITT-XXXX-SYM
⊕	22.5° ELBOW MjxFL		WA-FITT-XXXX-SYM
⊕	11.25° ELBOW MjxFL		WA-FITT-XXXX-SYM
⊕	CROSS MjxFL		WA-FITT-XXXX-SYM
⊕	TEE MjxFL		WA-FITT-XXXX-SYM
⊕	CROSS FLxFL		WA-FITT-XXXX-SYM
⊕	TEE FLxFL		WA-FITT-XXXX-SYM
⊕	VERTICAL MjxFL		WA-FITT-XXXX-SYM
⊕	TAPPING SLEEVE		WA-FITT-XXXX-SYM

**NOTATION SYMBOLS**

SYMBOL	DESCRIPTION	BLOCK	LAYER
⊕	CATHODIC PROTECTION TEST STATION	CATH	G-ANNO-PROP-SYM
⊕	CHANGE IN PIPING MATERIAL	PMAT	G-ANNO-PROP-SYM
⊕	TRENCH BACKFILL AND SURFACE RESTORATION CODE	KEYNOTE	G-ANNO-PROP-SYM
⊕	CONSTRUCTION NOTE	KEYNOTES	G-ANNO-PROP-SYM

**TEXT**

DESCRIPTION	HEIGHT	LAYER
ROAD STATIONING	.10	SV-CNTL-EXST-TXT
PARCEL NUMBER	.20	SV-PRCL-EXST-TXT
ADDRESS	.15	G-MISC-EXST-TXT

**LINE TYPES**

LINETYPE	DESCRIPTION	LAYER
— GAS —	GENERIC GAS LINE	GS-PLIN-EXST-LIN
— GAS —	HIGH PRESSURE GAS	GS-PLIN-EXST-LIN
— GAS —	LOW PRESSURE GAS	GS-PLIN-EXST-LIN
— IRR —	IRRIGATION	WA-IRRI-EXST-LIN
— SD —	STORM DRAIN	SD-GLIN-EXST-LIN
=====	EXISTING CULVERT	SD-CULV-EXST-LIN
— SS —	SANITARY SEWER	SS-GLIN-EXST-LIN
— SS —	SS FORCEMAIN	SS-PLIN-EXST-LIN
— W — W —	WATER LINE	WA-PLIN-EXST-LIN
— UGE —	UNDERGROUND POWER	PO-BLIN-EXST-LIN
— UGF —	UNDERGROUND FIBER OPTIC	FO-BLIN-EXST-LIN
— UGT —	UNDERGROUND TELEPHONE	TL-BLIN-EXST-LIN
— UGTV —	UNDERGROUND TELEVISION	TV-BLIN-EXST-LIN
— OHE —	OVERHEAD ELECTRIC	PO-ALIN-EXST-LIN
— OHF —	OVERHEAD FIBER OPTIC	FO-ALIN-EXST-LIN
— OHF —	OVERHEAD TELEPHONE	TL-ALIN-EXST-LIN
— OHTV —	OVERHEAD TELEVISION	TV-ALIN-EXST-LIN
~~~~~	VEGETATION LINE	SF-VEGE-EXST-LIN
-----	EDGE OF GRAVEL	SF-GRVL-EXST-LIN
-----	EDGE OF ASPHALT	SF-ASPH-EXST-LIN
-----	CURB/CONCRETE LINE	SF-CONC-EXST-LIN
-----	DITCH FLOWLINE	SF-DTCH-EXST-LIN
— X — X —	EXISTING FENCE	SF-FENC-EXST-LIN
-----	TOP/TOE OF SLOPE	SF-GRAD-EXST-LIN
+++++	RAILROAD TRACKS	SF-RAIL-EXST-LIN
-----	CENTERLINE	SV-CNTL-EXST-LIN
-----	RIGHT OF WAY	SV-ROFW-EXST-LIN
-----	EASEMENT LINE	SV-ESMT-EXST-LIN
-----	PROPERTY LINE	SV-PROP-EXST-LIN
-----	PROPOSED WATERLINE	WA-PLIN-PROP-LIN
-----	PROPOSED METER LINE	WA-METR-PROP-LIN
-----	RECLAIMED WATER LINE	WA-RCW-EXST-LIN
-----	FOG LINE	SF-STRP-EXST-LIN
⚡	SHUTOFF DETAIL LINES	VARIABLES

**HATCHING**

DESCRIPTION	LAYER
ASPHALT - SOLID	SF-ASPH-EXST-HCH
GRAVEL - AR-SAND, 0', SCALE=1.6667	SF-FEAT-EXST-HCH
CONCRETE - AR-CONC, 0', SCALE=1.6667	SF-FEAT-EXST-HCH
WETLAND - GRASS, 0', SCALE=.10 OF DWG SCALE	SF-FEAT-EXST-HCH
<b>PAVEMENT RESTORATION:</b>	
TEMP PVMT. PATCH - DASH, 0', SCALE=0.30 OF DWG SCALE	SF-ASPH-PROP-HCH

ISSUE	REVISIONS	BY	DATE
1.	ISSUED FOR BIDDING	GJS	11/19/14
2.	ISSUED FOR BIDDING	MCH	7/21/22

**811**  
Know what's below.  
Call before you dig.

Professional Engineer  
7/21/2022

DATUM: HOR: ASSUMED VERT: NAVD 88	DSGN BY: MED DWN BY: MDO APPVD BY: MCH
DATE PRINTED: 7/28/22	SEC: 8 TWP: 34 N RGE: 2 E

**Skagit PUD**  
PUBLIC UTILITY DISTRICT  
1415 Freeway Drive  
Mount Vernon, WA 98273  
(360) 424-7104  
www.SkagitPud.org

SATTERLEE ROAD, GIBRALTER ROAD TO DRIVER ROAD  
PHASE I  
LEGEND  
SCALE: NONE  
P.N. 3505  
SHEET: 1 OF 11

## DISTRICT STANDARD GENERAL NOTES

(Minimum Requirements)

1. UNLESS STATED OTHERWISE, ALL WORK IS TO BE PERFORMED IN ACCORDANCE WITH THE MOST CURRENT WASHINGTON STATE DEPARTMENT OF TRANSPORTATION (WSDOT) STANDARD SPECIFICATIONS FOR ROAD, BRIDGE AND MUNICIPAL CONSTRUCTION AND THE DISTRICT REQUIREMENTS AS OUTLINED IN THE DISTRICT'S WATER POLICY MANUAL.
2. THE CONTRACTOR SHALL SCHEDULE A PRE-CONSTRUCTION CONFERENCE WITH THE DISTRICT ENGINEERING DEPARTMENT, (360) 424-7104, A MINIMUM OF 48 HOURS PRIOR TO CONSTRUCTION.
3. PERMITS FOR THE INSTALLATION OF THE PROPOSED WATER SYSTEM IMPROVEMENTS ARE ATTACHED IN APPENDIX B OF THE TECHNICAL SPECIFICATIONS.
4. DISTRICT REFERENCE DOCUMENTS, SUCH AS STANDARD DETAILS, WATER POLICY MANUAL, DRAWING STANDARDS, ETC., CAN BE FOUND ON THE DISTRICT WEBSITE AT WWW.SKAGITPUD.ORG.
5. ALL TIE-INS, SHUTDOWN, FLUSHING, AND HEALTH SAMPLES SHALL BE COORDINATED WITH THE DISTRICT. THE CONTRACTOR SHALL NOT OPERATE ANY VALVES. CONTRACTOR SHALL FURNISH ALL MATERIALS AND PERFORM ALL EXCAVATION, SHORING, DEWATERING, BACKFILL AND RESTORATION NECESSARY FOR DISTRICT CREWS TO PERFORM ALL TIE-INS TO ANY ACTIVE PUD OWNED AND OPERATED PIPELINE.
6. A LIST OF ALL MATERIALS, INDICATING THE MANUFACTURER, MODEL, AND SIZE, FOR THE WATER SYSTEM IMPROVEMENTS WILL BE APPROVED BY THE DISTRICT PRIOR TO CONSTRUCTION. CONTACT DISTRICT FOR SUBMITTAL REQUIREMENTS.
7. PVC PIPE SHALL BE IN ACCORDANCE WITH SECTION 9-30.1(5)A OF THE STANDARD SPECIFICATIONS.
8. MOLECULARLY ORIENTED POLYVINYL CHLORIDE (PVC) PIPE WILL BE PRESSURE CLASS 235 C900 PER AWWA C900-16 AND PER WSDOT STANDARD SPECIFICATION 9-30.1 AND 9-30.1(5)A. FITTINGS FOR PVC PIPE SHALL BE THE SAME AS SPECIFIED FOR DUCTILE IRON PER WSDOT STANDARD SPECIFICATIONS 9-30.2 AND 9-30.2(1). ALL DUCTILE IRON FITTINGS SHALL BE COMPLETELY WRAPPED WITH DENSO OR EQUIVALENT WAX TAPE SYSTEM. USE EPAA IRON SERIES 1900 AND 19MJ00, OR EQUIVALENT, TO RESTRAIN PIPE JOINTS FOR C909 PVC PIPE. INSTALLATION OF PVC PIPE SHALL BE IN ACCORDANCE WITH AWWA C605, CURRENT VERSION OF WSDOT STANDARD SPECIFICATIONS, AND PIPE MANUFACTURERS RECOMMENDATIONS.
9. ALL BOLTS USED IN BURIED FLANGES SHALL BE ASTM A307 GRADE B UNFINISHED WITH NUTS TO ASTM A563 GRADE A AND WASHERS TO ASTM F8444, OR ASTM A325 TYPE 3 (CORTEN STEEL) UNFINISHED, WITH NUTS TO ASTM A563C3 OR A563DH3 AND WASHERS TO ASTM F436-1. ALL BOLTS, NUTS AND WASHERS USED IN EXPOSED OR ABOVE GROUND LOCATIONS SHALL BE ASTM A307 GRADE B UNFINISHED OR HOT-DIP GALVANIZED.
10. ALL GATE VALVES TO BE RESILIENT SEATED GATE VALVES, AWWA C515 OR C509 (DUCTILE IRON BODY ONLY) WITH STAINLESS STEEL NUTS, BOLTS AND TRIM.
11. ALL BUTTERFLY VALVES TO BE RUBBER SEATED BUTTERFLY VALVES, AWWA C504 WITH STAINLESS STEEL NUTS, BOLTS AND TRIM.
12. ALL BURIED DUCTILE IRON FITTINGS AND VALVES SHALL BE WRAPPED WITH ANTI CORROSION WAX/PETROLEUM TAPE BY TRENTON ANTICORROSION MATERIALS INC, DENSO NORTH AMERICA INC OR EQUIVALENT.
13. RESTRAINED JOINTS MAY BE USED IN PLACE OF CONCRETE BLOCKING AS DIRECTED BY THE PROJECT'S DESIGN ENGINEER AND ACCEPTED BY THE DISTRICT.
14. ALL FIRE HYDRANTS SHALL CONFORM TO AWWA C502 WITH STORZ ADAPTORS. ACCEPTABLE FIRE HYDRANTS INCLUDE CLOW MEDALLION, MUELLER CENTURION OR SUPER CENTURION, AMERICAN DARLING B&B AND AMERICAN AVK NOSTALGIC.
15. A #10 SOLID COPPER WIRE WITH BLUE INSULATION IS TO BE INSTALLED WITH/AND ATTACHED TO ALL NEW WATER PIPELINES AND SERVICE PIPELINES. REFER TO DISTRICT DETAILS FOR INSTALLATION REQUIREMENTS.
16. UNLESS OTHERWISE SPECIFIED, ALL WATER PIPELINE INSTALLATIONS REQUIRE A 36-INCH MINIMUM COVER AND 48-INCH TYPICAL TRENCH DEPTH TO EXISTING OR FUTURE FINISH GRADE AND A MINIMUM OF 1-FOOT VERTICAL AND 5-FOOT HORIZONTAL CLEARANCE BETWEEN WATER PIPELINE AND ALL OTHER UTILITIES UNLESS OTHERWISE SPECIFIED.
17. WHEN INSTALLING WATER PIPELINE ACROSS EXISTING OR PROPOSED SANITARY SEWER, A FULL LENGTH OF PIPE SHALL BE INSTALLED WITH MID-SPAN OF THE WATER PIPE OVER THE SEWER. A MINIMUM 10-FOOT HORIZONTAL SEPARATION AND 18-INCH VERTICAL SEPARATION BETWEEN WATER PIPELINES AND SANITARY SEWER PIPELINES IS REQUIRED, UNLESS AN ALTERNATIVE PROPOSAL FROM THE DESIGN ENGINEER IS SUBMITTED TO AND APPROVED BY THE DISTRICT.
18. BEDDING MATERIAL FOR WATERLINES SHALL BE A MAXIMUM SIZE OF 1 1/2-INCHES AND PER WSDOT SPECIFICATION 7-09.3(9) AND 9-03.12(3). PEA GRAVEL AND BUCKSHOT ARE NOT ACCEPTABLE.
19. BACKFILL TRENCHES IN PAVEMENT AREAS WITH PIT-RUN GRAVEL COMPACTED TO AT LEAST 95 PERCENT MINIMUM DENSITY PER WSDOT SPECIFICATION 7-09.3(11). THE CONTRACTOR SHALL MAKE ALL PAVEMENT REPAIRS AND PERFORM ALL RESTORATION.
20. DISINFECTION AND FLUSHING OF THE WATER PIPELINES ARE TO BE PER WSDOT SPECIFICATIONS AND AWWA C651-14. USE DE-CHLORINATION EQUIPMENT WHEN FLUSHING OR, WITH PERMISSION OF THE APPROPRIATE SEWER UTILITY, FLUSH INTO SANITARY SEWER MANHOLES. DO NOT FLUSH INTO OR ALLOW CHLORINATED WATER TO DRAIN INTO ANY CREEK, WETLAND, OR CATCH BASIN. THE CONTRACTOR WILL SUBMIT A PRESSURE TESTING, DISINFECTION, AND FLUSHING PLAN TO THE DISTRICT PRIOR TO CONSTRUCTION.
21. ALL SALVAGED USABLE DISTRICT OWNED MATERIALS ARE TO BE DELIVERED TO THE DISTRICT OFFICE AT 1415 FREEWAY DRIVE, MOUNT VERNON, OR AS DIRECTED BY THE DISTRICT.
22. THE UTILITY LOCATIONS MARKED ON THIS MAP ARE APPROXIMATE. THE CONTRACTOR IS TO VERIFY ACTUAL LOCATION AND DEPTH PRIOR TO CONSTRUCTION. CALL THE UNDERGROUND UTILITY LOCATE CENTER AT 800-424-5555.
23. ALL PRIVATE FIRE SPRINKLERS OR PRIVATE FIRE HYDRANT PIPELINES ARE REQUIRED TO BE INSTALLED WITH A WASHINGTON STATE DEPARTMENT OF HEALTH (WSDOH) APPROVED DOUBLE CHECK DETECTOR ASSEMBLY(IES) OR REDUCED PRESSURE DETECTOR ASSEMBLY(IES), LOCATED IMMEDIATELY AFTER THE FIRE SERVICE CONNECTION. A BADGER RECORDALL METER WITH A REMOTE TOUCH-READ PAD WILL BE SUPPLIED AND INSTALLED BY THE DISTRICT WITHIN 6-INCHES OF THE VAULT LID'S HINGE AND BRASS PLUGS IN THE TEST PORTS. METER SUPPLY AND INSTALLATION WILL BE INCLUDED WITH THE CHARGES IN THE WORK ORDER.
24. A LEAD FREE, WASHINGTON STATE APPROVED, REDUCED PRESSURE BACKFLOW PREVENTION ASSEMBLY SHALL BE INSTALLED AT TEMPORARY CONNECTIONS BETWEEN THE EXISTING DISTRICT PIPELINES AND NEW WATER PIPELINES FOR FILLING, FLUSHING AND PRESSURE TESTING OF THE IMPROVEMENTS. UPON TEMPORARY CONNECTION, AND PRIOR TO FILLING, THE ASSEMBLY SHALL HAVE BEEN SUCCESSFULLY TESTED BY A BACKFLOW ASSEMBLY TESTER (BAT) AND THE TEST REPORT IS TO BE PROVIDED TO THE DISTRICT.
25. BEFORE FINAL CONNECTION TO THE EXISTING DISTRICT SYSTEM, ALL NEW WATER PIPELINES AND REPAIRED PORTIONS OF/OR EXTENSION TO EXISTING PIPELINES SHALL BE ADEQUATELY DISINFECTED AND A SATISFACTORY BACTERIOLOGICAL REPORT OBTAINED.
26. PRESSURE TEST NEW PIPELINE, INCLUDING FIRE HYDRANTS AND SERVICE LINES AS PER WSDOT STANDARDS.

## CONSTRUCTION NOTES

1. VERIFY THE LOCATIONS, ELEVATIONS, DIAMETERS, MATERIALS, AND OTHER PARAMETERS OF EXISTING FACILITIES TO WHICH NEW FACILITIES CONNECT BEFORE BEGINNING ANY WORK.
2. VERIFY INVERT ELEVATION OF EXISTING UTILITIES BY POTHOLING A MINIMUM OF 200 FEET AHEAD OF WATERLINE INSTALLATION.
3. PROTECT ALL EXISTING UTILITIES, SERVICE CONNECTIONS AND ALL SURFACE IMPROVEMENTS. CONTRACTOR SHALL REPAIR ALL SERVICE CONNECTIONS WHETHER SHOWN ON THESE PLANS OR NOT.
4. PROTECT ALL EXISTING UTILITIES AND SURFACE IMPROVEMENTS. CONTRACTORS SHALL COORDINATE WITH PROPERTY OWNERS DURING CONSTRUCTION TO AVOID DAMAGING EXISTING FACILITIES. CONTRACTOR SHALL BE RESPONSIBLE TO IDENTIFY AND LOCATE ALL EXISTING UTILITIES ON PRIVATE PROPERTY.
5. CONSTRUCTION ACTIVITIES SHALL NOT EXTEND BEYOND THE LIMITS SHOWN IN THE PLANS WITHOUT PRIOR APPROVAL OF THE ENGINEER.
6. CONTRACTOR TO COORDINATE WORK WITH & WITHIN APPROVED TRAFFIC CONTROL PLANS.
7. REFER TO EROSION AND SEDIMENTATION CONTROL DRAWINGS FOR PROTECTION AND RESTORATION REQUIREMENTS.
8. CONTRACTOR IS RESPONSIBLE FOR CONSTRUCTING, MAINTAINING AND REMOVING TEMPORARY ACCESS ROADS AND RESTORATION OF CONSTRUCTION AREAS TO PRE-CONSTRUCTION CONDITION OR BETTER.
9. PROVIDE AND MAINTAIN TEMPORARY PAVEMENT MARKINGS UNTIL PERMANENT MARKINGS RESTORATION. PROVIDE PERMANENT RESTORATION OF PAVEMENT MARKINGS AFTER PAVEMENT RESTORATION IS COMPLETED.
10. SUPPORT POWER AND TELEPHONE POLES DURING PIPELINE INSTALLATION. COORDINATE WITH PUGET SOUND ENERGY TO PROVIDE TEMPORARY GUYS OR SUPPORTS AS NECESSARY.
11. EXCESS TRENCH MATERIALS MUST BE HAULED OFF SITE. NO SPOILS SHALL BE SPREAD IN WETLANDS OR WETLAND BUFFERS. NO MATERIALS SHALL BE STOCKPILED IN WETLANDS OR WETLAND BUFFERS.
12. REMOVE AND REPLACE ALL MAILBOXES AS REQUIRED FOR CONSTRUCTION OF THE PIPELINE.
13. REMOVE AND REPLACE ALL TRAFFIC AND ROADWAY SIGNS AS REQUIRED FOR CONSTRUCTION.
14. MINIMUM 12-INCH SAND CUSHION IS DESIRED BETWEEN WATERLINE AND EXISTING PIPELINES OR OTHER CONDUITS WHEN ENCOUNTERED DURING CONSTRUCTION. NOTIFY DISTRICT INSPECTOR IF LESS THAN 12-INCHES OF CUSHION WILL OCCUR.
15. TURBID WATER GENERATED FROM CONSTRUCTION ACTIVITIES, INCLUDING TURBID DEWATERING WATER, SHALL NOT BE DISCHARGED DIRECTLY TO ANY SURFACE WATER. TEMPORARY SEDIMENT PONDS OR BAKER TANKS SHALL BE USED, AS NECESSARY, TO ALLOW THE TURBID WATER TO SETTLE BEFORE DISCHARGE. DEWATERED GROUNDWATER CAN BE TREATED USING BAKER TANKS ONSITE OR TREATED AND DISPOSED OFFSITE, UPON APPROVAL OF ENGINEER, AND PER APPLICABLE RULES AND GUIDELINES OF DEPARTMENT OF ECOLOGY AND OTHER REQUIREMENTS OF APPLICABLE JURISDICTIONS.
16. THE CONTRACTOR SHALL BE RESPONSIBLE FOR EXCAVATION, SHORING, DEWATERING, TRAFFIC CONTROL, CONCRETE THRUST BLOCKING, BACKFILL, COMPACTION AND SURFACE RESTORATION WORK NECESSARY FOR DISTRICT'S COMPLETION OF FINAL TIE-INS TO EXISTING SYSTEM. CONTRACTOR SHALL PROVIDE A MINIMUM 3 DAY NOTICE TO DISTRICT BEFORE TIE-IN WORK TO BE COMPLETED.

TEST DATE _____	TEST PRESSURE _____
TIME START _____	TIME END _____
PRESSURE DROP _____	MAKE-UP WATER _____
TEST DATE _____	TEST PRESSURE _____
TIME START _____	TIME END _____
PRESSURE DROP _____	MAKE-UP WATER _____
TEST DATE _____	TEST PRESSURE _____
TIME START _____	TIME END _____
PRESSURE DROP _____	MAKE-UP WATER _____
TEST DATE _____	TEST PRESSURE _____
TIME START _____	TIME END _____
PRESSURE DROP _____	MAKE-UP WATER _____

ISSUE	REVISIONS	BY	DATE
1.	ISSUED FOR BIDDING	GJS	11/19/14
2.	ISSUED FOR BIDDING	MCH	7/21/22

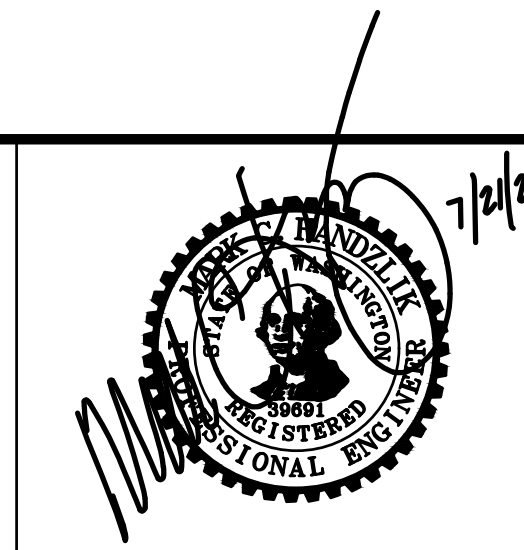

DATUM: HOR: ASSUMED VERT: NAVD 88		DSGN BY: MED DWN BY: MDO APPVD BY: MCH	
CALL 48 HOURS BEFORE YOU DIG 1-800-424-5555			
DATE PRINTED: 7/28/22	SEC: 8 TWP: 34 N RGE: 2 E		



PUBLIC UTILITY DISTRICT  
NO. 1 of SKAGIT COUNTY  
1415 Freeway Drive  
Mount Vernon, WA 98273  
(360) 424-7104  
www.SkagitPud.org

SATTERLEE ROAD, GIBRALTER ROAD TO DRIVER ROAD PHASE I GENERAL NOTES		
SCALE: NONE	P.N. 3505 C.O. 4811	SHEET: 2 OF 11

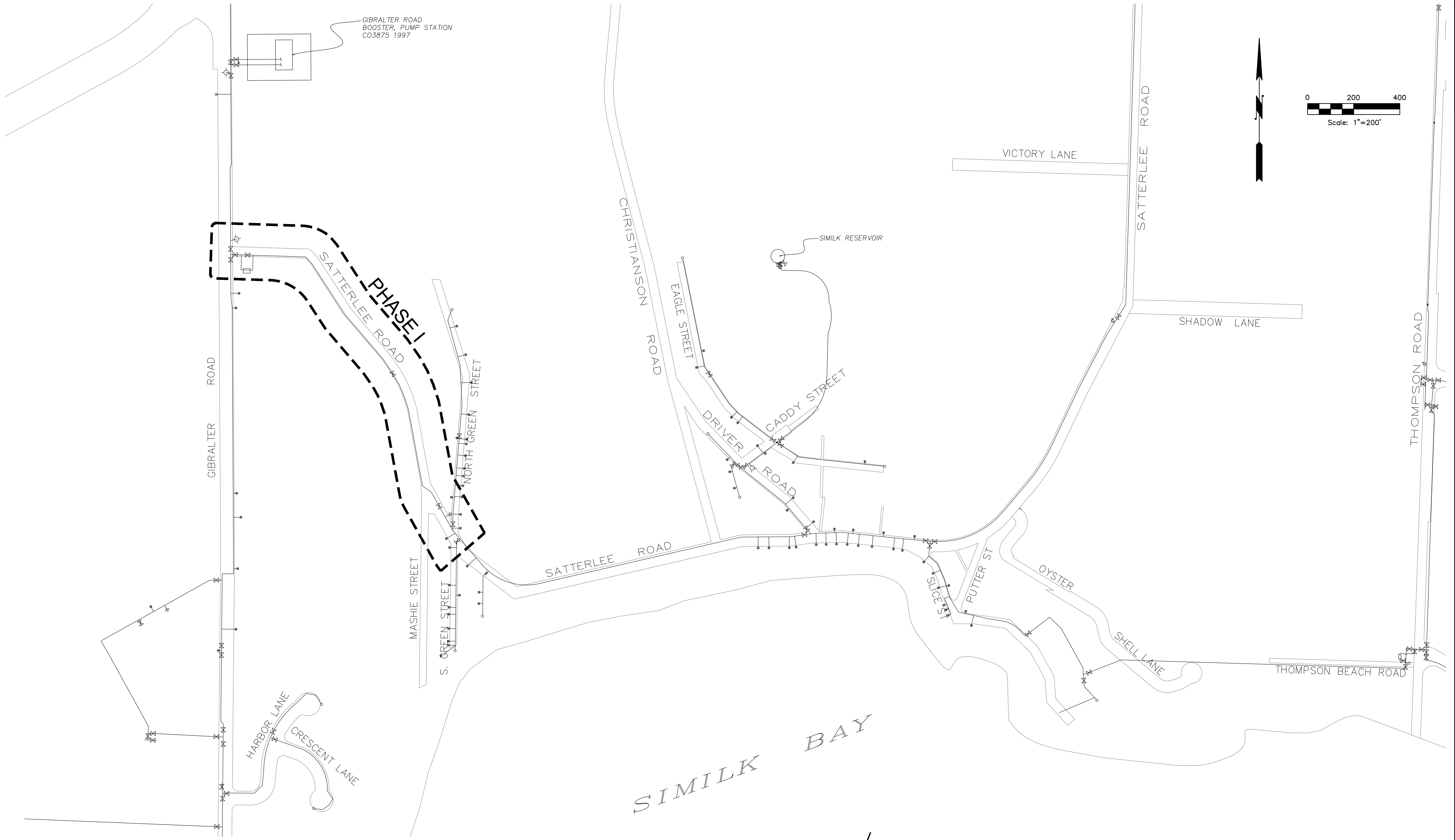

GIBRALTER ROAD  
BOOSTER, PUMP STATION  
C03875 1997

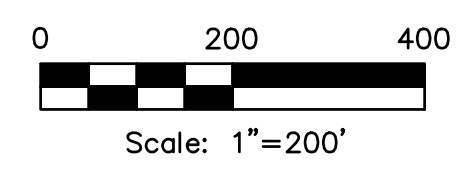

ISSUE	REVISIONS	BY	DATE
1.	ISSUED FOR BIDDING	GJS	11/19/14
2.	ISSUED FOR BIDDING	MCH	7/21/22

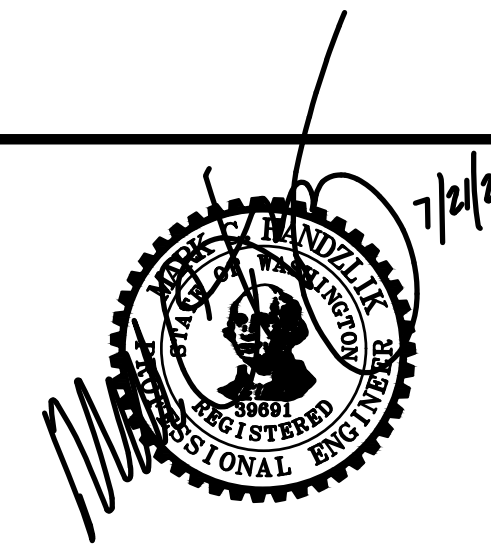

DATUM: HOR: ASSUMED VERT: NAVD 88	DSGN BY: MED DWN BY: MDO APPVD BY: MCH
CALL 48 HOURS BEFORE YOU DIG 1-800-424-5555	
DATE PRINTED: 7/28/22	SEC: 8 TWP: 34 N RGE: 2 E



PUBLIC UTILITY DISTRICT  
NO. 1 of SKAGIT COUNTY  
1415 Freeway Drive  
Mount Vernon, WA 98273  
(360) 424-7104  
www.SkagitPud.org

SATTERLEE ROAD, GIBRALTER ROAD TO DRIVER ROAD PHASE I SHUTDOWN MAP		
SCALE: 1"=200'	P.N. 3505 C.O. 4811	SHEET: 3 OF 11



**Standard ESC Plan Notes**

- AS DIRECTED BY PUBLIC WORKS DIRECTOR PRIOR TO COMMENCING CONSTRUCTION, ALL CRITICAL AREAS, INCLUDING WETLAND BUFFERS, STREAM CORRIDOR, LANDFILL AREAS, AND STEEP SLOPES SHALL BE CONTINUOUSLY DEMARCATED IN THE FIELD USING FLAGGING TAPE OR FENCING.
- EROSION CONTROL METHODS AND MATERIALS SHALL MEET REQUIREMENTS OF SECTION 8-01 OF THE APWA/WASHINGTON STATE DEPARTMENT OF TRANSPORTATION 1998 STANDARD SPECIFICATIONS FOR ROAD, BRIDGE, AND MUNICIPAL CONSTRUCTION, AND REQUIREMENTS SET FORTH IN VOLUME II OF THE "STORMWATER MANAGEMENT MANUAL FOR THE PUGET SOUND BASIN (THE TECHNICAL MANUAL)", BY THE WASHINGTON STATE DEPARTMENT OF ECOLOGY, CURRENT EDITION. THE CONTRACTOR SHALL FOLLOW RECOMMENDATIONS MADE BY SUPPLIERS AND MANUFACTURERS OF MATERIALS AND EQUIPMENT USED.
- THE ESC FACILITIES SHOWN ON THIS PLAN MUST BE CONSTRUCTED IN CONJUNCTION WITH ALL CLEARING AND GRADING ACTIVITIES IN SUCH A MANNER AS TO ENSURE THAT SEDIMENT-LADEN WATER DOES NOT ENTER THE DRAINAGE SYSTEM OR VIOLATE APPLICABLE WATER STANDARDS, AND MUST BE INSTALLED AND IN OPERATION PRIOR TO ANY GRADING OR LAND CLEARING. WHEREVER POSSIBLE, MAINTAIN NATURAL VEGETATION FOR SILT CONTROL.
- THE ESC FACILITIES SHOWN ON THIS PLAN ARE THE MINIMUM REQUIREMENTS FOR ANTICIPATED SITE CONDITIONS. DURING THE CONSTRUCTION PERIOD, THESE ESC FACILITIES SHALL BE UPGRADED (E.G. ADDITIONAL SUMPS, RELOCATION OF DITCHES AND SILT FENCES, ETC.) AS NEEDED FOR UNEXPECTED STORM EVENTS. ADDITIONALLY, MORE ESC FACILITIES MAY BE REQUIRED TO ENSURE COMPLETE SILTATION CONTROL. THEREFORE, DURING THE COURSE OF CONSTRUCTION, IT SHALL BE THE OBLIGATION AND RESPONSIBILITY OF THE CONTRACTOR TO ADDRESS ANY NEW CONDITIONS THAT MAY BE CREATED BY HIS ACTIVITIES AND TO PROVIDE ADDITIONAL FACILITIES OVER AND ABOVE THE MINIMUM REQUIREMENTS AS MAY BE NEEDED.
- ANY PERMANENT RETENTION/DETENTION FACILITY USED AS A TEMPORARY SETTLING BASIN SHALL BE MODIFIED WITH THE NECESSARY EROSION CONTROL MEASURES AND SHALL PROVIDE ADEQUATE STORAGE CAPACITY. IF THE PERMANENT FACILITY IS TO FUNCTION ULTIMATELY AS AN INFILTRATION OR DISPERSION SYSTEM, THE FACILITY SHALL NOT BE USED AS A TEMPORARY SETTLING BASIN. NO UNDERGROUND DETENTION TANK, DETENTION VAULT, OR SYSTEM, WHICH BACKS UNDER OR INTO A POND, SHALL BE USED AS A TEMPORARY SETTLING BASIN.
- WHERE SEEDING FOR TEMPORARY EROSION CONTROL IS REQUIRED, FAST GERMINATING GRASSES SHALL BE APPLIED AT AN APPROPRIATE RATE (EXAMPLE: ANNUAL OR PERENNIAL RYE APPLIED AT APPROXIMATELY 80 POUNDS PER ACRE).
- WHERE STRAW MULCH IS REQUIRED FOR TEMPORARY EROSION CONTROL, IT SHALL BE APPLIED AT A MINIMUM THICKNESS OF TWO (2) INCHES.
- ALL WORK AND MATERIALS SHALL BE IN ACCORDANCE WITH SPECIFICATIONS OF THE CITY OR COUNTY IN WHICH THE WORK OCCURS.
- THE ESC FACILITIES SHALL BE CONSTRUCTED IN ACCORDANCE WITH THE DETAILS ON THE APPROVED PLANS. LOCATIONS MAY BE MOVED TO SUIT FIELD CONDITIONS, SUBJECT TO APPROVAL.
- A COPY OF THE APPROVED EROSION CONTROL PLANS MUST BE ON THE JOB SITE WHENEVER CONSTRUCTION IS IN PROGRESS.
- OFF-SITE STREETS MUST BE KEPT CLEAN AT ALL TIMES. IF DIRT IS DEPOSITED ON THE PUBLIC STREET SYSTEM, THE STREET SHALL BE IMMEDIATELY CLEANED WITH POWER SWEEPER OR OTHER EQUIPMENT. ALL VEHICLES SHALL LEAVE THE SITE BY WAY OF THE CONSTRUCTION ENTRANCE AND SHALL BE CLEANED OF ALL DIRT THAT WOULD BE DEPOSITED ON THE PUBLIC STREETS.
- ANY CATCH BASINS COLLECTING RUNOFF FROM THE SITE, WHETHER THEY ARE ON OR OFF THE SITE, SHALL HAVE THEIR GRATES COVERED WITH FILTER FABRIC DURING CONSTRUCTION.
- THE WASHED GRAVEL BACKFILL ADJACENT TO THE FILTER FABRIC FENCE SHALL BE REPLACED AND THE FILTER FABRIC CLEANED IF IT IS NONFUNCTIONAL BY EXCESSIVE SILT ACCUMULATION. ALL INTERCEPTOR SWALES SHALL BE CLEANED IF SILT ACCUMULATION EXCEEDS ONE-QUARTER DEPTH.

- ROCK FOR EROSION PROTECTION OF ROADWAY DITCHES, WHERE REQUIRED, MUST BE OF SOUND QUARRY ROCK, PLACED TO DEPTH OF ONE (1) FOOT AND MUST MEET THE FOLLOWING SPECIFICATIONS: 4" - 8" ROCK/40%-70% PASSING; 2"-4" ROCK/30%-40% PASSING; AND 1"-2" ROCK/10%-20% PASSING.
- IF ANY PART (S) OF THE CLEARING LIMIT; BOUNDARY OR TEMPORARY EROSION/SEDIMENTATION CONTROL PLAN IS/ARE DAMAGED, IT SHALL BE REPAIRED IMMEDIATELY.
- ALL PROPERTIES ADJACENT TO THE PROJECT SITE SHALL BE PROTECTED FROM SEDIMENT DEPOSITION AND RUNOFF DO NOT FLUSH CONCRETE BY PRODUCTS OR TRUCKS NEAR OR INTO THE STORM DRAINAGE SYSTEM. IF EXPOSED AGGREGATE IS FLUSHED INTO THE STORM SYSTEM, IT COULD MEAN RECLEANING THE ENTIRE DOWNSTREAM STORM SYSTEM, OR POSSIBLY RELAYING THE STORM LINE.
- THE IMPLEMENTATION OF THESE ESC PLANS AND THE CONSTRUCTION, MAINTENANCE, REPLACEMENT, AND UPGRADING OF THESE FACILITIES IS THE RESPONSIBILITY OF THE APPLICANT/ESC SUPERVISOR UNTIL ALL CONSTRUCTION IS APPROVED.
- THE ESC LEAD'S NAME IS: \_\_\_\_\_
- THE APPLICANT'S NAME IS : PUD NO. 1 OF SKAGIT COUNTY, 24 HR. CONTACT NUMBER: 360-424-7104.
- THE ESC FACILITIES SHALL BE INSPECTED DAILY BY THE APPLICANT/ESC LEAD AND MAINTAINED TO ENSURE CONTINUED PROPER FUNCTIONING. WRITTEN RECORDS SHALL BE KEPT OF WEEKLY REVIEWS OF THE ESC FACILITIES DURING THE WET SEASON (OCT. 1 TO APRIL 30) AND OF THE MONTHLY REVIEWS DURING THE DRY SEASON (MAY 1 TO SEPT. 30).
- ANY AREAS OF EXPOSED SOILS, INCLUDING ROADWAY EMBANKMENTS, THAT WILL NOT BE DISTURBED FOR TWO DAYS DURING THE WET SEASON OR SEVEN DAYS DURING THE DRY SEASON SHALL BE IMMEDIATELY STABILIZED WITH THE APPROVED ESC METHODS (E.G., SEEDING, MULCHING, PLASTIC COVERING, ETC.).
- ANY AREA NEEDING ESC MEASURES NOT REQUIRING IMMEDIATE ATTENTION SHALL BE ADDRESSED WITHIN FIFTEEN (15) DAYS.
- THE ESC FACILITIES ON ACTIVE SITES SHALL BE INSPECTED AND MAINTAINED A MINIMUM OF ONCE A MONTH OR WITHIN FORTY-EIGHT (48) HOURS FOLLOWING A STORM EVENT.
- AT NO TIME SHALL MORE THAN ONE (1) FOOT OF SEDIMENT BE ALLOWED TO ACCUMULATE WITHIN A CATCH BASIN. ALL CATCH BASINS AND CONVEYANCE LINES SHALL BE CLEANED PRIOR TO PAVING. THE CLEANING OPERATION SHALL NOT FLUSH SEDIMENT-LADEN WATER INTO THE DOWNSTREAM SYSTEM.
- STABILIZED CONSTRUCTION ENTRANCES AND ROADS SHALL BE INSTALLED AT THE BEGINNING OF CONSTRUCTION AND MAINTAINED FOR THE DURATION OF THE PROJECT. ADDITIONAL MEASURES, SUCH AS WASH PADS, MAY BE REQUIRED TO ENSURE THAT ALL PAVED AREAS ARE KEPT CLEAN FOR THE DURATION OF THE PROJECT.
- ANY PERMANENT FLOW CONTROL FACILITY USED AS A TEMPORARY SETTLING BASIN SHALL BE MODIFIED WITH THE NECESSARY EROSION CONTROL MEASURES AND SHALL PROVIDE ADEQUATE STORAGE CAPACITY. IF THE FACILITY IS TO FUNCTION AS ULTIMATELY AS AN INFILTRATION SYSTEM, THE TEMPORARY FACILITY MUST BE GRADED SO THAT THE BOTTOM AND SIDES ARE AT LEAST THREE FEET ABOVE THE FINAL GRADE OF THE PERMANENT FACILITY.
- PRIOR TO THE BEGINNING OF THE WET SEASON (OCT. 1), ALL DISTURBED AREAS SHALL BE REVIEWED TO IDENTIFY WHICH ONES CAN BE SEEDED IN PREPARATION FOR THE WINTER RAINS. DISTURBED AREAS SHALL BE SEEDED WITHIN ONE WEEK OF THE BEGINNING OF THE WET SEASON. A SKETCH MAP OF THOSE AREAS TO BE SEEDED AND THOSE AREAS TO REMAIN UNCOVERED SHALL BE SUBMITTED TO THE CITY INSPECTOR. THE CITY INSPECTOR CAN REQUIRE SEEDING OF ADDITIONAL AREAS IN ORDER TO PROTECT SURFACE WATERS, ADJACENT PROPERTIES, OR DRAINAGE FACILITIES.
- CONTRACTOR SHALL MAINTAIN ALL BMP'S UNTIL DISTURBED AREAS HAVE STABILIZED.

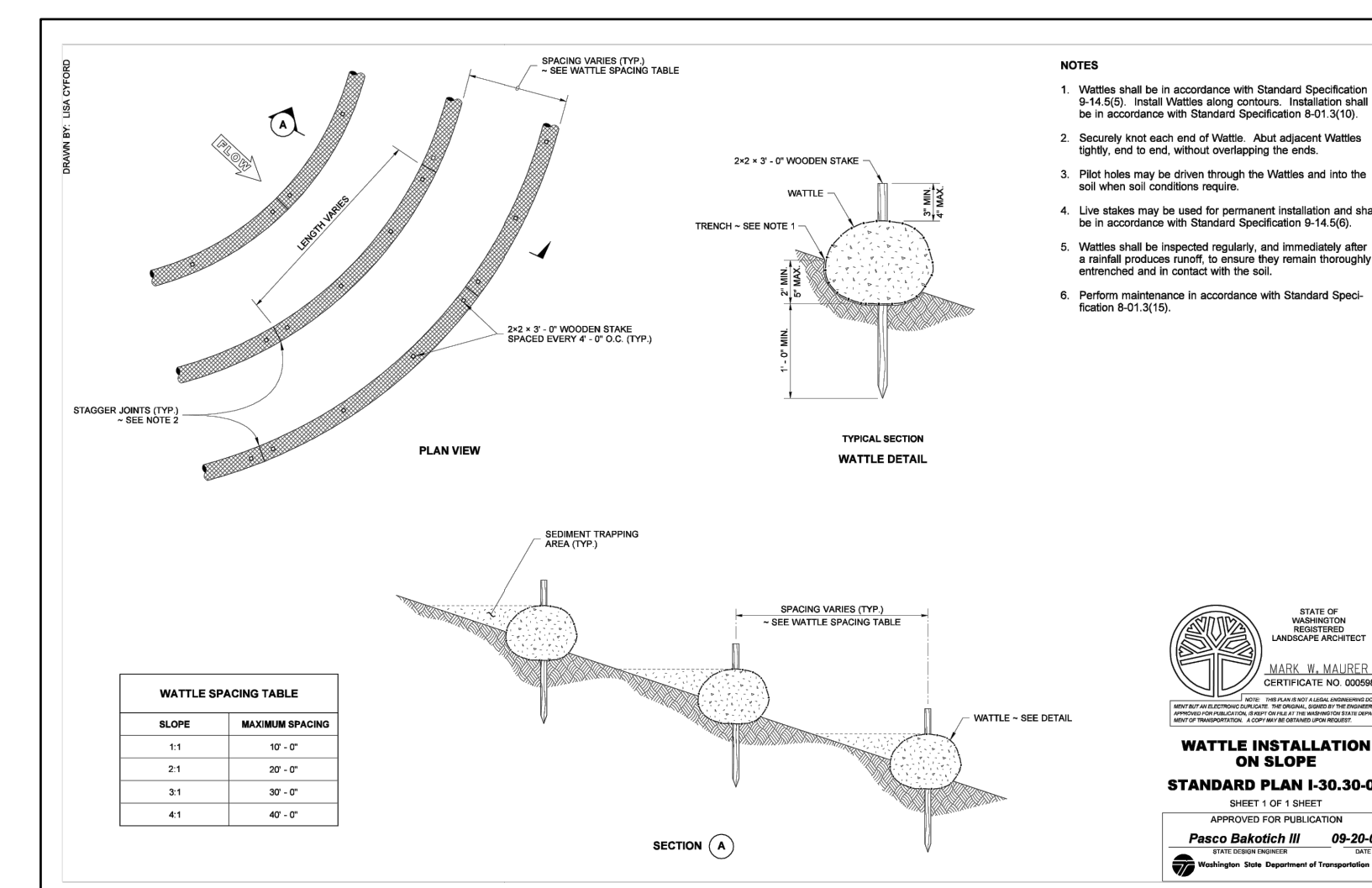
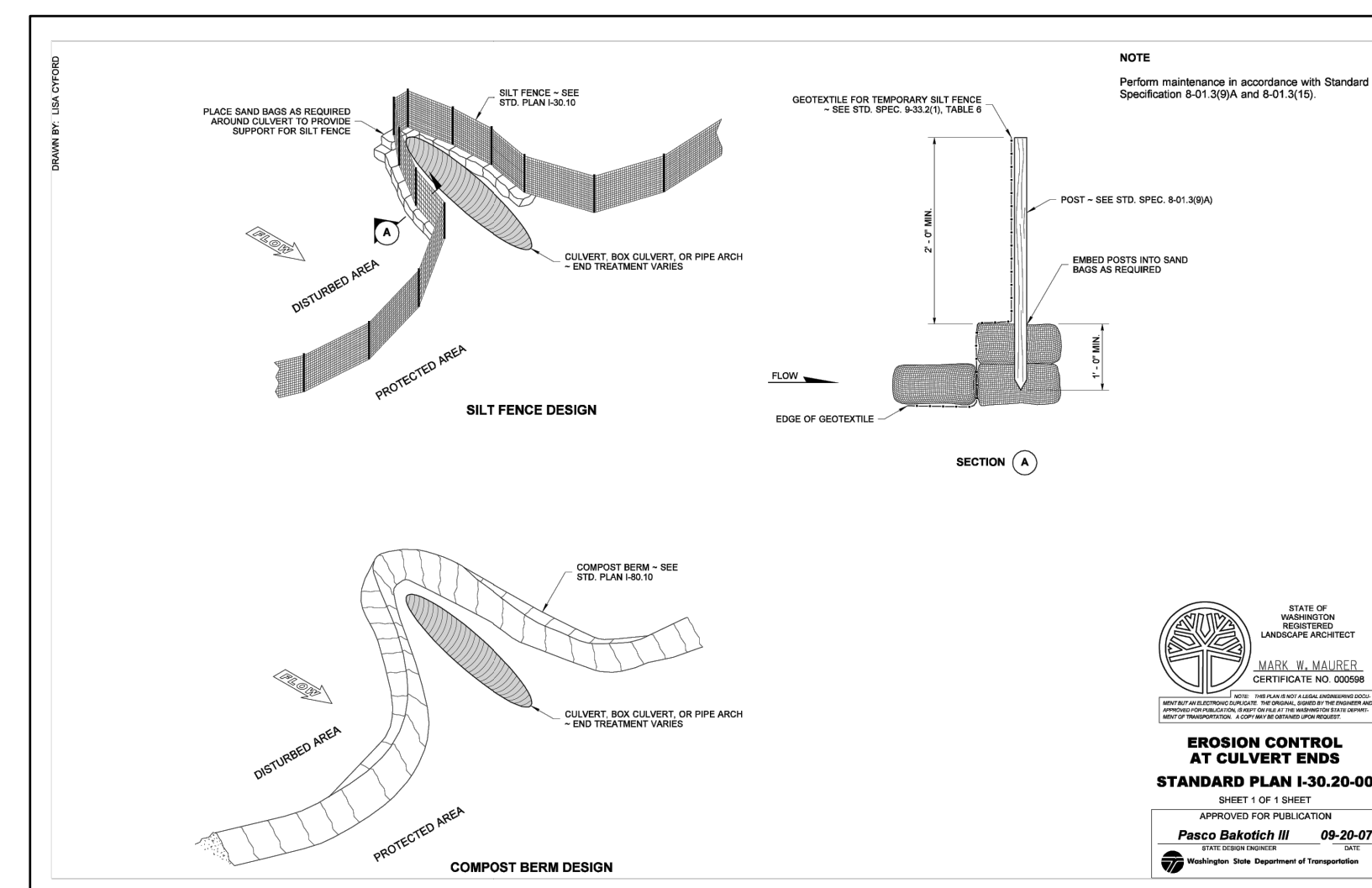
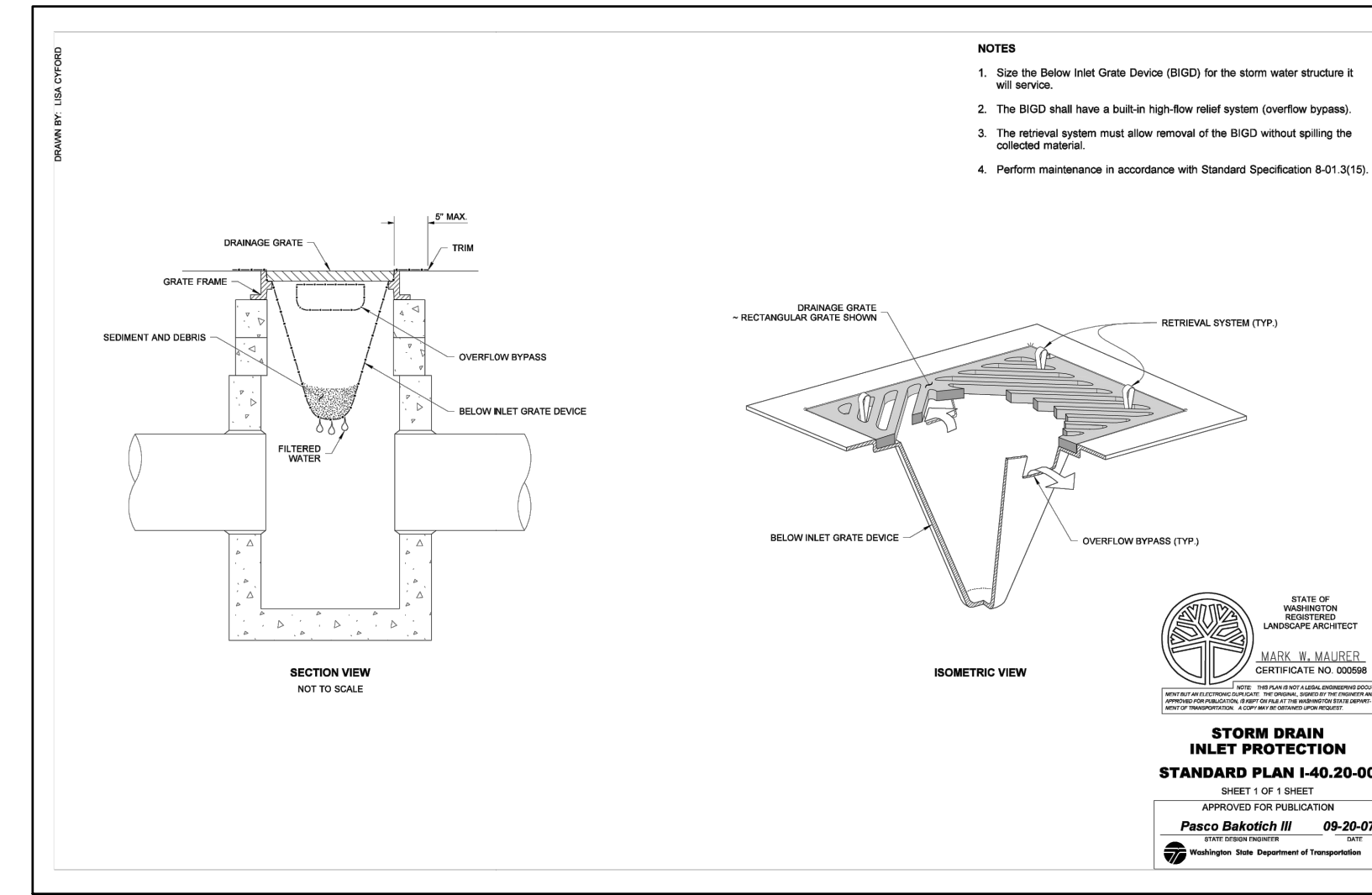

ISSUE	REVISIONS	BY	DATE
1.	ISSUED FOR BIDDING	GJS	11/19/14
2.	ISSUED FOR BIDDING	MCH	7/21/22



DATUM:  
HOR: ASSUMED  
VERT: NAVD 88

DSGN BY: MED  
DWN BY: MDO  
APPVD BY: MCH

CALL 48 HOURS BEFORE YOU DIG  
1-800-424-5555

DATE PRINTED: 7/28/22  
SEC: 8  
TWP: 34 N  
RGE: 2 E

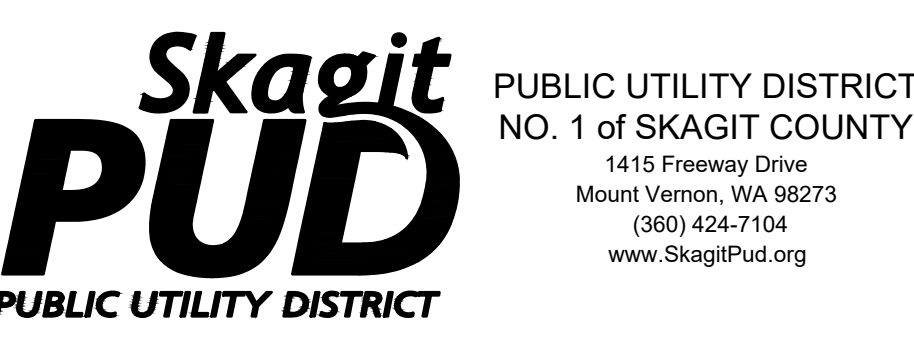

SATTERLEE ROAD, GIBRALTER ROAD TO DRIVER ROAD  
PHASE I  
EROSION AND SEDIMENTATION CONTROL NOTES AND DETAILS

SCALE: NONE

P.N. 3505  
C.O. 4811

SHEET:  
4 OF 11

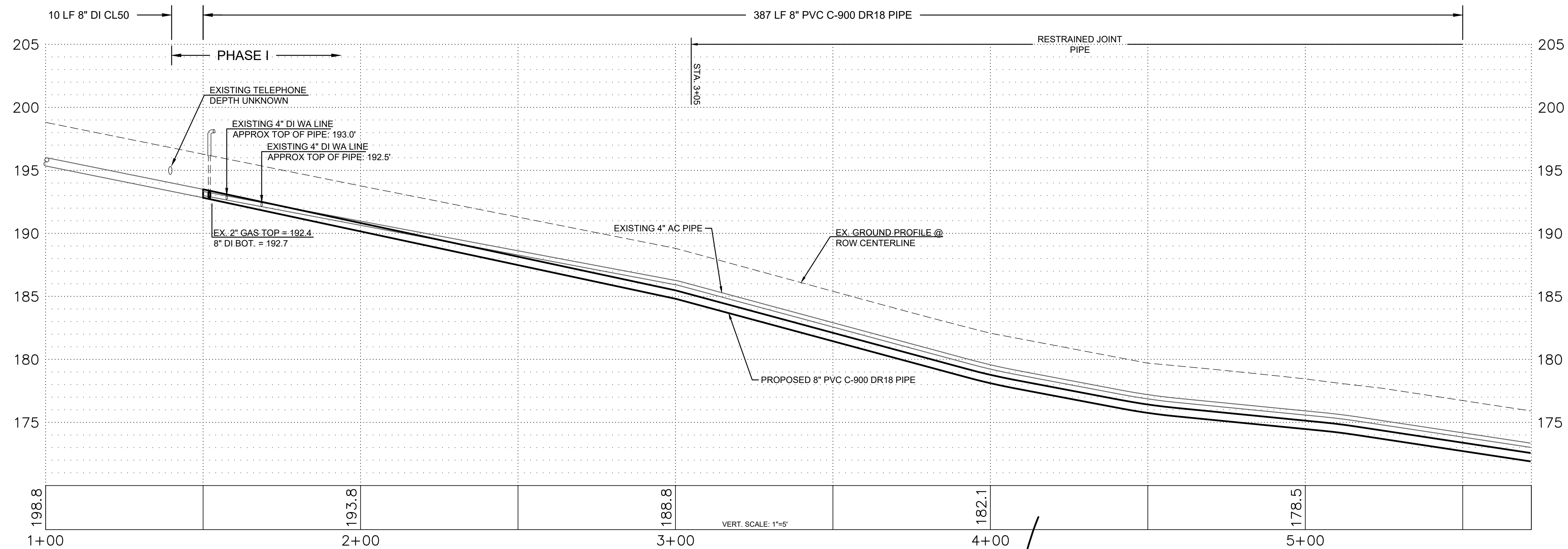
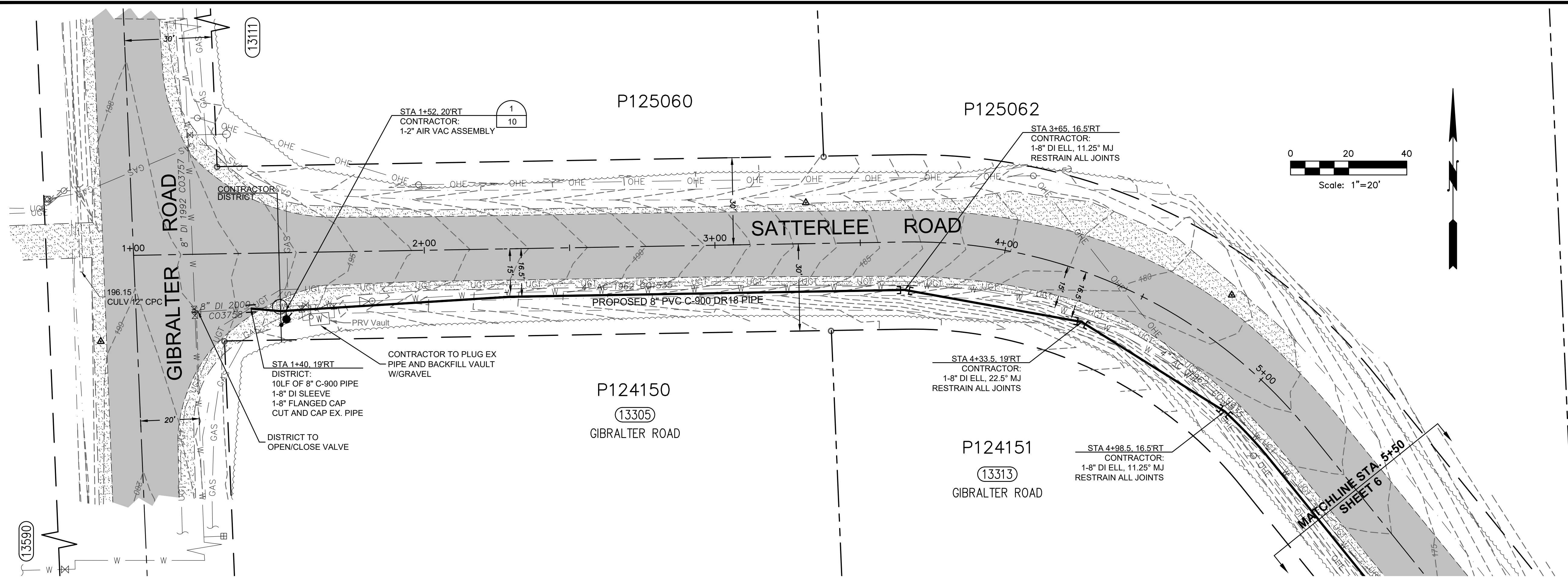

ISSUE	REVISIONS	BY	DATE
1.	ISSUED FOR BIDDING	GJS	11/19/14
2.	ISSUED FOR BIDDING	MCH	7/21/22

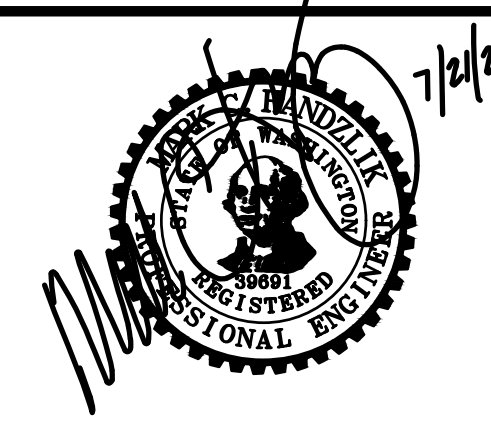
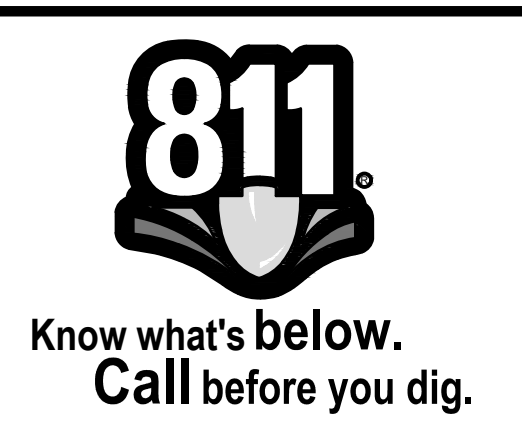

DATUM:  
HOR: ASSUMED  
VERT: NAVD 88

DSGN BY: MED  
DWN BY: MDO  
APPVD BY: MCH

CALL 48 HOURS  
BEFORE YOU DIG  
1-800-424-5555

DATE PRINTED: 7/28/22  
SEC: 8  
TWP: 34 N  
RGE: 2 E

**Skagit PUD**  
PUBLIC UTILITY DISTRICT

PUBLIC UTILITY DISTRICT  
NO. 1 of SKAGIT COUNTY  
1415 Freeway Drive  
Mount Vernon, WA 98273  
(360) 424-7104  
www.SkagitPud.org



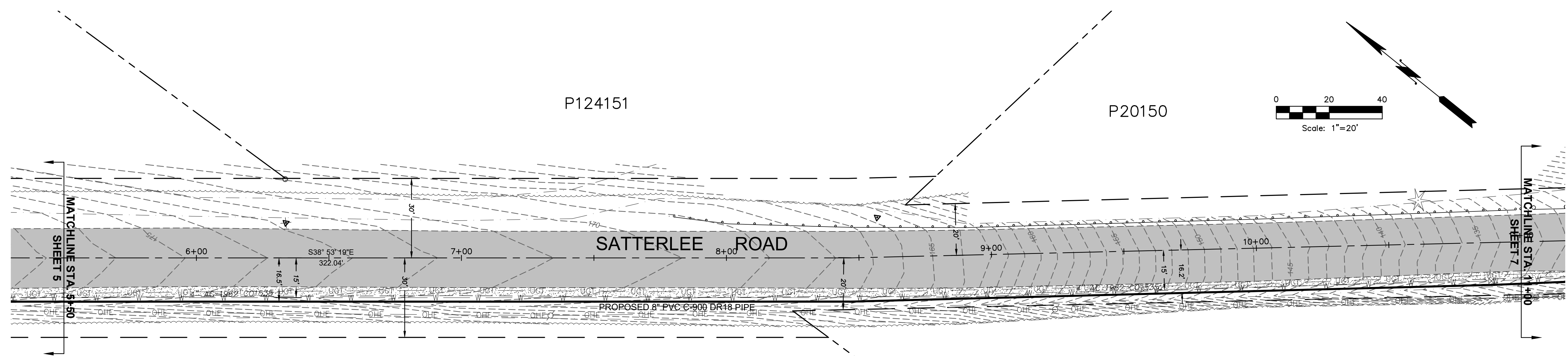

P124151  
 (13313)  
 GIBRALTER ROAD

P20150  
 (13395)  
 GIBRALTER ROAD

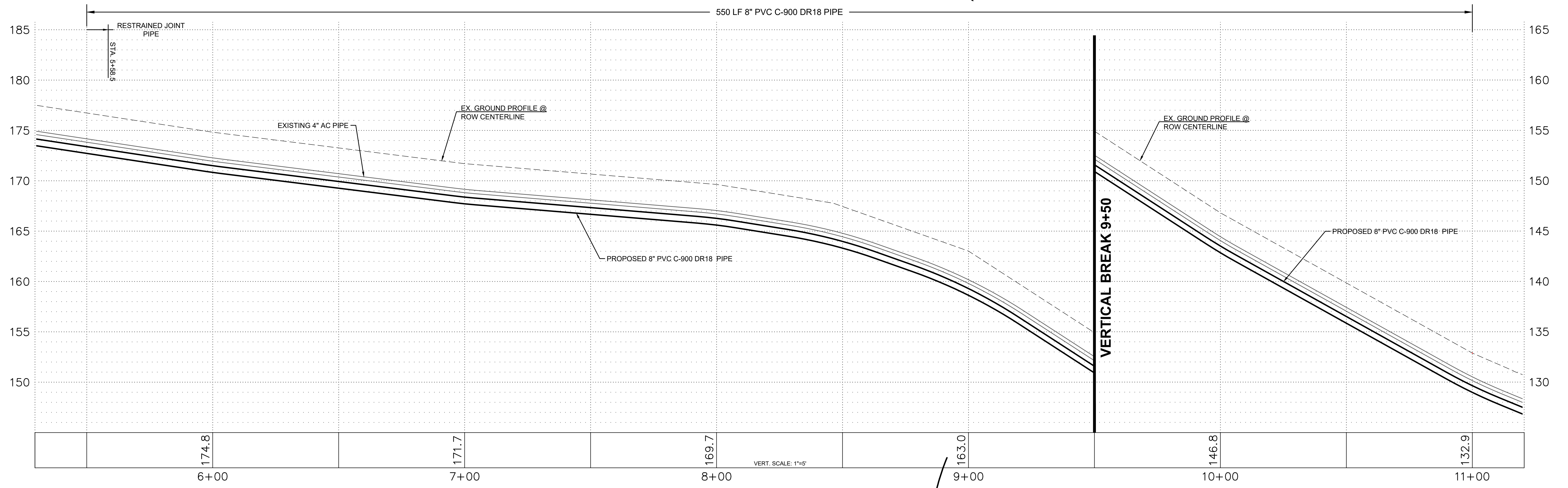

ISSUE	REVISIONS	BY	DATE
1.	ISSUED FOR BIDDING	GJS	11/19/14
2.	ISSUED FOR BIDDING	MCH	7/21/22

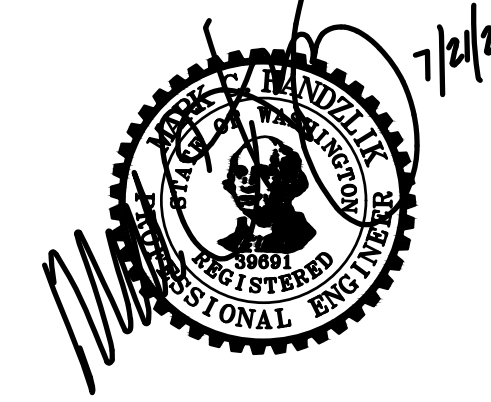

DATUM:  
 HOR: ASSUMED  
 VERT: NAVD 88

DSGN BY: MED  
 DWN BY: MDO  
 APPVD BY: MCH

CALL 48 HOURS  
 BEFORE YOU DIG  
 1-800-424-5555

DATE PRINTED: 7/28/22  
 SEC: 8  
 TWP: 34 N  
 RGE: 2 E



PUBLIC UTILITY DISTRICT  
 NO. 1 of SKAGIT COUNTY  
 1415 Freeway Drive  
 Mount Vernon, WA 98273  
 (360) 424-7104  
 www.SkagitPud.org

SATTERLEE ROAD, GIBRALTER ROAD TO  
 DRIVER ROAD  
 PHASE I  
 PLAN AND PROFILE 5+50 TO 11+00



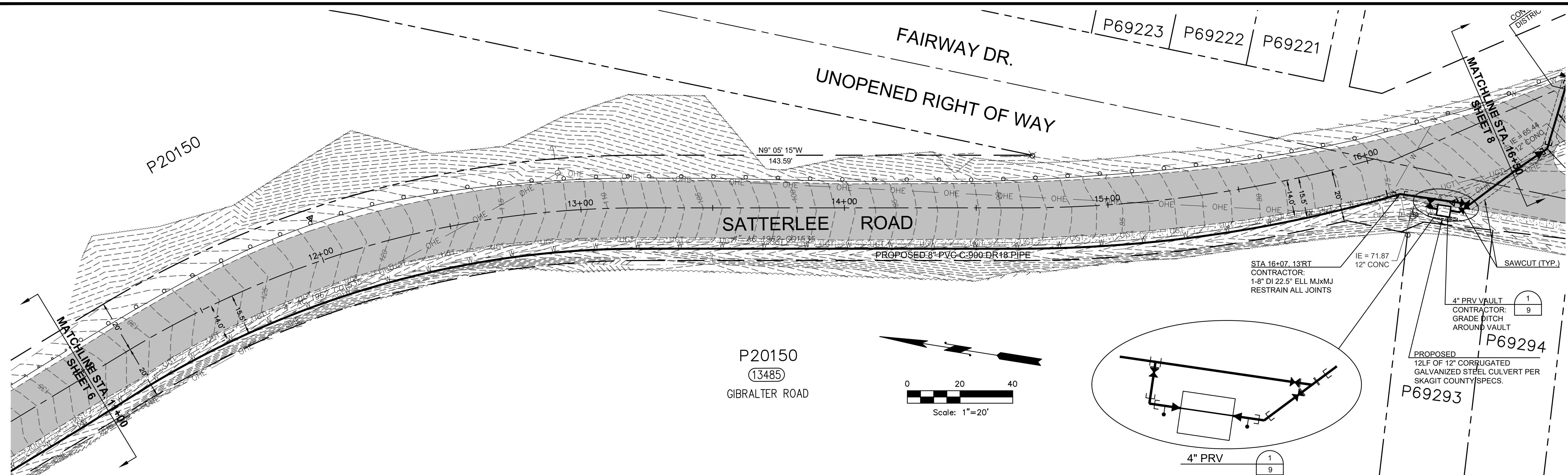

P20150  
(13485)  
GIBRALTER ROAD

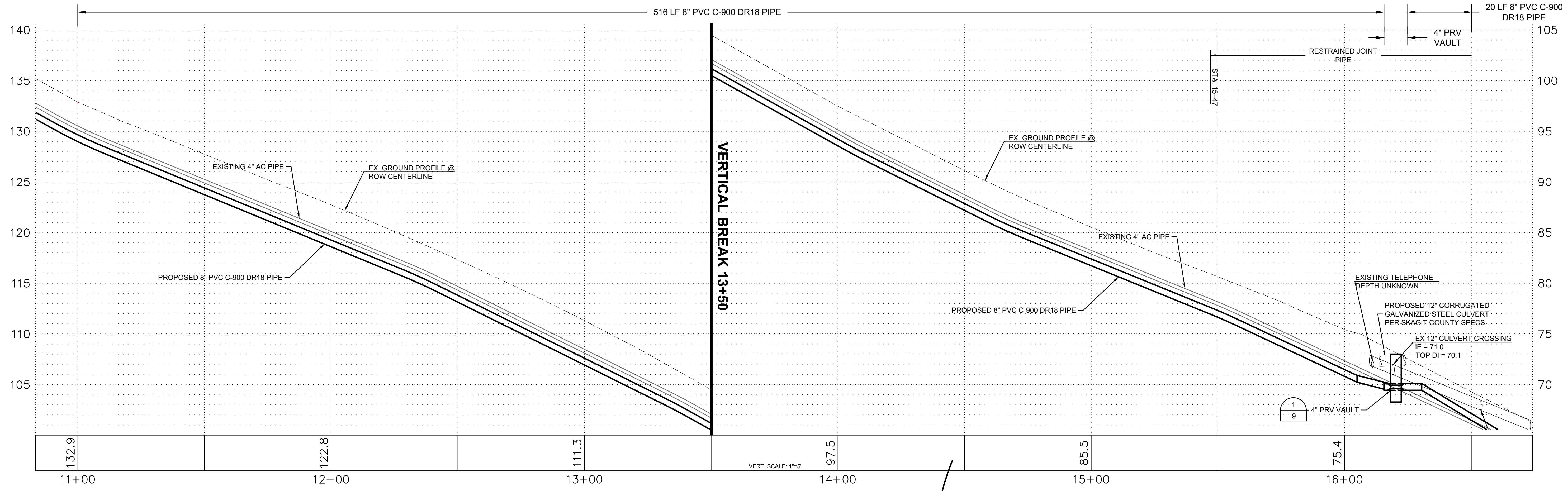
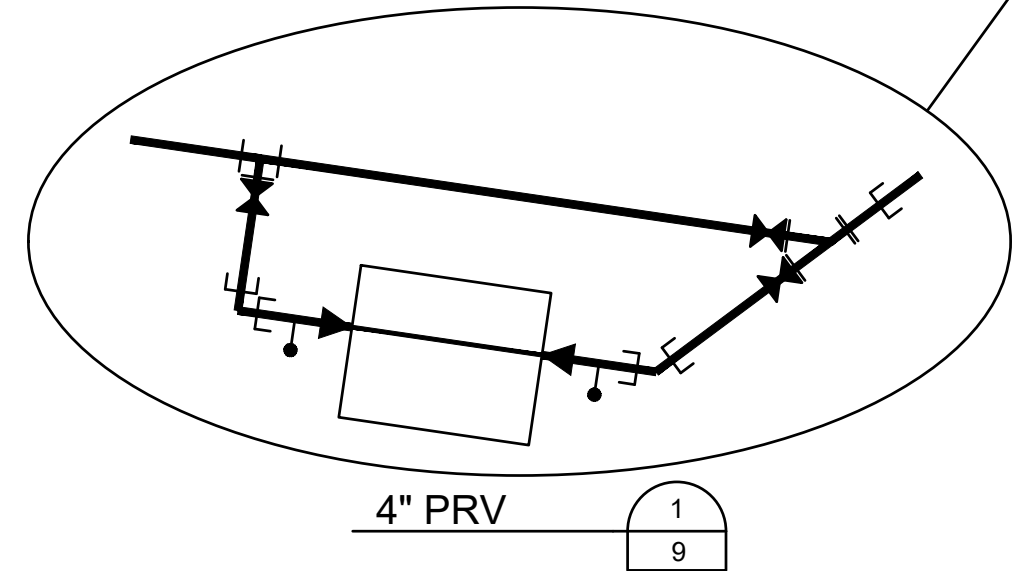
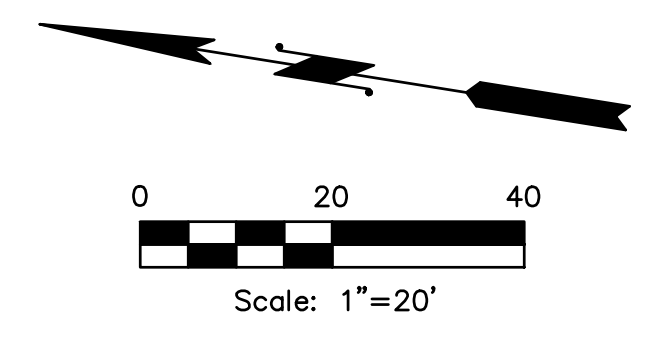

ISSUE	REVISIONS	BY	DATE
1.	ISSUED FOR BIDDING	GJS	11/19/14
2.	ISSUED FOR BIDDING	MCH	7/21/22

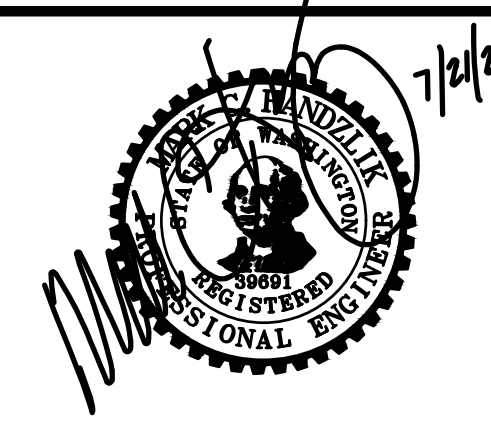
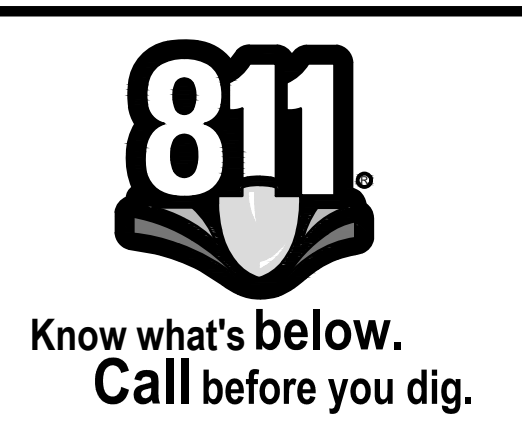

DATUM:  
HOR: ASSUMED  
VERT: NAVD 88

DSGN BY: MED  
DWN BY: MDO  
APPVD BY: MCH

CALL 48 HOURS BEFORE YOU DIG  
1-800-424-5555

DATE PRINTED: 7/28/22  
SEC: 8  
TWP: 34 N  
RGE: 2 E

**Skagit PUD**  
PUBLIC UTILITY DISTRICT

PUBLIC UTILITY DISTRICT NO. 1 of SKAGIT COUNTY  
1415 Freeway Drive  
Mount Vernon, WA 98273  
(360) 424-7104  
www.SkagitPud.org

SATTERLEE ROAD, GIBRALTER ROAD TO DRIVER ROAD  
PHASE I  
PLAN AND PROFILE 11+00 TO 16+50

SCALE: 1"=20'

P.N. 3505  
C.O. 4811

SHEET: 7 OF 11



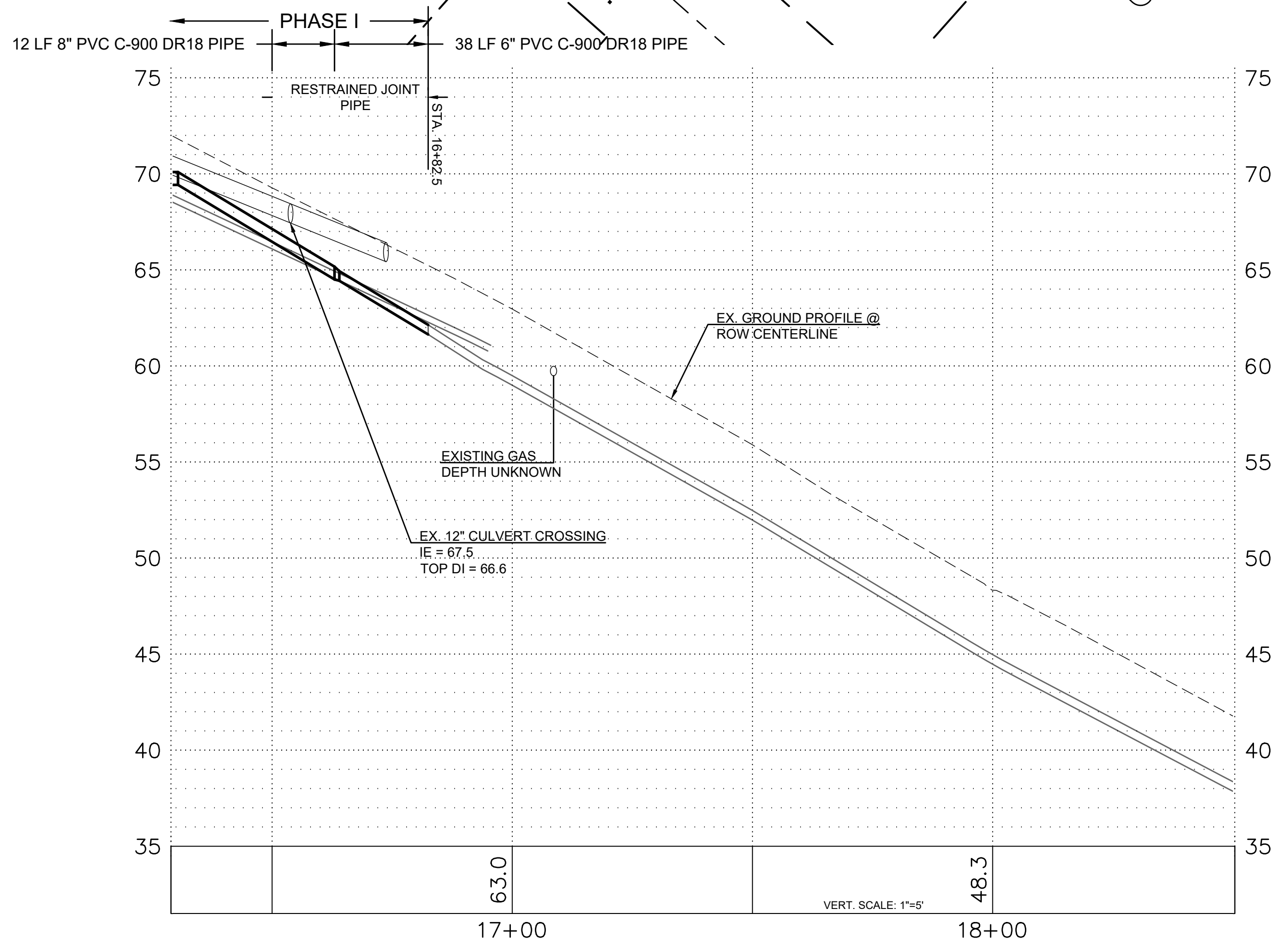
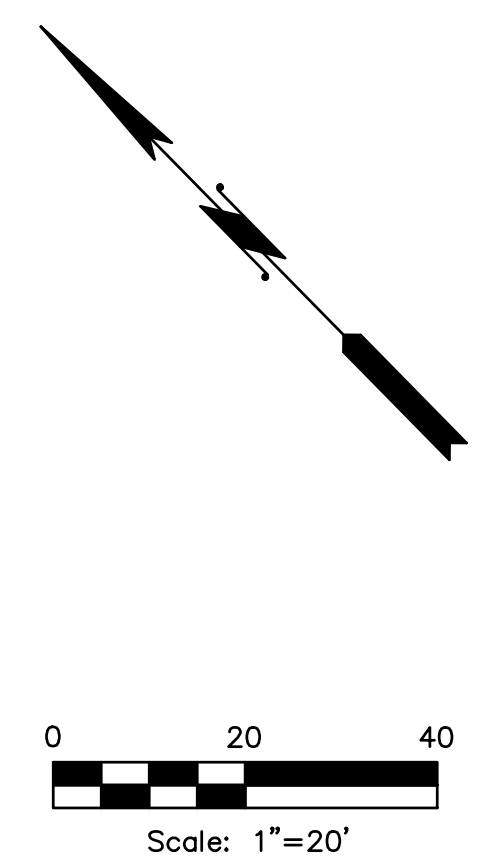
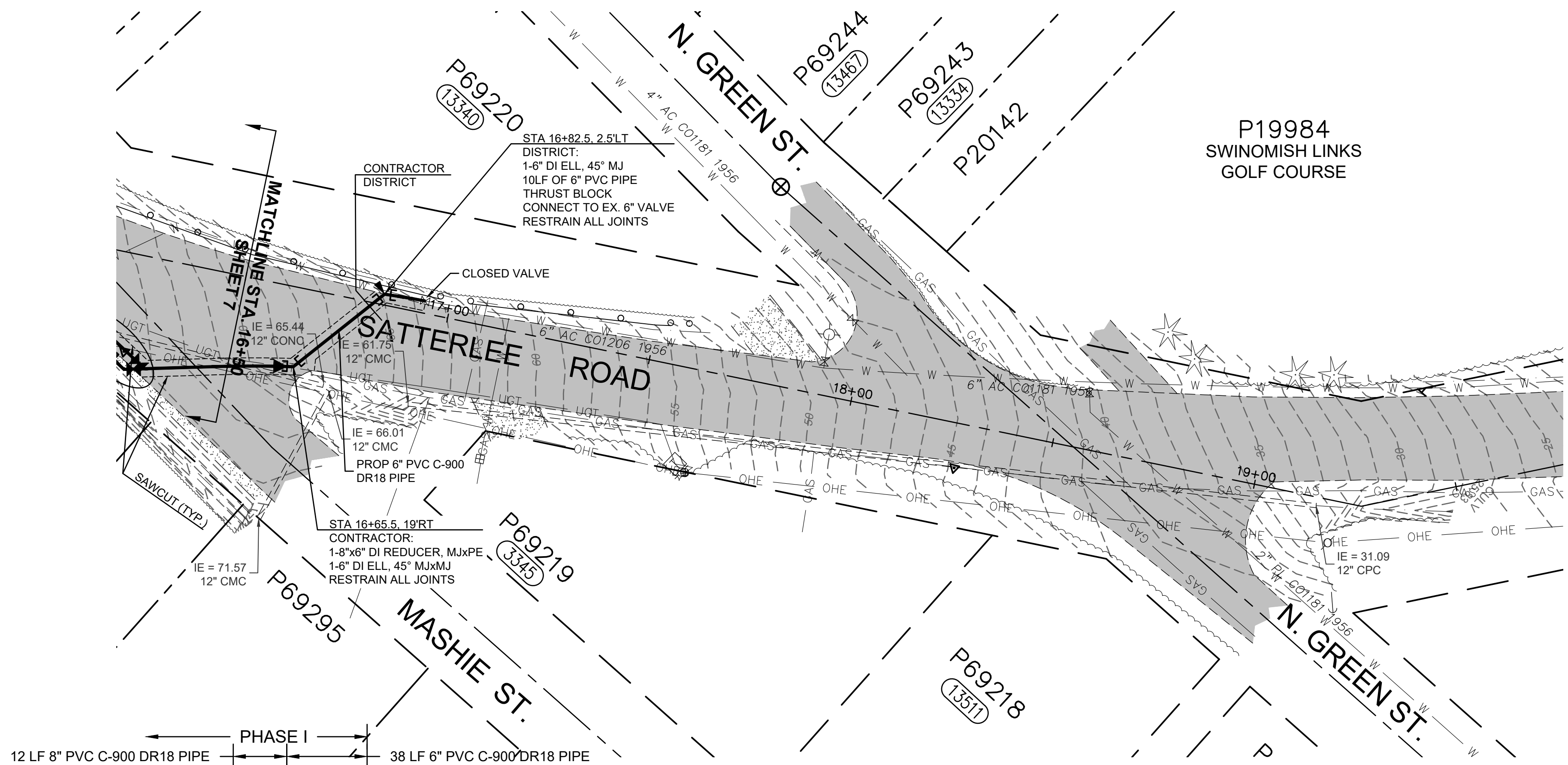

ISSUE	REVISIONS	BY	DATE
1.	ISSUED FOR BIDDING	GJS	11/19/14
2.	ISSUED FOR BIDDING	MCH	7/21/22

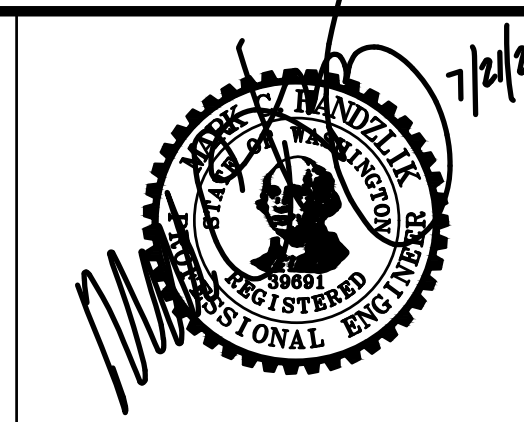
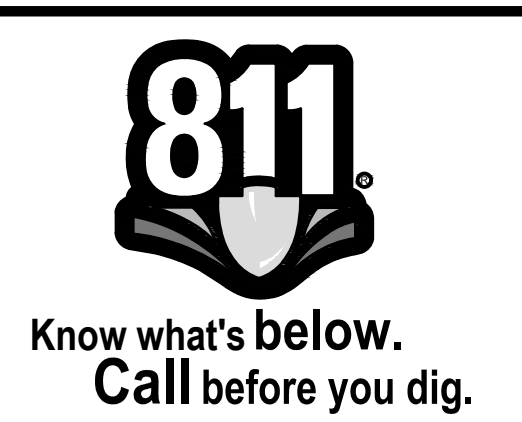

DATUM:  
 HOR: ASSUMED  
 VERT: NAVD 88  
 DSGN BY: MED  
 DWN BY: MDO  
 APPVD BY: MCH  
 CALL 48 HOURS BEFORE YOU DIG  
 1-800-424-5555  
 DATE PRINTED: 7/28/22  
 SEC: 8  
 TWP: 34 N  
 RGE: 2 E

**Skagit PUD**  
 PUBLIC UTILITY DISTRICT  
 NO. 1 of SKAGIT COUNTY  
 1415 Freeway Drive  
 Mount Vernon, WA 98273  
 (360) 424-7104  
 www.SkagitPud.org

SATTERLEE ROAD, GIBRALTER ROAD TO DRIVER ROAD  
 PHASE I  
 PLAN AND PROFILE 16+50 TO 19+48  
 SCALE: 1"=20'  
 P.N. 3505  
 C.O. 4811  
 SHEET: 8 OF 11

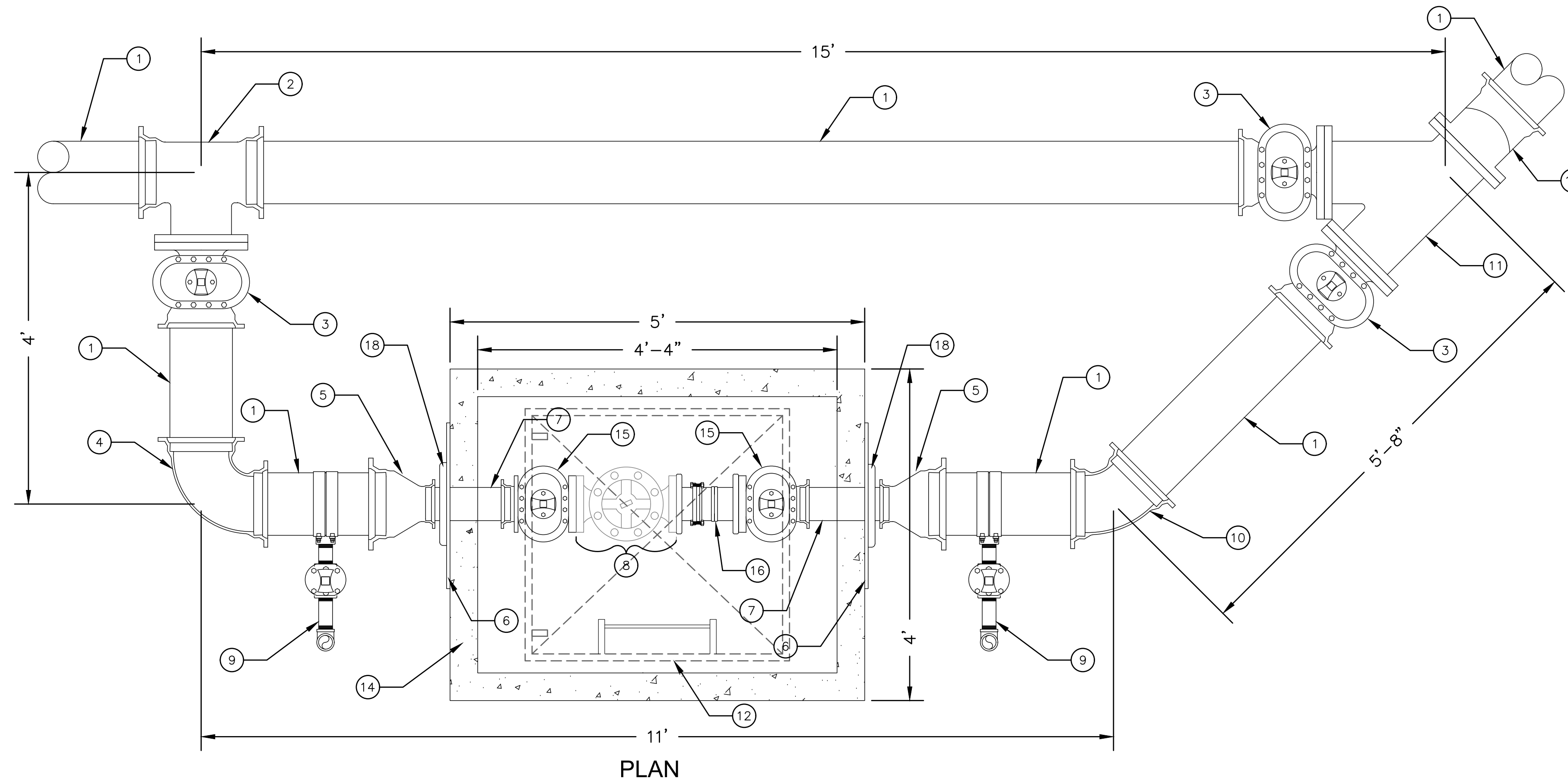

PLAN

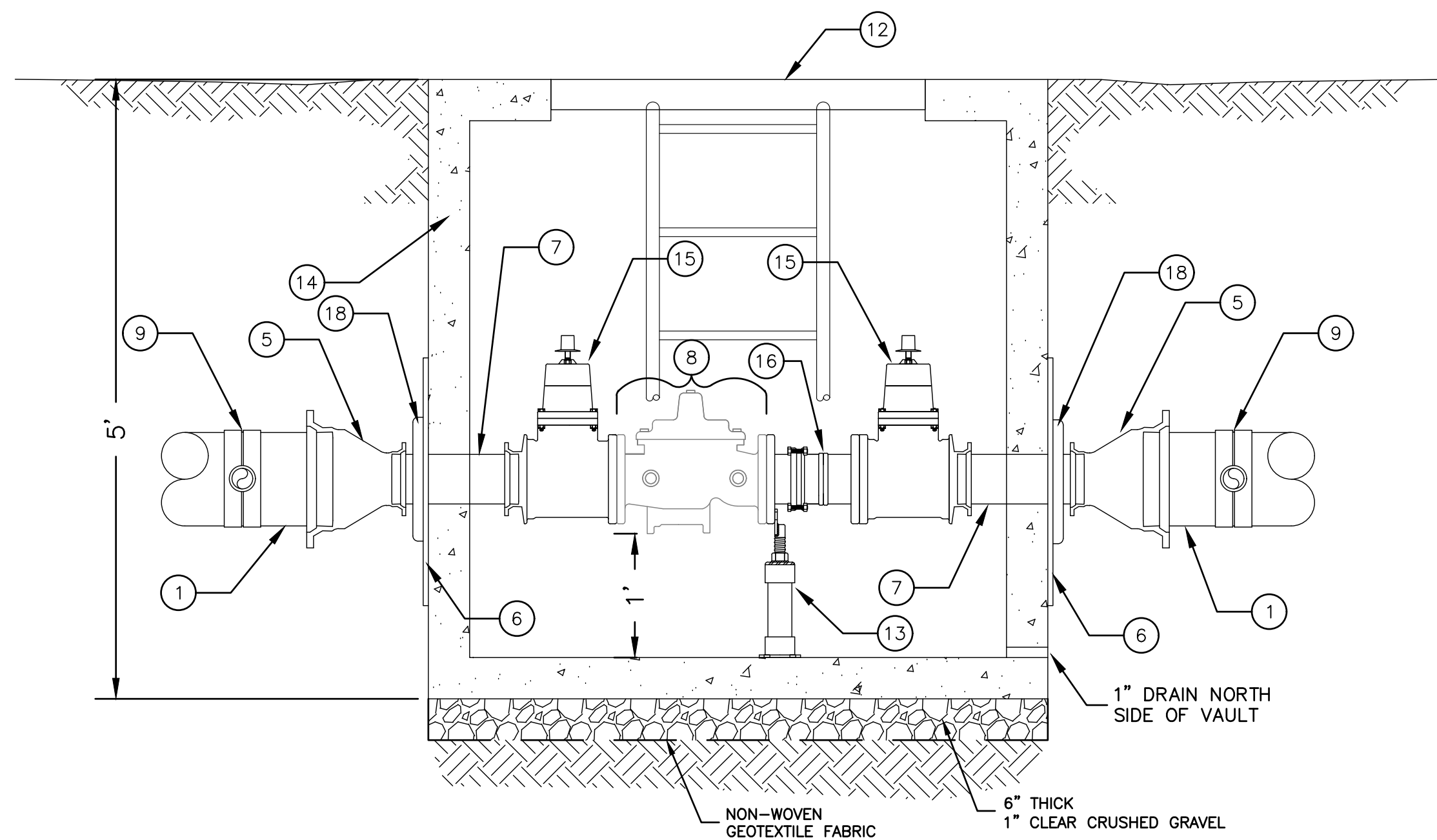

ELEVATION

4" PRV VAULT DETAIL  
SCALE : 1" = 1'

1  
7

BILL OF MATERIALS

QTY	NOMENCLATURE
1	8" C900 PVC DR18 PIPE
1	8" DI TEE, MJxFL
3	8" DI GATE VALVE, FLxMJ
1	8" DI 90° ELL, MJxMJ
2	8"x4" DI REDUCER, MJxMJ
2	2"x2"x1/2" STEEL PLATE, COAT W/ MASTIC
7	4" C900 PVC DR18 PIPE
8	4" PRV ASSEMBLY FROM PUD
9	2" DI FLUSHING ASSEMBLY PER PUD DETAIL WB2-1
10	8" DI 45° ELL, MJxMJ
11	8" DI WYE, FLxFL
12	1 SPRING ASSISTED ALUMINUM DIAMOND PLATE COVER W/ LOCKING HATCH
13	1 ADJUSTABLE SUPPORT
14	1 456-LA VAULT
15	2 4" DI GATE VALVE, MJxFL
16	1 4" DISMANTLING JOINT
17	1 8" DI 11.25° VERTICAL BEND, FLxMJ
18	2 RESTRAINING RINGS

NOTE: RESTRAIN ALL JOINTS

NO.	NOMENCLATURE	REQD.
1	WATER MAIN 8" C-300 PVC	1
2	CLAMP SERVICE DOUBLE STRAP X 2" (P.T., ALL BRASS, FORD #2085)	1
3	WIPER 2" X 4" BRASS	1
4	VALVE 2" CAST IRON RESILIENT WEDGE	1
5	PIPE 2" X 6" GALVANIZED	1
6	ELL 2" X 6" GALVANIZED	1
7	PIPE 2" GALVANIZED THREAD BOTH ENDS	1
8	CAP 2" PLASTIC THREADED	1
9	TRAFFIC RATED METER BOX AND LID (MD-STATES PLASTIC, INC. MSBC 1324-18 NOT FOR THROUGH-WAY TRAFFIC APPLICATION)	1
10	COVER 2" P.V.C. SEWER PIPE	1
11	VACANT	1
12	MARKER, BLUE, CARBONITE #30W-116	1
13	VACANT	1
14	VACANT	1
15	WIRE, #10 SOLID COPPER, BLUE COATED, EXTEND MIN. 18" INTO BOX, NEAR LID	1

OR EQUIVALENT APPROVED BY THE DISTRICT  
ALL BRASS FITTINGS TO BE LEAD FREE DOMESTIC BRASS PER UNITED STATES BILL S.3874.

NOTES:  
1. PLASTIC THREADED CAP (18) TO BE HAND TIGHT ONLY.

ISSUE	REVISIONS	BY	DATE
1.	ISSUED FOR BIDDING	GJS	11/19/14
2.	ISSUED FOR BIDDING	MCH	7/21/22



DATUM:  
HOR: ASSUMED  
VERT: NAVD 88

DSGN BY: MED  
DWN BY: MDO  
APPVD BY: MCH

CALL 48 HOURS BEFORE YOU DIG  
1-800-424-5555

DATE PRINTED: 7/28/22  
SEC: 8  
TWP: 34 N  
RGE: 2 E

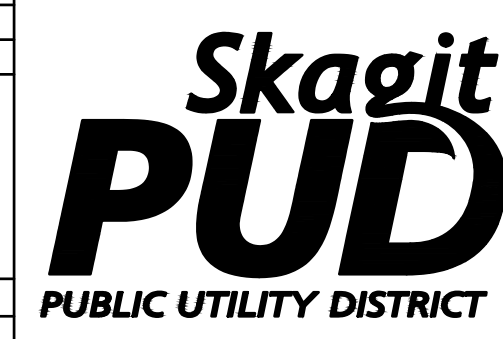

PUBLIC UTILITY DISTRICT  
NO. 1 of SKAGIT COUNTY  
1415 Freeway Drive  
Mount Vernon, WA 98273  
(360) 424-7104  
www.SkagitPud.org

SATTERLEE ROAD, GIBRALTER ROAD TO DRIVER ROAD  
PHASE I  
4" PRV DETAIL



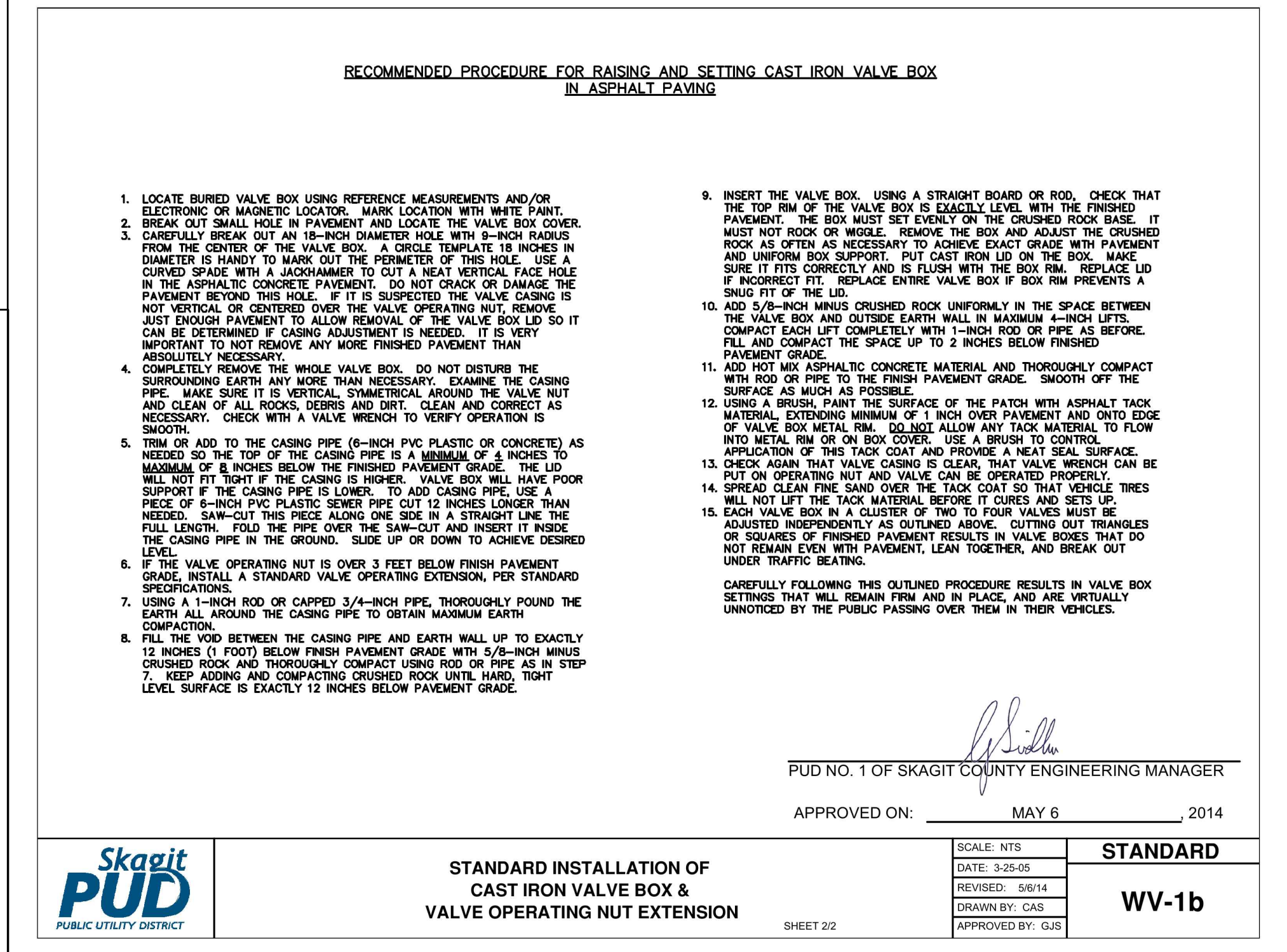
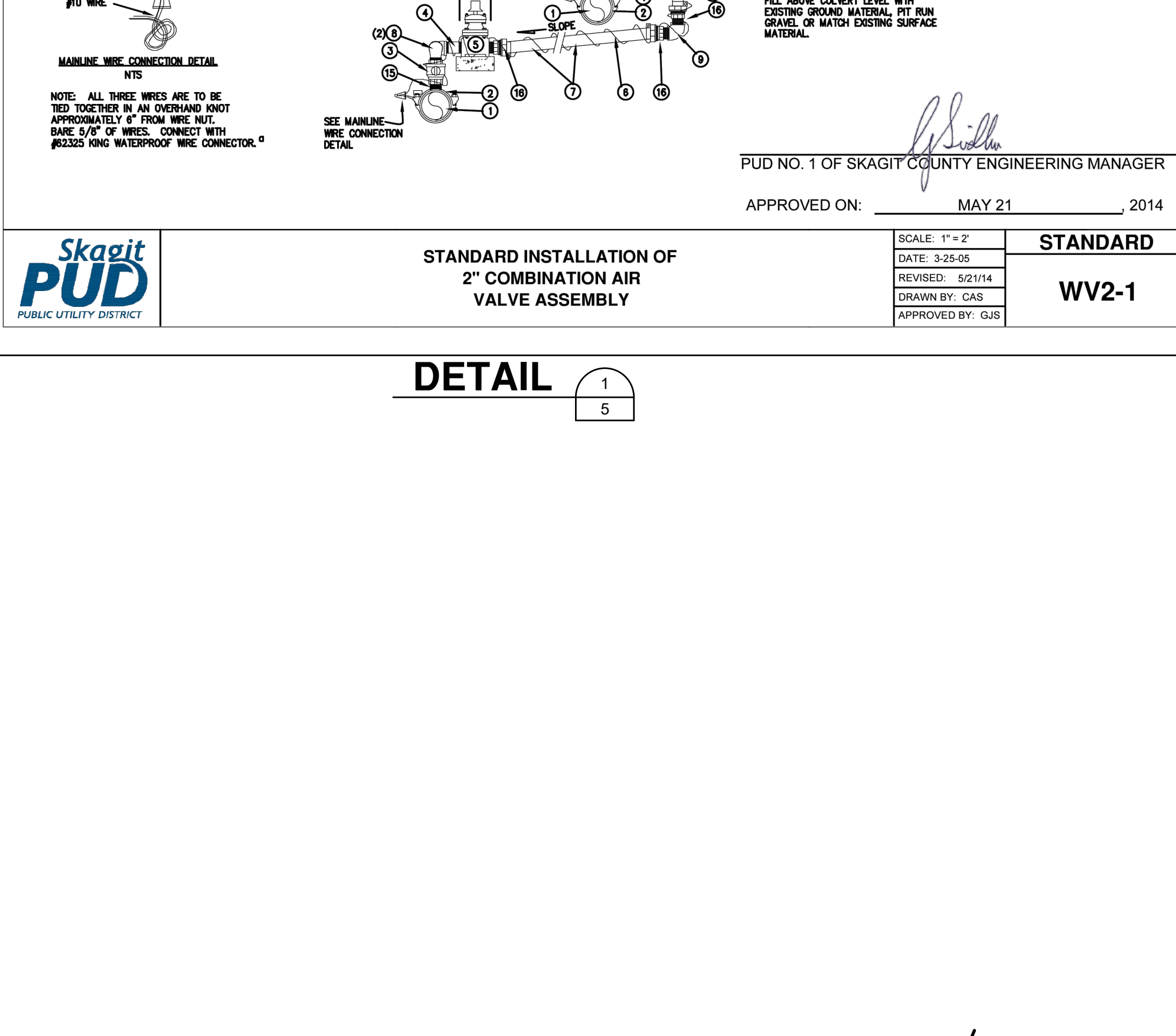
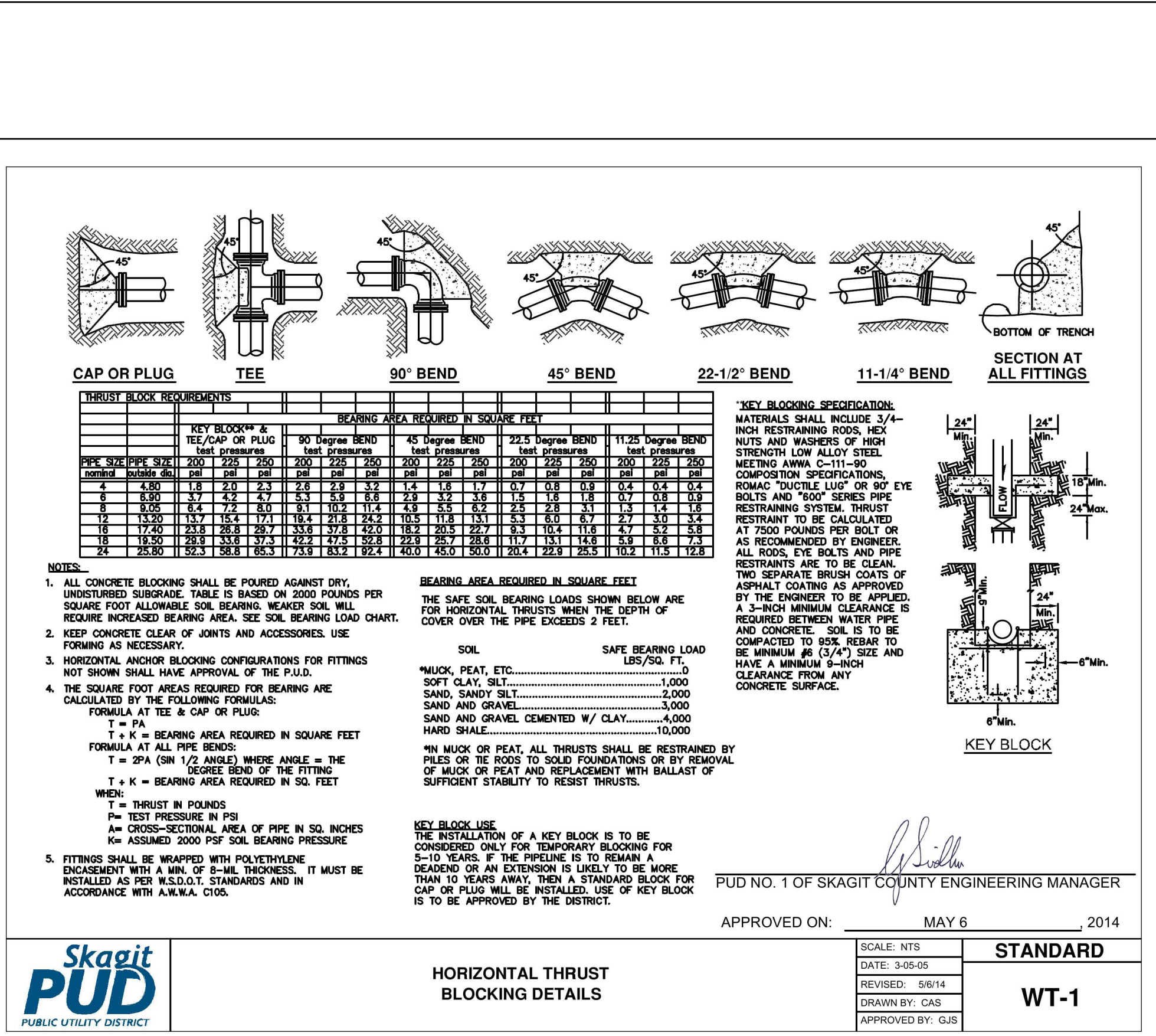
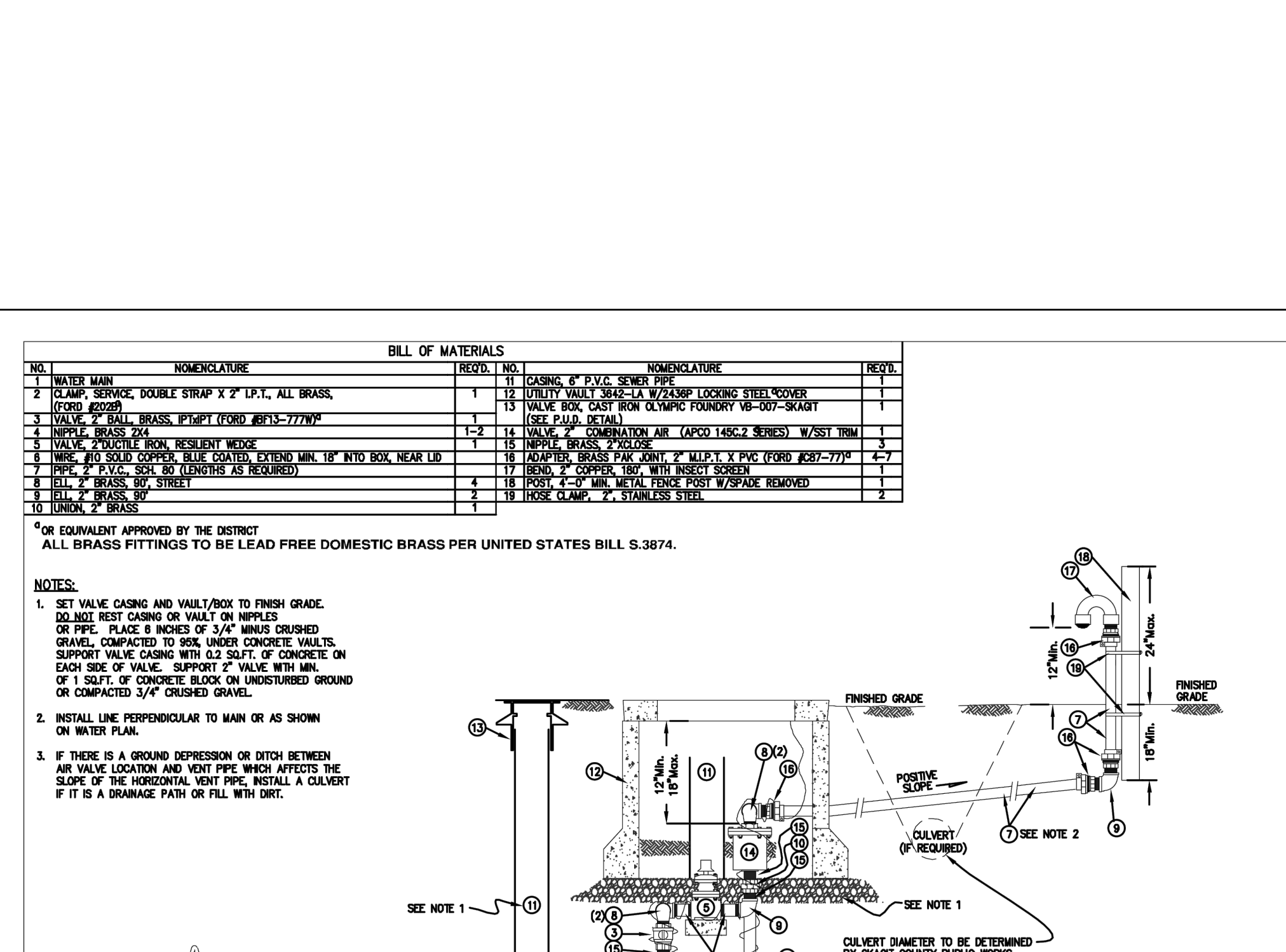
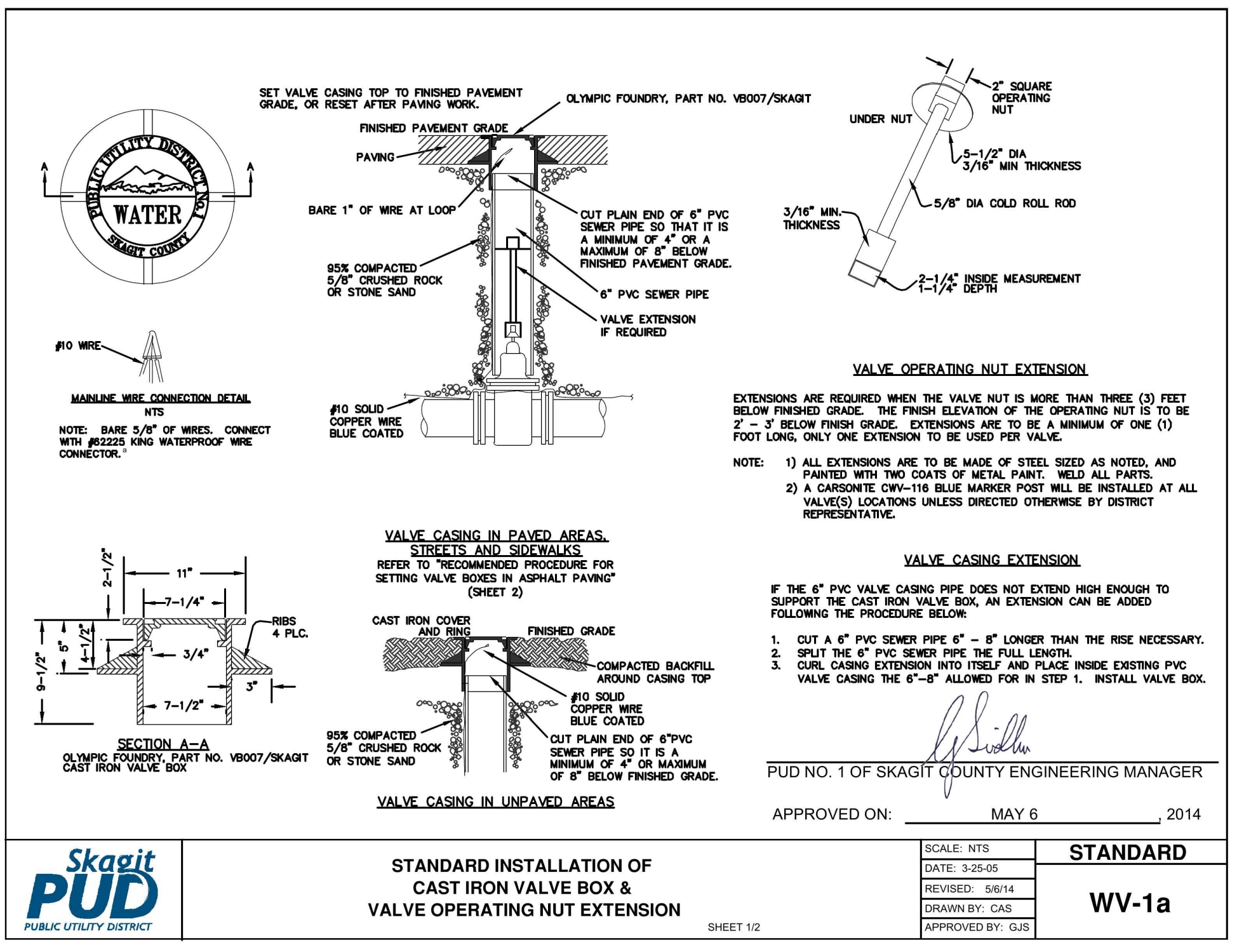

ISSUE	REVISIONS	BY	DATE
1.	ISSUED FOR BIDDING	GJS	11/19/14
2.	ISSUED FOR BIDDING	MCH	7/21/22

**811**  
Know what's below.  
Call before you dig.

**Skagit PUD**  
PUBLIC UTILITY DISTRICT

CALL 48 HOURS BEFORE YOU DIG  
1-800-424-5555

DATE PRINTED: 7/28/22  
SEC: 8  
TWP: 34 N  
RGE: 2 E

DATUM: HOR: ASSUMED  
VERT: NAVD 88

DSGN BY: MED  
DWN BY: MDO  
APPV BY: MCH

**Skagit PUD**  
PUBLIC UTILITY DISTRICT

1415 Freeway Drive  
Mount Vernon, WA 98273  
(360) 424-7104  
www.SkagitPud.org

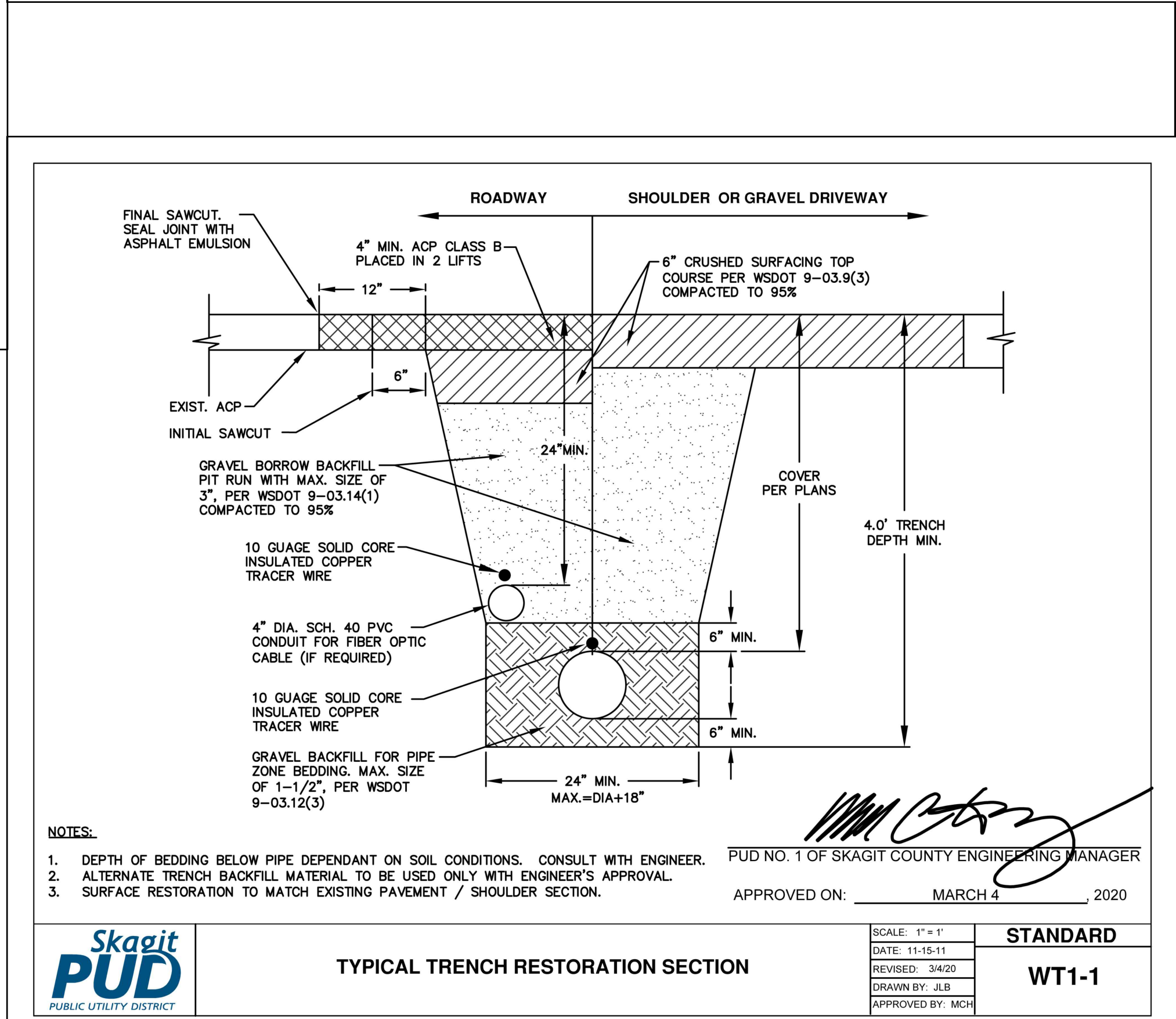

**Skagit PUD**  
PUBLIC UTILITY DISTRICT

SATTERLEE ROAD, GIBRALTER ROAD TO DRIVER ROAD  
PHASE I  
STANDARD DETAILS

SCALE: NONE

P.N. 3505  
C.O. 4811

SHEET: 10 OF 11



